

# **Wood-Mizer®**

## **Replacement Parts**

---

**LX100**

**rev. A3.02**

---



**Safety is our #1 concern!** Read and understand all safety information and instructions before operating, setting up or maintaining this machine.

*Form #802*

# Table of Contents

# Section-Page

<b>SECTION 1</b>	<b>GENERAL INFORMATION</b>	<b>1-1</b>
1.1	How To Use the Parts List.....	1-1
1.2	Sample Assembly .....	1-1
<b>SECTION 2</b>	<b>BED FRAME PARTS</b>	<b>2-1</b>
2.1	Bed Frame Segment .....	2-1
2.2	Bed Frame Extension .....	2-3
2.3	Bed Frame M Segment .....	2-4
2.4	Bed Frame S Segment .....	2-5
2.5	Bumpers .....	2-6
2.6	Bumpers .....	2-7
2.7	Bed Foot .....	2-8
2.8	Retrofit Assembly, LX100 Side Support Angle Setting .....	2-9
2.9	Cross Rail Cover Set (Option) .....	2-10
2.10	Additional Cross Bars w/Covers & Side Support Rollers (Option) ..	2-11
2.11	Additional Cross Bar w/Cover (Option) .....	2-12
2.12	Side Support Roller (Option) .....	2-13
<b>SECTION 3</b>	<b>BLADE GUIDE ROLLERS &amp; ARM</b>	<b>3-1</b>
3.1	Blade Guide Assembly, Idle Side .....	3-1
3.2	Blade Guide Assembly, Drive Side .....	3-2
3.3	Blade Guide Roller Guard .....	3-3
3.4	Blade Guide Arm Assembly, E15 .....	3-4
3.5	Blade Guide Arm w/Drive .....	3-6
3.6	Blade Guide Arm Drive .....	3-8
<b>SECTION 4</b>	<b>BLADE WHEELS &amp; TENSIONER</b>	<b>4-1</b>
4.1	Blade Wheel Assembly, Drive Side (E15) .....	4-1
4.2	Blade Wheel Assembly, Drive Side - E10 .....	4-2
4.3	Blade Wheel Assembly, Idle Side .....	4-3
4.4	Blade Tensioner Assembly .....	4-5
<b>SECTION 5</b>	<b>SAW HEAD</b>	<b>5-1</b>
5.1	Blade Housing Cover .....	5-1
5.2	Water Lube Assembly .....	5-3
5.3	Slide Pads .....	5-5
5.4	Saw Head Decals .....	5-7
5.5	Belt Tensioner/Brake Assembly .....	5-8
5.6	Belt Tension Roller/Brake .....	5-10
5.7	Drive Belt Tension Roller .....	5-11

# Table of Contents

# Section-Page

<b>SECTION 6</b>	<b>SAWMILL MAST</b>	<b>6-1</b>
6.1	EH10S, Mast and Up/Down Limit Switches .....	6-1
6.2	Handle for Manual Feed .....	6-4
6.3	E15 Sawmill Mast (African Version) .....	6-5
6.4	EC Mast .....	6-8
<b>SECTION 7</b>	<b>POWER FEED SYSTEM</b>	<b>7-1</b>
7.1	AC Power Feed Assembly .....	7-1
7.2	Power Feed Guard Assembly .....	7-3
7.3	Power Feed 597521 .....	7-4
7.4	Power Feed Assembly 597521-7 .....	7-5
<b>SECTION 8</b>	<b>UP/DOWN SYSTEM</b>	<b>8-1</b>
8.1	Up/Down Drive Assembly .....	8-1
8.2	Blade Height Scale Assembly .....	8-2
8.3	Up/Down Sprockets .....	8-4
<b>SECTION 9</b>	<b>MOTOR ASSEMBLY</b>	<b>9-1</b>
9.1	E10/E15 Motor Kit .....	9-1
9.2	E10S/E15S Motor Kit .....	9-3
9.3	Electrical Box .....	9-5
9.4	Control Box, LX100 AC .....	9-6
9.5	Control Box, LX100 AC (version without CE marking) .....	9-8
9.6	Blade Lube Kit .....	9-10
9.7	Limit Switch Assembly .....	9-11

## SECTION 1 GENERAL INFORMATION

### 1.1 How To Use the Parts List

- Use the index above to locate the assembly that contains the part you need.
- Go to the appropriate section and locate the part in the illustration.
- Use the number pointing to the part to locate the correct part number and description in the table.
- Parts shown indented under another part are included with that part.
- Parts marked with a diamond (◆) are only available in the assembly listed above the part.

See the sample table below. Sample Part #A01111 includes part F02222-2 and subassembly A03333. Subassembly A03333 includes part S04444-4 and subassembly K05555. The diamond (◆) indicates that S04444-4 is not available except in subassembly A03333. Subassembly K05555 includes parts M06666 and F07777-77. The diamond (◆) indicates M06666 is not available except in subassembly K05555.

1.2 Sample Assembly				
REF.	DESCRIPTION (◆ Indicates Parts Available In Assemblies Only)	PART #	QTY	
	Sample Assembly, Complete (Includes All Indented Parts Below)	A01111	1	
1	Sample Part	F02222-22	1	
	Sample Subassembly (Includes All Indented Parts Below)	A03333	1	
2	Sample Part (◆ Indicates Part Is Only Available With A03333)	S04444-4	1	◆
	Sample Subassembly (Includes All Indented Parts Below)	K05555	1	
3	Sample Part (◆ Indicates Part Is Only Available With K05555)	M06666	2	◆
4	Sample Part	F07777-77	1	

#### To Order Parts:

- From Europe call our European Headquarters and Manufacturing Facility in Kolo, Poland at **+48-63-2626000**. From the continental U.S., call our toll-free Parts hotline at **1-800-525-8100**. Have your customer number, vehicle identification number, and part numbers ready when you call. From other international locations, contact the Wood-Mizer distributor in your area for parts.

#### Office Hours:

Country	Monday - Friday	Saturday	Sunday
Poland	7-15	Closed	Closed
US	8 a.m.- 5 p.m.	8 a.m.- 12 p.m.	Closed



**CAUTION!** It is strongly recommended that only original spare parts be used.



## SECTION 2 BED FRAME PARTS

### 2.1 Bed Frame Segment

LX\_004.d  
 LX150S3EH15S-P\_Manual

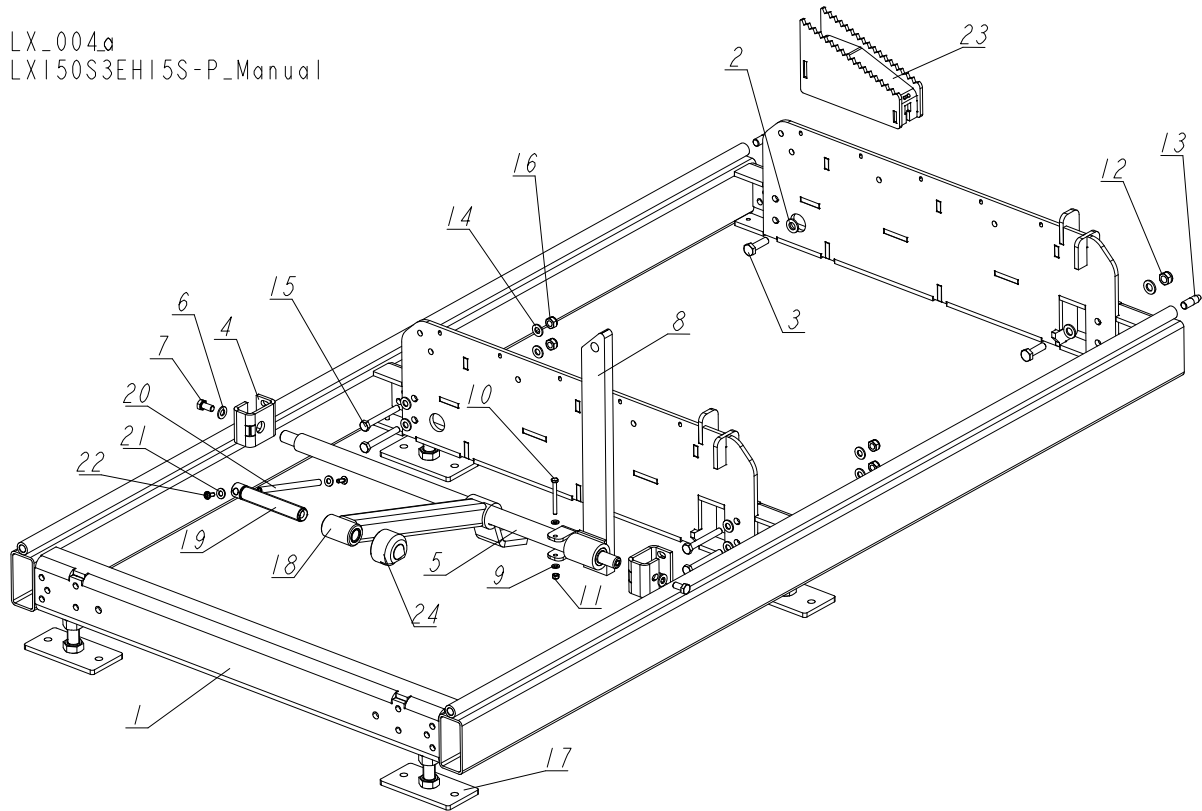

REF.	DESCRIPTION (◆ indicates parts available in assemblies only)	PART #	QTY
	<b>SEGMENT, S - COMPLETE</b>	<b>516516</b>	<b>1/0</b>
	<b>SEGMENT, M - COMPLETE</b>	<b>516513</b>	<b>0/1</b>
1	SEGMENT WELDMENT, S (3 CROSS RAILS)	516261-1	1/0
	SEGMENT WELDMENT, M (4 CROSS RAILS)	516250-1	0/1
2	WASHER, 13 FLAT ZINC	F81056-1	4
3	BOLT, M12X40-8.8 HEX HEAD FULL THREAD ZINC	F81004-4	2
	<b>SIDE SUPPORT ASSEMBLY</b>	<b>517242</b>	<b>1</b>
4	BRACKET, LOG CLAMP MOUNTING	500338-1	2
5	ROD, LOG CLAMP MAIN	515059-1	1
6	WASHER, 10.5 FLAT ZINC	F81055-1	2
7	BOLT, M10X20-5.8 HEX HEAD FULL THREAD ZINC	F81003-1	2
	<b>SUPPORT, SIDE - COMPLETE</b>	<b>517721</b>	<b>1</b>
8	SUPPORT WELDMENT, SIDE	517722-1	1
9	WASHER, 6.4 FLAT ZINC	F81053-1	2
10	BOLT, M6X60-8.8 HEX HEAD FULL THREAD ZINC	F81001-9	1
11	NUT, M6-8-B HEX NYLON ZINC LOCK	F81031-2	1
12	NUT, M12 8 HEX NYLON ZINC LOCK	F81034-2	2
13	PIN, SPECIAL	090675	2
14	WASHER, 10.5 FLAT ZINC	F81055-1	8

## 2

**BED FRAME PARTS***Bed Frame Segment*

REF.	DESCRIPTION (◆ indicates parts available in assemblies only)	PART #	QTY	
15	BOLT, M10X80-8.8 HEX HEAD ZINC	F81003-50	4	
16	NUT, M10-8-B HEX NYLON ZINC LOCK	F81033-1	4	
17	FOOT, LT15 BED - COMPLETE <a href="#">See Section 2.7</a>	514997	4/6	
18	ARM, LOG CLAMP	521465-1	1/2	
	<b>STUD W/ROD, LOG CLAMP - COMPLETE</b>	<b>507563</b>	<b>1/2</b>	
19	STUD, LOG CLAMP	507463	1	
	<b>COMPLETE ROD</b>	<b>511924</b>	<b>1</b>	
20	ROD, ZINC-PLATED	511923-1	1	
21	WASHER, 8.4 FLAT ZINC	F81054-1	2	
22	SCREW, M6X16 BN 11252 "BOSSARD".	F81001-24	2	
23	WEDGE, LT15 BED	515413-1	1	
24	CAP, MOUNTING, CLAMP	T00414	1	

**2.2 Bed Frame Extension**

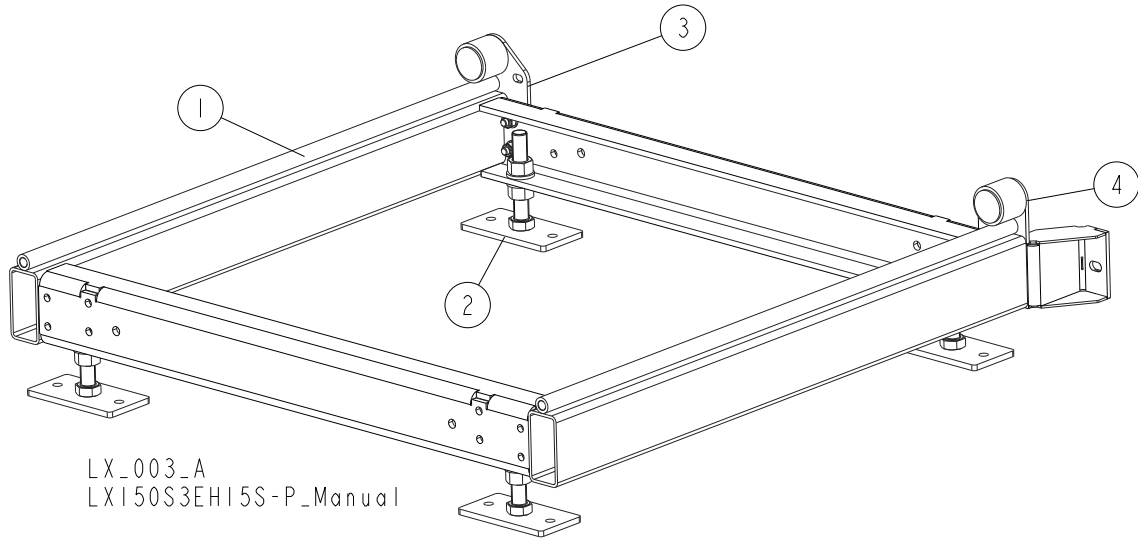

REF.	DESCRIPTION (◆ indicates parts available in assemblies only)	PART #	QTY
	<b>EXTENSION, BED FRAME - COMPLETE</b>	<b>516525</b>	<b>1</b>
<b>1</b>	EXTENSION, BED FRAME	516268-1	1
<b>2</b>	FOOT, LT15 BED - COMPLETE	514997	4
<b>3</b>	BUMPER, LT15 RIGHT - COMPLETE <a href="#">See Section 2.5</a>	515062	1
<b>4</b>	BUMPER, LT15 LEFT - COMPLETE <a href="#">See Section 2.6</a>	517896	1

## 2 BED FRAME PARTS

### Bed Frame M Segment

### 2.3 Bed Frame M Segment

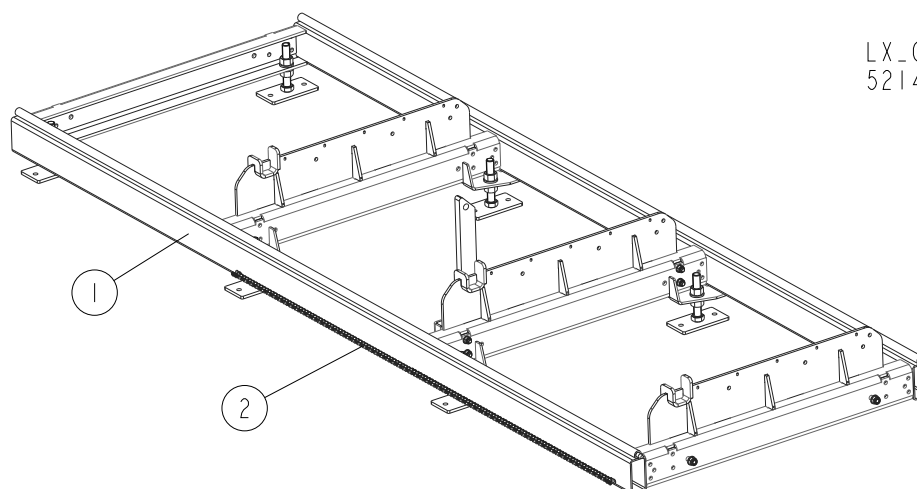

LX\_046  
521434\_Manual

REF.	DESCRIPTION (◆ indicates parts available in assemblies only)	PART #	QTY	
	BED SEGMENT, LX100 M WITH POWER FEED	<b>521434</b>	<b>1</b>	
<b>1</b>	SEGMENT M complete LX100	<b>516513</b>	1	
<b>2</b>	CHAIN 08B; LENGTH.=2,78M (219 LINKS)	<b>521433</b>	1	

**2.4 Bed Frame S Segment**

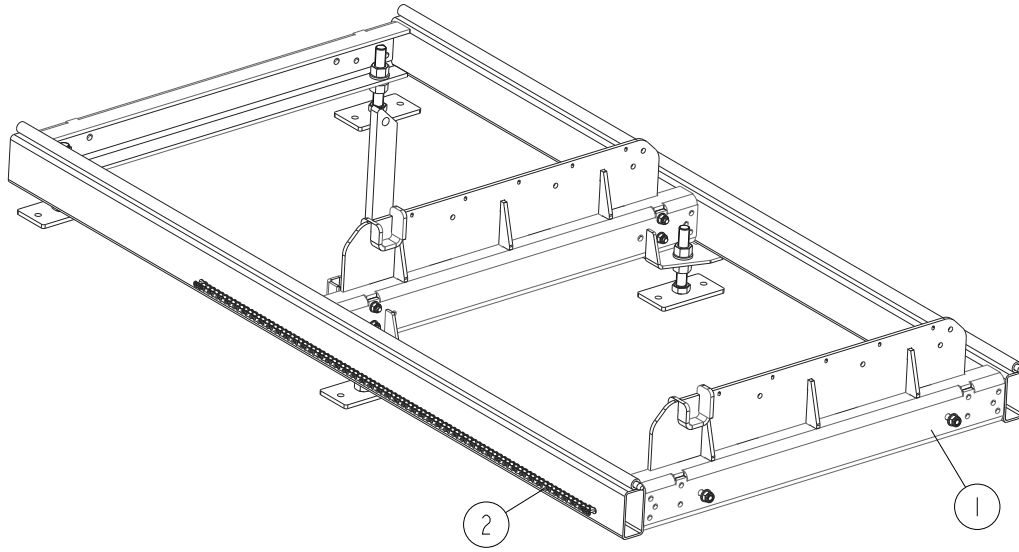

REF.	DESCRIPTION (◆ indicates parts available in assemblies only)	PART #	QTY
	BED SEGMENT, LX100 S WITH POWER FEED	<b>521432</b>	<b>1</b>
<b>1</b>	SEGMENT S, COMPLETE LX100	<b>516516</b>	<b>1</b>
<b>2</b>	CHAIN 08B; LENGTH.=1,87M (147 LINKS)	<b>521431</b>	<b>1</b>

## 2 BED FRAME PARTS

### Bumpers

### 2.5 Bumpers

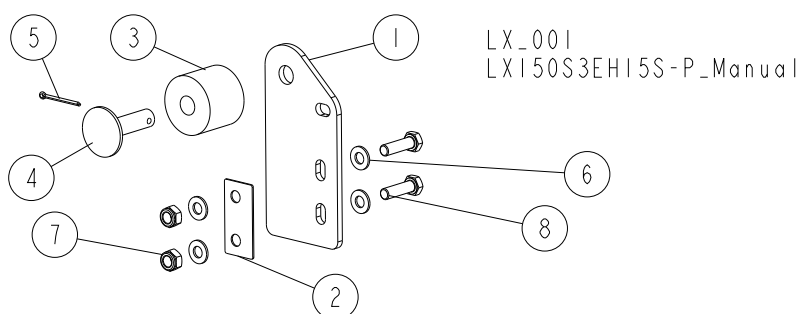

REF.	DESCRIPTION (◆ indicates parts available in assemblies only)	PART #	QTY
	<b>BUMPER, LT15 RIGHT - COMPLETE</b>	<b>515062</b>	<b>1</b>
	<b>BUMPER, LT15 LEFT - COMPLETE</b>	<b>515063</b>	<b>1</b>
1	PLATE, BUMPER	516075-1	1
2	WASHER, BUMPER PLATE SPACER	515061	1
3	BUSHING, 11/16X2 1/8X1 3/4 RUBBER	P12165	1
4	MOUNT WELDMENT, CARRIAGE STOP	086182-1	1
5	PIN, S-ZN 4X25 COTTER	F81043-2	1
6	WASHER, 10.5 FLAT ZINC	F81055-1	4
7	NUT, M10-8-B HEX NYLON ZINC LOCK	F81033-1	2
8	BOLT, M10X35 8.8 HEX HEAD FULL THREAD ZINC	F81003-17	2

**2.6 Bumpers**

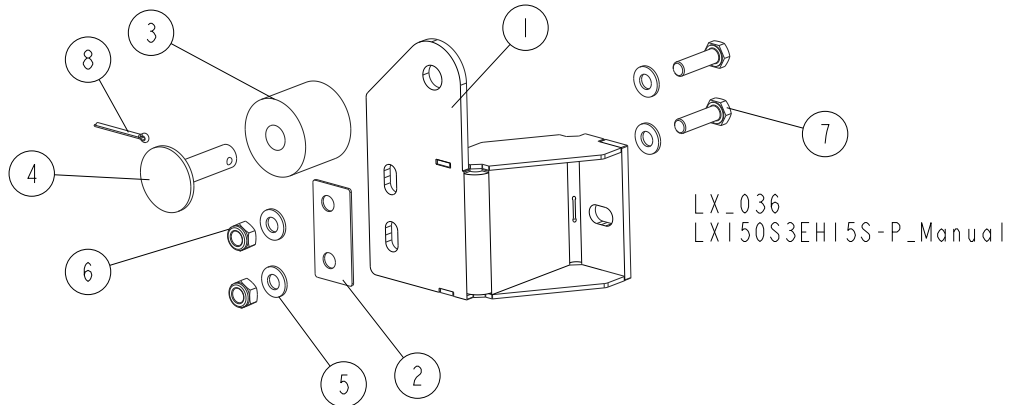

REF.	DESCRIPTION (◆ indicates parts available in assemblies only)	PART #	QTY	
	<b>BUMPER, RIGHT - COMPLETE</b>	<b>517897</b>	<b>1/0</b>	
	<b>BUMPER, LEFT - COMPLETE</b>	<b>517896</b>	<b>0/1</b>	
<b>1</b>	BRACKET WELDMENT, RIGHT	517902-1	1/0	
	BRACKET WELDMENT, LEFT	517901-1	0/1	
<b>2</b>	WASHER, BUMPER PLATE SPACER	515061-1	1	
<b>3</b>	BUSHING, 11/16X2 1/8X1 3/4 RUBBER	P12165	1	
<b>4</b>	MOUNT WELDMENT, CARRIAGE STOP	086182-1	1	
<b>5</b>	WASHER, 10.5 FLAT ZINC	F81055-1	4	
<b>6</b>	NUT, M10-8-B HEX NYLON ZINC LOCK	F81033-1	2	
<b>7</b>	BOLT, M10X35 8.8 HEX HEAD FULL THREAD ZINC	F81003-17	2	
<b>8</b>	PIN, S-ZN 4X25 COTTER	F81043-2	1	

# 2 BED FRAME PARTS

## Bed Foot

### 2.7 Bed Foot

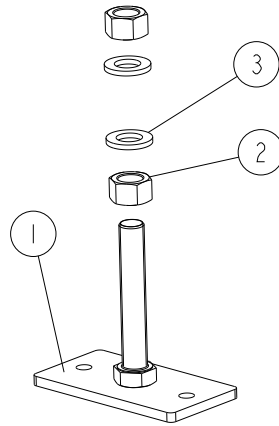

LX\_002  
LXI50S3EHI5S-P\_Manual

REF.	DESCRIPTION (◆ indicates parts available in assemblies only)	PART #	QTY
	<b>FOOT, LT15 BED - COMPLETE</b>	<b>514997</b>	<b>1</b>
1	FOOT WELDMENT, LT15 BED	514996-1	1
2	NUT, M20-8 HEX ZINC	F81037-1	2
3	WASHER, 21 FLAT ZINC	F81059-2	2



**2.8 Retrofit Assembly, LX100 Side Support Angle Setting**

538683\_001  
538683\_MANUAL

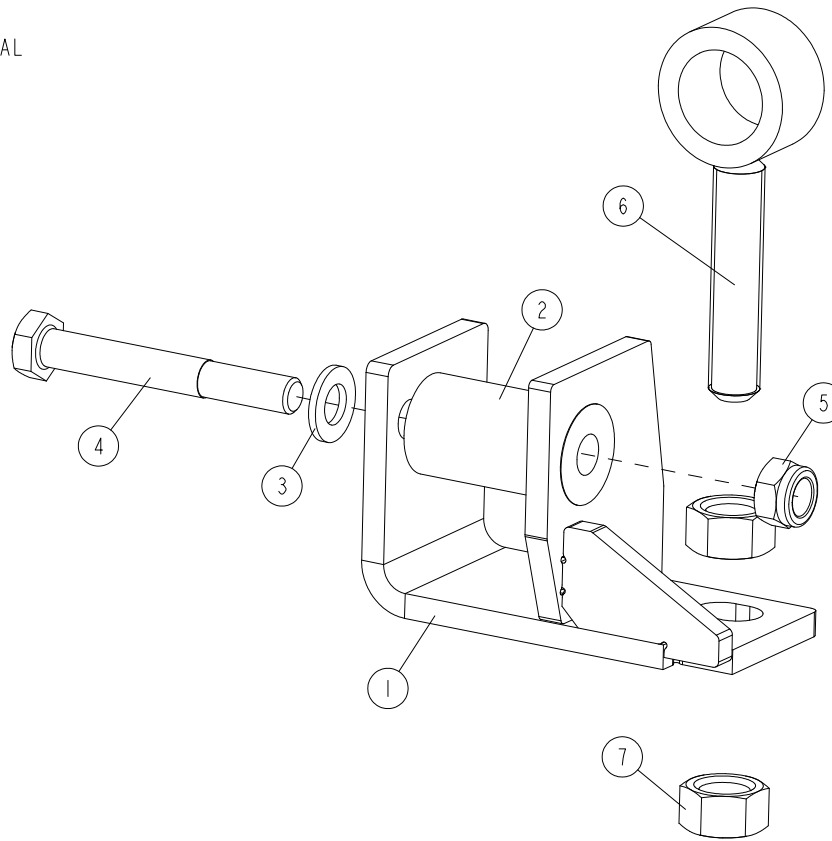

REF.	DESCRIPTION (◆ indicates parts available in assemblies only)	PART #	QTY
-	<b>RETROFIT ASSEMBLY, LX100 SIDE SUPPORT ANGLE SETTING</b>	538683	1
1	BRACKET WELDMENT	538682-1	1
2	BUSHING, 13/32 - 57	538681-1	1
3	WASHER, 13 FLAT ZINC	F81056-1	1
4	BOLT, M12X90 8.8 HEX HEAD ZINC	F81004-2	1
5	NUT, M12-8 DIN 982 HEX NYLON ZINC LOCK	F81034-2	1
6	ROD WELDMENT, SIDE SUPPORT POSITIONER	538677-1	1
7	NUT, M16 5.8 HEX	F81036-5	2

## 2 BED FRAME PARTS

### Cross Rail Cover Set (Option)

## 2.9 Cross Rail Cover Set (Option)

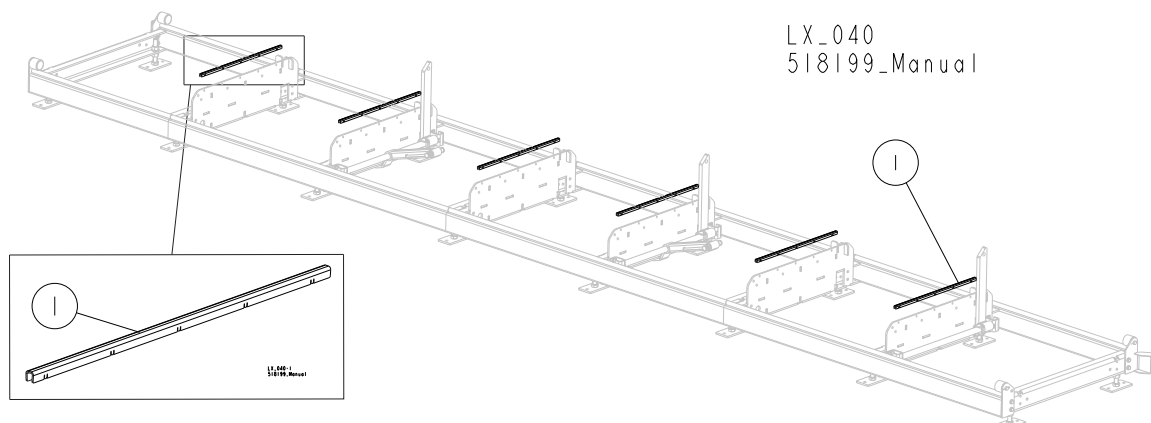

REF.	DESCRIPTION (◆ indicates parts available in assemblies only)	PART #	QTY	
	COVER SET, BED CROSS RAIL (FOR LX100 S2 FRAME)	518199-S2	1/-/-	
	COVER SET, BED CROSS RAIL (FOR LX100 S3 FRAME)	518199-S3	-/1/-	
	COVER SET, BED CROSS RAIL (FOR LX100 S4 FRAME)	518199-S4	-/-/1-	
	COVER SET, BED CROSS RAIL (FOR LX100 S5 FRAME)	518199-S5	-/-/1/1	
1	COVER, CROSS RAIL	518225	4/6/8/10	

**2.10 Additional Cross Bars w/Covers & Side Support Rollers (Option)**

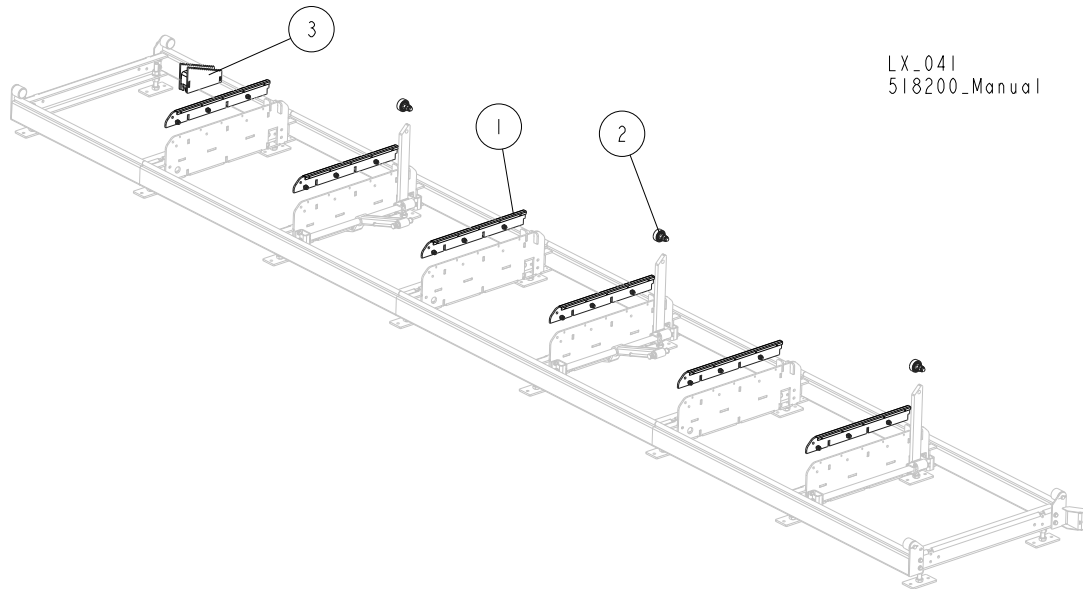

REF.	DESCRIPTION (◆ indicates parts available in assemblies only)	PART #	QTY
	◆ ADDITIONAL CROSS BARS W/COVERS & SIDE SUPPORT ROLLERS (FOR LX100 S2 FRAME)	518200-S2	1/-/-
	◆ ADDITIONAL CROSS BARS W/COVERS & SIDE SUPPORT ROLLERS (FOR LX100 S3 FRAME)	518200-S3	-1/-/-
	◆ ADDITIONAL CROSS BARS W/COVERS & SIDE SUPPORT ROLLERS (FOR LX100 S4 FRAME)	518200-S4	-/-1/-
	◆ ADDITIONAL CROSS BARS W/COVERS & SIDE SUPPORT ROLLERS (FOR LX100 S5 FRAME)	518200-S5	-/-/-1
1	BAR, CROSS W/COVER - ADDITIONAL <a href="#">See Section 2.11</a>	518180	4/2/8/10
2	ROLLER ASSEMBLY, SIDE SUPPORT <a href="#">See Section 2.12</a>	518181	2/3/4/5
3	WEDGE, LX100 WIDE BED	518204-1	1

## 2 BED FRAME PARTS

Additional Cross Bar w/Cover (Option)

### 2.11 Additional Cross Bar w/Cover (Option)

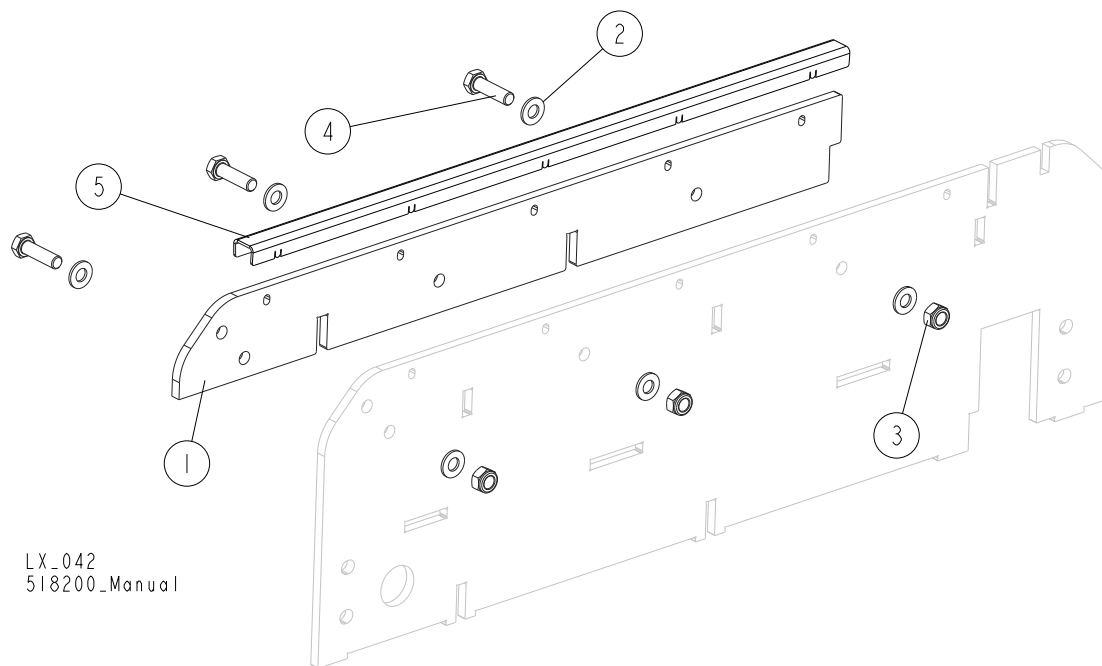

REF.	DESCRIPTION (◆ indicates parts available in assemblies only)	PART #	QTY
	<b>BAR, CROSS W/COVER - ADDITIONAL</b>	<b>518180</b>	<b>1</b>
1	BAR	517730	1
2	WASHER, 10.5 FLAT ZINC	F81055-1	6
3	NUT, M10-8-B HEX NYLON ZINC LOCK	F81033-1	3
4	BOLT, M10X35 8.8 HEX HEAD FULL THREAD ZINC	F81003-17	3
5	COVER, CROSS RAIL (WIDE)	518179	1

**2.12 Side Support Roller (Option)**

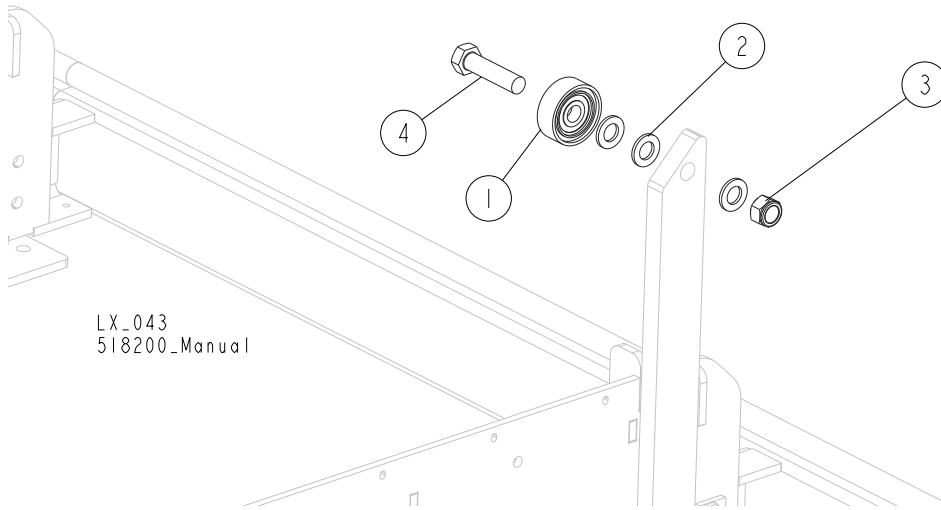

REF.	DESCRIPTION (◆ indicates parts available in assemblies only)	PART #	QTY
	<b>ROLLER ASSEMBLY, SIDE SUPPORT</b>	<b>518181</b>	<b>1</b>
1	ROLLER, SIDE SUPPORT	015014-1	1
2	WASHER, 17 SPLIT LOCK ZINC	F81058-1	3
3	NUT, M16-8 HEX NYLON ZINC LOCK	F81036-2	1
4	BOLT, M16x65-8.8-B HEX HEAD FULL THREAD ZINC	F81006-1	1

## SECTION 3 BLADE GUIDE ROLLERS & ARM

### 3.1 Blade Guide Assembly, Idle Side

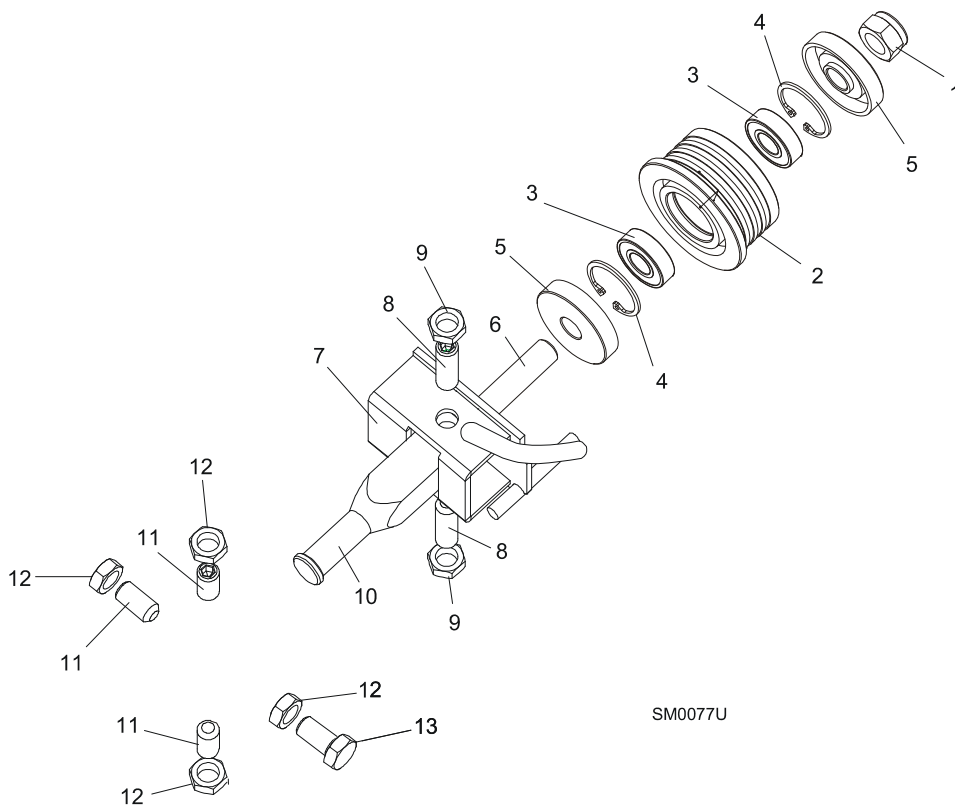

REF.	DESCRIPTION (◆ indicates parts available in assemblies only)	PART #	QTY	
	<b>BLADE GUIDE ASSEMBLY, IDLE SIDE</b>	094683	1	
	Roller, Blade Guide Complete Standard	087887	1	
<b>1</b>	Nut, M12-8 Hex Nylon Zinc Lock	F81034-2	1	
<b>2</b>	Roller, Blade Guide Narrow	087889	1	◆
<b>3</b>	Bearing, 6001 2RSR FAG	087893	2	
<b>4</b>	Ring, W28 Inside Retaining	F81090-9	1	
<b>5</b>	Washer, Zinc-plated Spacer	087891-1	2	
<b>6</b>	Shaft, Blade Guide Roller Zinc-plated	087763-1	1	
<b>7</b>	Bracket Weldment, Idle Side Blade Guide	094681-1	1	
<b>8</b>	Screw, M10x1x40 DIN 913 A2-70 Stainless Steel Set	F81015-2	2	
<b>9</b>	Nut, M10x1-04-ST-A2 ISO 8675 Thin	F81033-10	2	
<b>10</b>	Shaft, Zinc-plated Blade Guide Mount	503588-1	1	
<b>11</b>	<b>SCREW, M10X1X20 DIN 913 STAINLESS STEEL SET</b>	F81015-1	4	
<b>12</b>	<b>NUT, M10x1-04-ST-A2 ISO 8675 THIN</b>	F81033-10	4	

### 3.2 Blade Guide Assembly, Drive Side

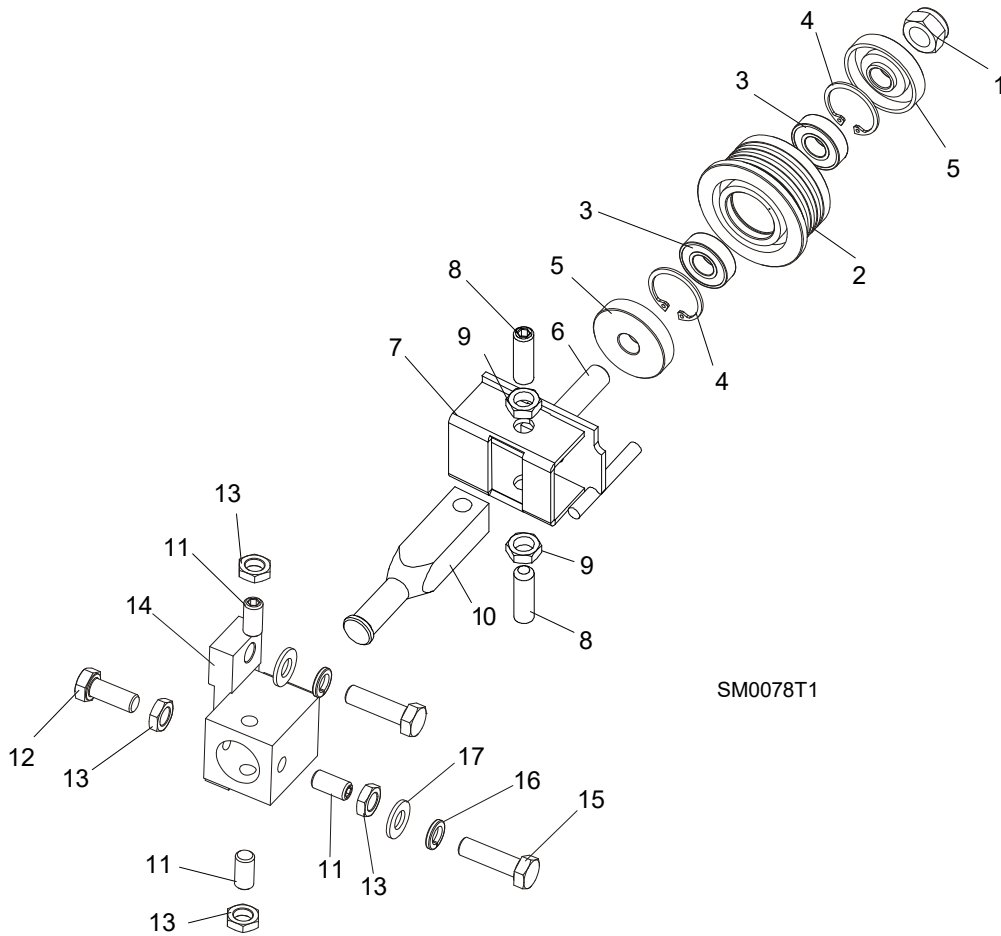

SM0078T1

REF.	DESCRIPTION (◆ indicates parts available in assemblies only)	PART #	QTY
	<b>BLADE GUIDE ASSEMBLY, COMPLETE DRIVE SIDE</b>	094682	1
	Roller, Blade Guide Complete Standard	087887	1
1	Nut, M12-8 Hex Nylon Zinc Lock	F81034-2	1
2	Roller, Blade Guide Narrow	087889	1
3	Bearing, 6001 2RSR FAG	087893	2
4	Ring, W28 Inside Retaining	F81090-9	1
5	Washer, Zinc-plated Spacer	087891-1	2
6	Shaft, Blade Guide Roller Zinc-plated	087763-1	1
7	Bracket Weldment, Blade Guide	094679-1	1
	Screw Kit, Blade Guide Adjustment w/Nuts (for two assemblies)	K09942	1
8	Screw, M10x1x40 DIN 913 A2-70 Stainless Steel Set	F81015-2	2
9	Nut, M10x1-04-ST-A2 ISO 8675 Thin	F81033-10	2
10	Shaft, Zinc-plated Blade Guide Mount	503588-1	1
11	<b>SCREW, M10X1X20 DIN 913 STAINLESS STEEL SET</b>	F81015-1	3
12	<b>BOLT, M10X1X25 DIN 933 STAINLESS STEEL</b>	F81003-28	1
13	<b>NUT, M10x1-04-ST-A2 ISO 8675 THIN</b>	F81033-10	4
14	<b>TUBE, BLADE GUIDE MOUNT</b>	087744	1
15	<b>BOLT, M10X35-8.8 HEX HEAD FULL THREAD ZINC</b>	F81003-17	2
16	<b>WASHER, 10.2 SPLIT LOCK ZINC</b>	F81055-2	2
17	<b>WASHER, 10.5 FLAT ZINC</b>	F81055-1	2

# 3 Blade Guide Rollers & Arm

## Blade Guide Roller Guard

### 3.3 Blade Guide Roller Guard

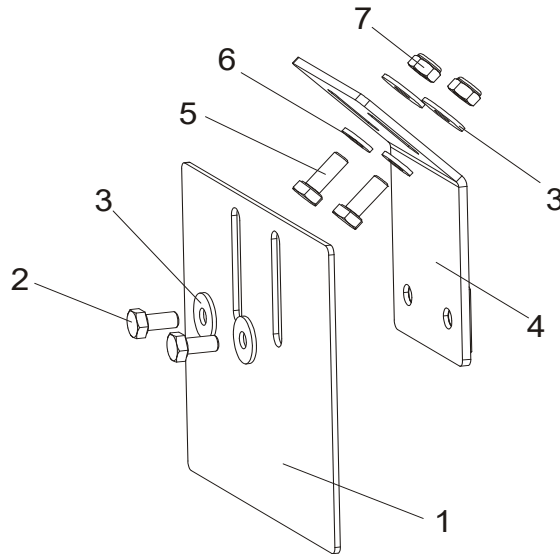

REF.	DESCRIPTION (◆ indicates parts available in assemblies only)	PART #	QTY
1	GUARD, BLADE GUIDE ROLLER	092379-1	1
2	BOLT, M6X12-8.8 HEX HEAD FULL THREAD ZINC	F81001-7	2
3	WASHER, 6.5 SPECIAL FLAT ZINC	F81053-11	4
4	BRACKET, ROLLER GUARD MOUNT	092378-1	1
5	BOLT, M6X16 8.8 HEX HEAD FULL THREAD ZINC	F81001-15	2
6	WASHER, 6.4 FLAT ZINC	F81053-1	2
7	NUT, M6-8-B HEX NYLON ZINC LOCK	F81031-2	2



### 3.4 Blade Guide Arm Assembly, E15

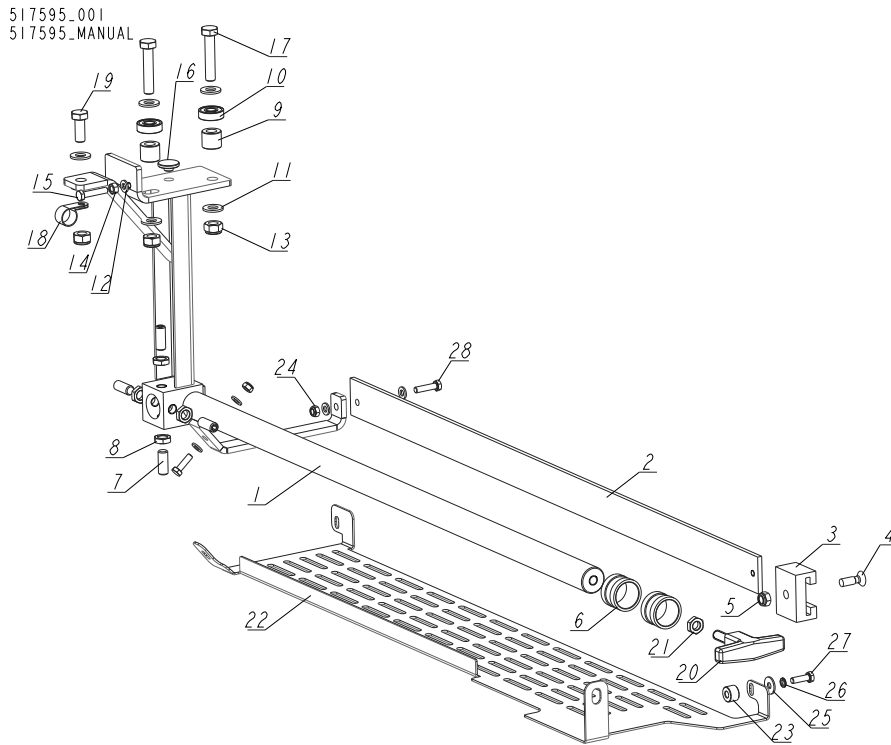

REF.	DESCRIPTION (◆ indicates parts available in assemblies only)	PART #	QTY
-	<b>ARM ASSEMBLY, BLADE GUIDE</b>	517595	1
1	ARM, ADJUSTABLE BLADE GUIDE	517379-1	1
2	BAR, BLADE GUARD	088306	1
3	GUIDE, BLADE GUARD	088305	1
4	SCREW, M8X25 CROSS RECESSED COUNTERSUNK HEAD ZINC	F81002-51	1
5	NUT, M8-8-B HEX NYLON ZINC LOCK	F81032-2	1
6	BUSHING, LT15 BLADE GUIDE	086684	2
7	SCREW, M10X1X25 DIN 913 STAINLESS STEEL SET	F81015-4	4
8	NUT, M10X1-04-ST-A2E ISO8675 THIN	F81033-10	4
9	BUSHING, 11/20-17 ZINC-PLATED	094255-1	2
10	BEARING, 6000.2RSR	087471	2
11	WASHER, 10.5 FLAT ZINC	F81055-1	6
12	WASHER, 6.4 FLAT ZINC	F81053-1	5
13	NUT, M10-8-B HEX NYLON ZINC LOCK	F81033-1	3
14	NUT, M6 8 HEX ZINC	F81031-1	1
15	BOLT, M6X30-5.6 HEX HEAD FULL THREAD	F81001-13	1
16	BUSHING, BLADE GUIDE ARM	095936	1
17	BOLT, M10X50-8.8 HEX HEAD FULL THREAD ZINC	F81003-4	2
18	CLAMP, 5/8 EMT COATED	010748	1
19	BOLT, M10X25 8.8 HEX HEAD FULL THREAD ZINC	F81003-11	1
20	T-GRIP, K0180.28010X30 W/EXTERNAL THREAD	517600	1
21	NUT, M10-04-A THIN ZINC	F81033-6	1
22	GUARD, BOTTOM	525594-1	1
23	BUSHING, 6.5/16-10.5	525463-1	1
24	NUT, M6-8-B HEX NYLON ZINC LOCK	F81031-2	2

REF.	DESCRIPTION (◆ indicates parts available in assemblies only)	PART #	QTY	
25	WASHER, 6.5 SPECIAL FLAT ZINC	F81053-11	1	
26	WASHER, Z 6.1 SPLIT LOCK ZINC	F81053-3	1	
27	BOLT, M6X20 8.8 HEX HEAD FULL THREAD ZINC	F81001-2	2	
28	BOLT, M6X25 5.8 HEX HEAD FULL THREAD ZINC	F81001-3	1	

### 3.5 Blade Guide Arm w/Drive

517381\_001  
517381\_MANUAL

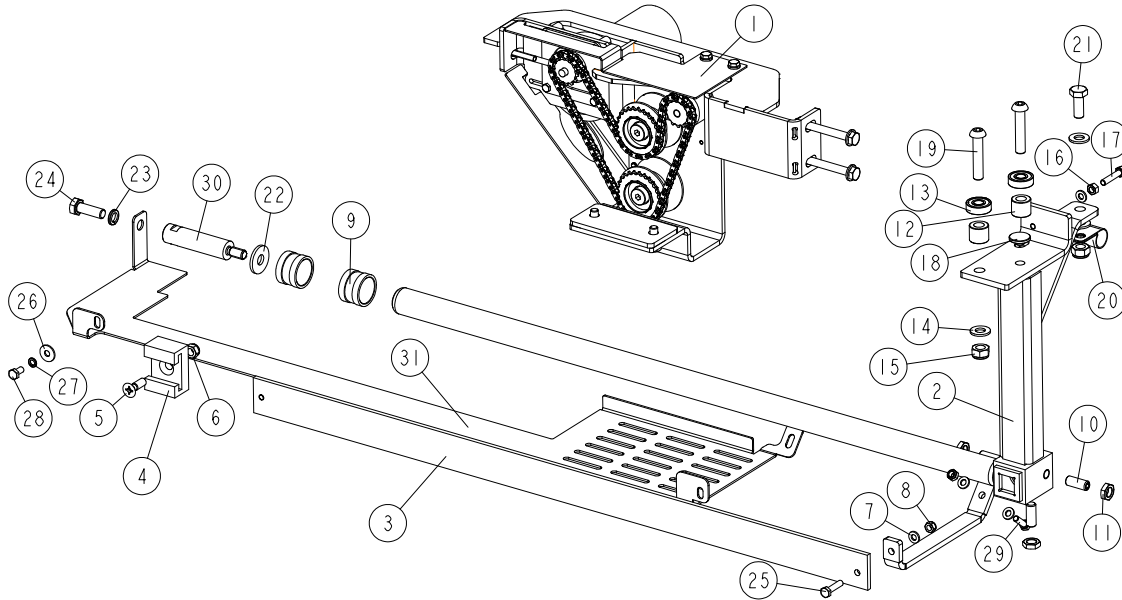

REF	DESCRIPTION (* indicates parts available in assemblies only)	PART #	QTY
-	<b>ARM W/DRIVE, BLADE GUIDE</b>	517381	1
1	DRIVE ASSEMBLY, BLADE GUIDE ARM <a href="#">See Section 3.6</a>	517270	1
-	<b>ARM ASSEMBLY, BLADE GUIDE</b>	517380	1
2	ARM, BLADE GUIDE ADJUSTABLE	517379-1	1
3	BAR, BLADE GUARD	088306	1
4	BRACKET, BLADE GUIDE ARM GUIDE	088305	1
5	BOLT, M8X25 PAN HEAD ZINC	F81002-51	1
6	NUT, M8-8-B HEX NYLON ZINC LOCK	F81032-2	1
7	WASHER, 6.4 FLAT ZINC	F81053-1	4
8	NUT, M6-8-B HEX NYLON ZINC LOCK	F81031-2	2
9	BUSHING, BLADE GUIDE	086684	2
10	SCREW, M10X1X25 DIN 913 STAINLESS STEEL	F81015-4	4
11	NUT, M10X1-04-ST-A2 ISO 8675 THIN	F81033-10	4
12	BUSHING, 11/20-17 ZINC-PLATED	094255-1	2
13	BEARING, 6000.2RSR	087471	2
14	WASHER, 10.5 FLAT ZINC	F81055-1	4
15	NUT, M10-8-B HEX NYLON ZINC LOCK	F81033-1	3
16	NUT, M6 8 HEX ZINC	F81031-1	1
17	BOLT, M6X30-8.8 HEX HEAD FULL THREAD	F81001-13	1
18	BUSHING, BLADE GUIDE ARM	095936	1
19	BOLT, M10X50-8.8 HEX HEAD FULL THREAD ZI	F81003-131	2
20	CLAMP, 5/8 EMT COATED	010748	1
21	BOLT, M10X25 8.8 HEX HEAD FULL THREAD ZI	F81003-11	1
22	WASHER, 11/30-3 ZINC-PLATED	088787-1	1
23	WASHER 10,2 ZC SPRING LOCK DIN 127	F81055-2	1
24	BOLT, M10X30-8.8 HEX HEAD FULL THREAD ZI	F81003-2	1

**3****Blade Guide Rollers & Arm***Blade Guide Arm w/Drive*

---

REF	DESCRIPTION (* indicates parts available in assemblies only)	PART #	QTY	
25	BOLT, M6X25 -8.8 HEX HEAD FULL THREAD ZI	F81001-3	1	
26	WASHER, 6.5 SPECIAL FLAT ZINC	F81053-11	1	
27	WASHER, Z 6.1 SPLIT LOCK ZINC	F81053-3	1	
28	BOLT, M6X12 8.8 HEX HEAD FULL THREAD ZIN	F81001-7	1	
29	BOLT, M6X20 8.8 HEX HEAD FULL THREAD ZIN	F81001-2	1	
30	ROD N20/M10	555473-1	1	
31	BOTTOM GUARD	555474-1	1	

### 3.6 Blade Guide Arm Drive

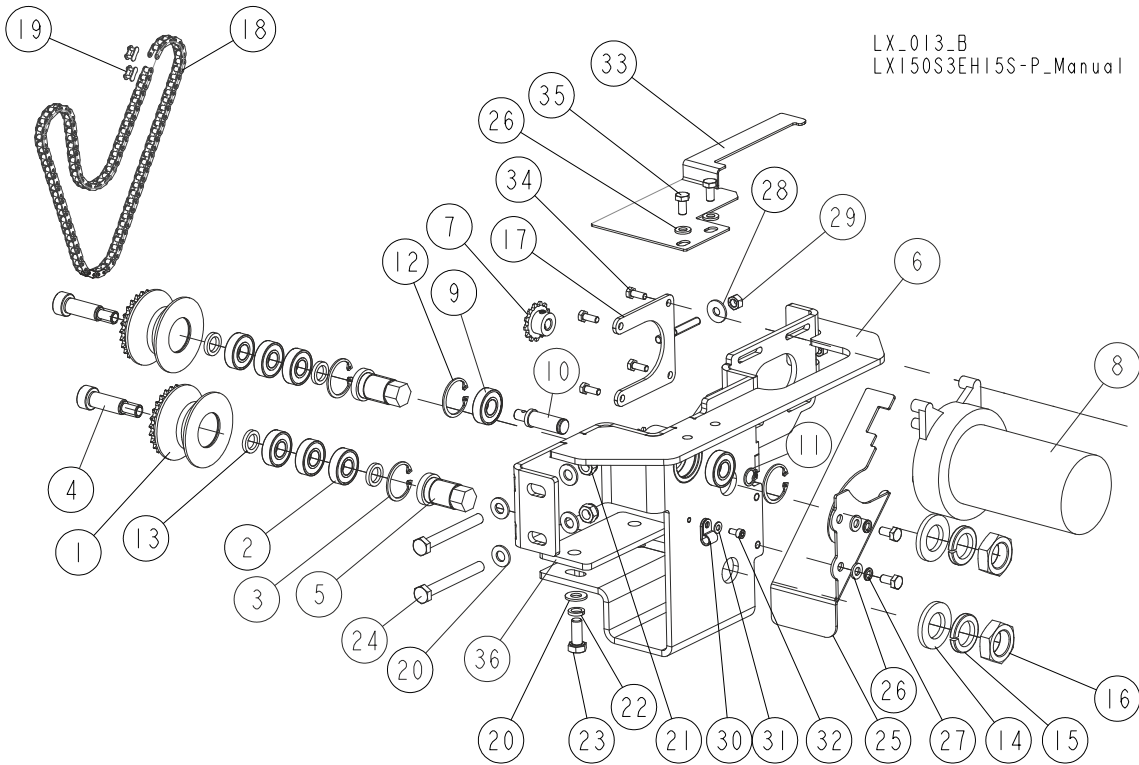

LX\_013\_B  
LX150S3EH15S-P\_Manual

REF.	DESCRIPTION (◆ indicates parts available in assemblies only)	PART #	QTY
-	DRIVE ASSEMBLY, BLADE GUIDE ARM	517270	1
-	COMPLETE ROLLER	517269	2
1	ROLLER W/SPROCKET	517253-1	1
2	BEARING, 6001 2RSR (FAG, SKF)	087893	3
3	RING, W28 INSIDE RETAINING	F81090-9	1
4	BOLT, 12/M10x30 12.9 ISO7379 SHOULDER	F81003-70	2
5	BOLT, ECCENTRIC	517257-1	2
6	PLATE, MOUNTING - COMPLETE	517259-1	1
7	SPROCKET ASSEMBLY, 25B13X.3130	P09970	2
8	MOTOR, 1/30HP 62RPM 12VDC 53:1 GEAR CE	P09698-1-CE	1
9	BEARING, 6001 2RSR (FAG, SKF)	087893	2
10	SHAFT, IDLER	517260	1
11	RING, Z12 OUTSIDE RETAINING	F81090-14	1
12	RING, W28 INSIDE RETAINING	F81090-9	2
13	WASHER, 12.3/18-3	517256	4
14	WASHER, 21 FLAT ZINC	F81059-2	2
15	WASHER, 20.5 SPLIT LOCK ZINC	F81059-1	2
16	NUT, M20X1.5 THIN ZINC	F81037-7	2
17	TENSIONER, DEBARKER MOTOR	089969-1	1
-	CHAIN, BLADE GUIDE ARM DRIVE	517267	1
18	Chain, #25x98-Link	517266	1
19	Link, 25 Master	P09983	2
20	WASHER, 8.4 FLAT ZINC	F81054-1	6
21	NUT, M8-8-B HEX NYLON ZINC LOCK	F81032-2	2

REF.	DESCRIPTION (◆ indicates parts available in assemblies only)	PART #	QTY	
22	WASHER, 8.2 SPLIT LOCK ZINC	F81054-4	2	
23	BOLT, M8X20 8.8 HEX HEAD FULL THREAD ZINC	F81002-4	2	
24	BOLT, M8x70-8.8 HEX HEAD ZINC	F81002-71	2	
25	GUARD, CHAIN	517268-1	1	
26	WASHER, 6.4 FLAT ZINC	F81053-1	4	
27	WASHER, Z 6.1 SPLIT LOCK ZINC	F81053-3	2	
28	WASHER, 6.5 SPECIAL FLAT ZINC	F81053-11	1	
29	NUT, M6 8 HEX ZINC	F81031-1	2	
30	ELEMENT, EE63 MOUNTING	F81080-4	1	
31	WASHER, 4.3 FLAT ZINC	F81051-2	1	
32	SCREW, M4X8 8.8 HEX SOCKET HEAD CAP ZINC	F81011-36	1	
33	GUARD, UPPER	517262-1	1	
34	BOLT, #10-32x1/2 HH	F05004-60	4	
35	BOLT, M6X12 8.8 HEX HEAD FULL THREAD ZINC	F81001-7	4	
36	WASHER	525604-1	1	

## SECTION 4 BLADE WHEELS & TENSIONER

### 4.1 Blade Wheel Assembly, Drive Side (E15)

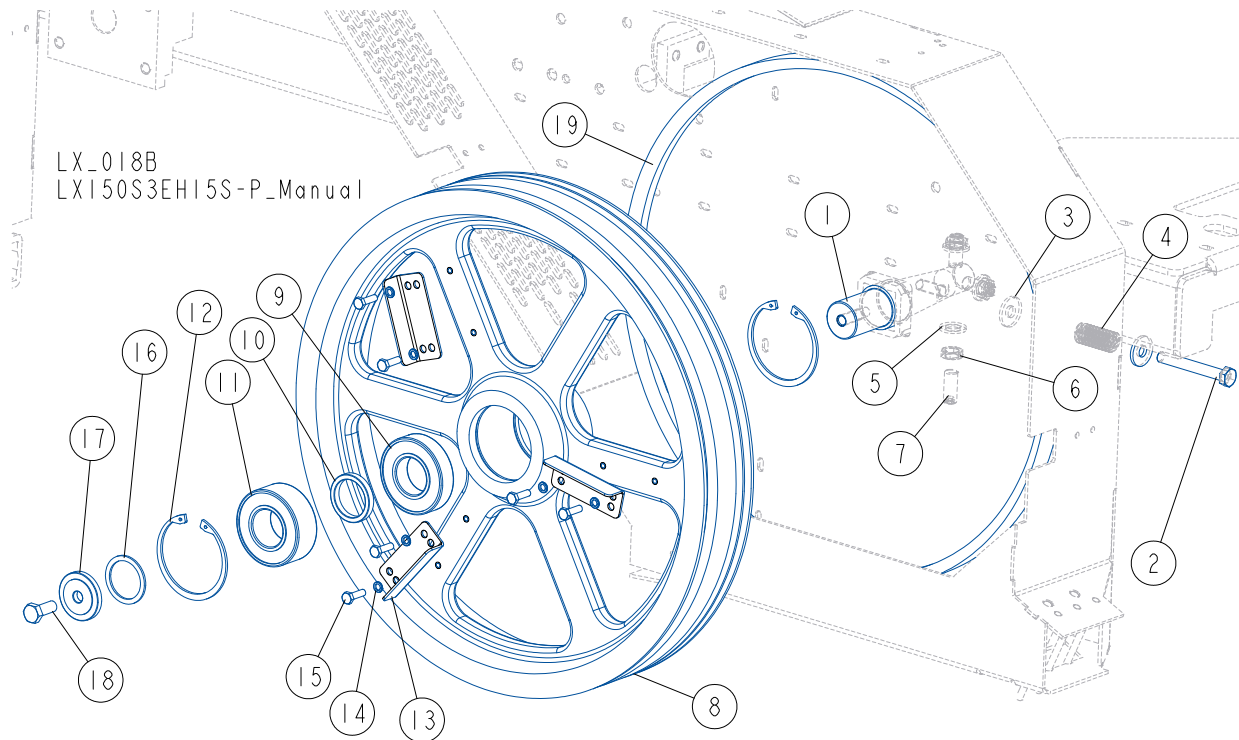

LP.	OPIS (* wskazuje części dostępne jedynie w zespołach)	Nr części	Ilość
1	SHAFT, LT15 DRIVE SIDE BLADE WHEEL	093850	1
2	BOLT, M10X75-8.8 HEX HEAD ZINC	F81003-15	1
3	WASHER, 10.5 SPECIAL FLAT ZINC	F81055-6	2
4	SPRING, 3/4 O.D.X 1 1/2 DIE	034430	1
5	WASHER, 13 FLAT ZINC	F81056-1	3
6	NUT, M12X1.25 DIN 439 A2-70 THIN STAINLESS STEEL	F81034-9	3
7	SCREW, M12X1.25X30 DIN913 A2-70 SET	F81016-1	3
-	WHEEL, DRIVE SIDE - COMPLETE	091612	1
8	WHEEL, DRIVE SIDE	538726-1	1
9	BEARING, 6207-2RS, C3, 35X72X17	014811	1
10	BUSHING, SPACER	096778	1
11	BEARING, 3207B.2RSR.TVH "FAG"	092005	1
12	RING, W72 INSIDE RETAINING	F81090-4	2
13	WING	097808-1	3
14	WASHER, Z 6.1 SPLIT LOCK ZINC	F81053-3	6
15	BOLT, M6X20 8.8 HEX HEAD FULL THREAD ZINC	F81001-2	6
16	WASHER, 36/45-2	091851	1
17	WASHER, DRIVE SIDE BLADE WHEEL	092006	1
18	BOLT, M10X25 8.8 HEX HEAD FULL THREAD ZINC	F81003-11	1
19	BELT, B57 BLADE WHEEL	P04185-2	1

## 4.2 Blade Wheel Assembly, Drive Side - E10

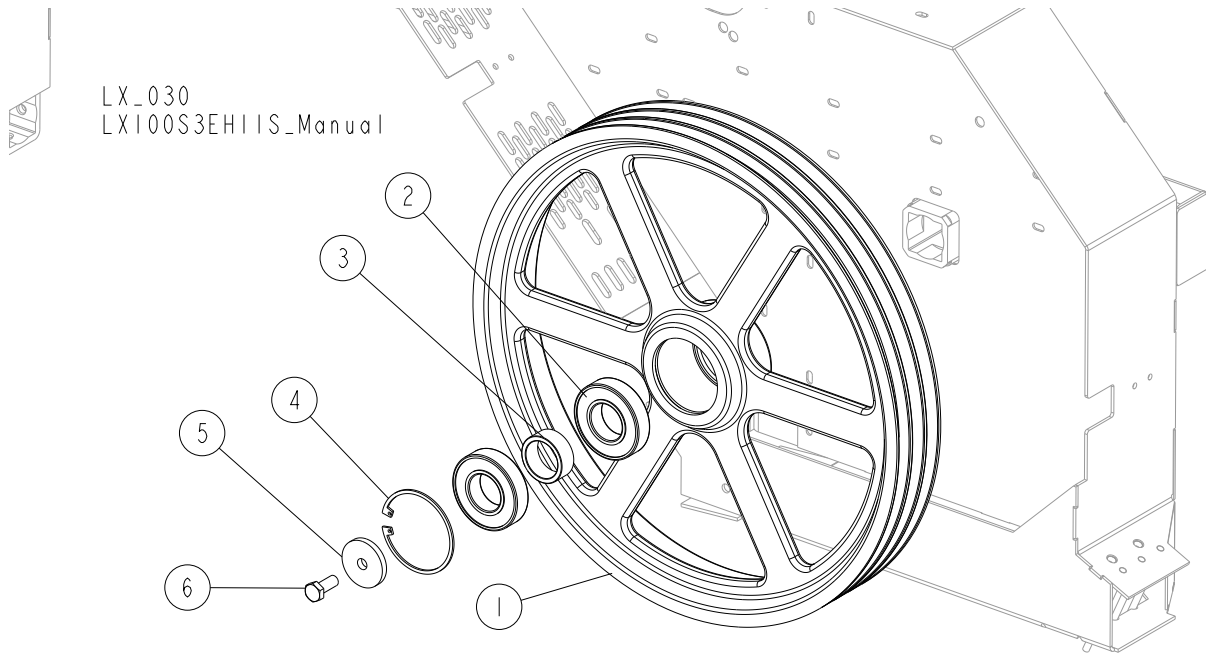

REF.	DESCRIPTION (◆ indicates parts available in assemblies only)	PART #	QTY
	<b>WHEEL, LT15 DRIVE SIDE - COMPLETE</b>	<b>093849</b>	<b>1</b>
1	WHEEL, 19" METRIC DRIVE SIDE	096901-1	1
2	BEARING, 6207-2RS C3 35X72X17	014811	2
3	BUSHING, 35.5/45-17.8	093851	1
4	RING, 72MM OD RETAINING N5002-281	F04254-30	1
5	<b>WASHER, 10.5/45-6 ZINC-PLATED</b>	086286-1	1
6	<b>BOLT, M10X25 8.8 HEX HEAD FULL THREAD ZINC</b>	F81003-11	1



**4.3 Blade Wheel Assembly, Idle Side**

LX\_019  
LX150S3EH15S-P\_Manual

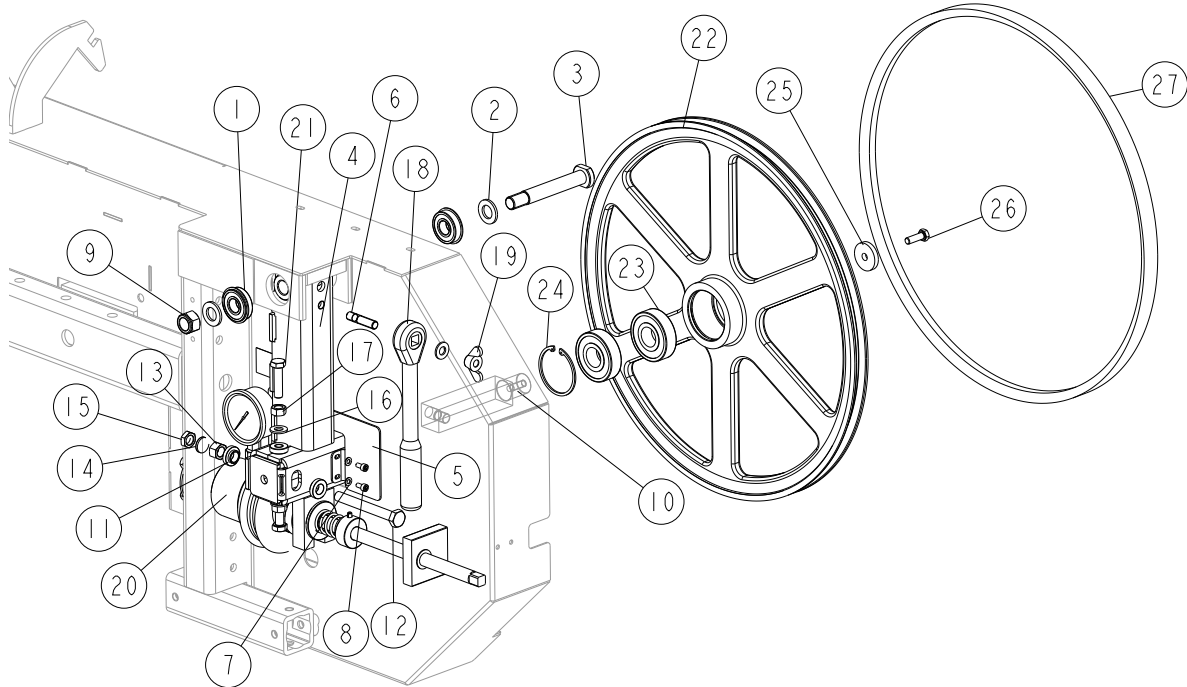

REF.	DESCRIPTION (◆ indicates parts available in assemblies only)	PART #	QTY
1	BEARING, 6203-2RS NR NSK W/SNAP RING	086395	2
2	WASHER, 17 SPLIT LOCK ZINC	F81058-1	2
3	PIN, IDLER ARM MOUNT	086404	1
	<b>ROCKER ARM, IDLE SIDE BLADE WHEEL - COMPLETE</b>	<b>508145</b>	<b>1</b>
4	ROCKER ARM WELDMENT, IDLE SIDE BLADE WHEEL	508144-1	1
5	GUARD, ROCKER ARM	508128-1	1
6	STUD, M10X35 8.8 ZINC-PLATED	F81003-9	1
7	WASHER, 5.3 FLAT ZINC	F81052-1	3
8	SCREW, M5X10 DIN 912 A2-70 HEX SOCKET HEAD CAP STAINLESS STEEL	F81000-23	3
9	NUT, M16-8 HEX NYLON ZINC LOCK	F81036-2	1
10	SHAFT, IDLE SIDE BLADE WHEEL	096045	1
11	WASHER, FLANGED ZINC-PLATED	086769-1	2
12	BOLT, M12X1.25X100-8.8 HEX HEAD FULL THREAD ZINC	F81004-41	1
13	NUT, M12X1.25-8-B HEX ZINC	F81034-8	1
14	WASHER, Z12.2 SPLIT LOCK ZINC	F81056-2	1
15	NUT, M12X1.25-8 THIN ZINC	F81034-5	1
16	WASHER, 10.5 FLAT ZINC	F81055-1	3
17	NUT, M10 8 HEX ZINC	F81033-3	2
18	WRENCH, LT20 BLADE TENSION	091620	1
19	NUT, M10 ZINC-PLATED WING	F81033-8	1
20	COMPLETE BLADE TENSIONER <a href="#">See Section 4.4</a>	510640	1
21	BOLT, M10X40-8.8 HEX HEAD FULL THREAD ZINC	F81003-16	2
	<b>PULLEY ASSY, 19" (482.6MM) BLADE IDLE SIDE</b>	<b>A08218</b>	<b>1</b>

## 4

**BLADE WHEELS & TENSIONER***Blade Wheel Assembly, Idle Side*

REF.	DESCRIPTION (◆ indicates parts available in assemblies only)	PART #	QTY	
22	SHEAVE, 18.62 IDLER	P08125	1	
23	BEARING,.9843X2.4409X.6693	P08066	2	
24	RING, 2 7/16 IR N 5002-244 BEVELED SNAP	F04254-21	1	
25	<b>WASHER, 9/35-6 ZINC-PLATED</b>	093854-1	1	
26	<b>BOLT, M8X25-8.8-B HEX HEAD FULL THREAD ZINC</b>	F81002-5	1	
27	<b>BELT, B57 BLADE WHEEL</b>	P04185-2	1	

**4.4 Blade Tensioner Assembly**

510640\_001  
510640\_MANUAL

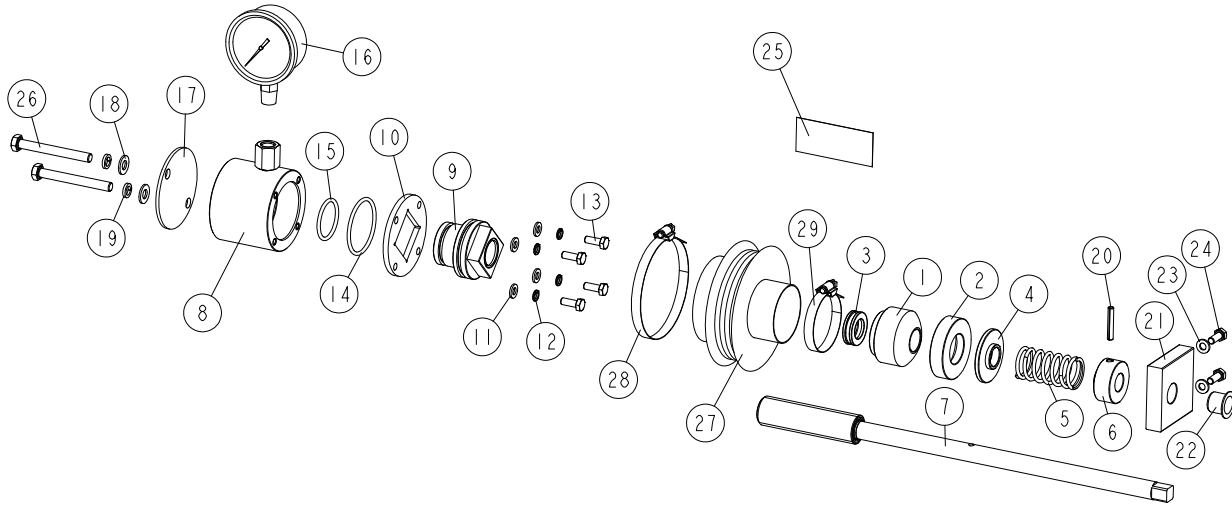

REF	DESCRIPTION (u indicates parts available in assemblies only)	PART #	QTY
-	<b>COMPLETE BLADE TENSIONER</b>	510640	1
1	HOUSING, BALL THRUST BEARING	510635	1
2	SOCKET, BEARING HOUSING	510634-1	1
3	BEARING, 51103. BALL THRUST	086675	1
4	WASHER	510633-1	1
5	SPRING, 60X23X3	088992	1
6	BUSHING, BLADE TENSIONER SCREW	510636-1	1
7	SCREW, BLADE TENSIONER ZINC-PLATED	510650-1	1
-	<b>CYLINDER ASSEMBLY</b>	510641	1
8	CYLINDER ASSEMBLY WITH REDUCTION	550762-1	1
9	PISTON	510638	1
10	PLATE, CYLINDER	510490-1	1
11	WASHER, 6.4 FLAT ZINC	F81053-1	4
12	WASHER, Z 6.1 SPLIT LOCK	F81053-3	4
13	BOLT, M6X16-5.8 HEX HEAD FULL THREAD ZIN	F81001-15	4
14	O-RING, 46.2X3	510646	1
15	O-RING, 32.2X3	510647	1
16	GAUGE, 3000PSI/200 BAR OIL PRESSURE	505176	1
17	COVER, TENSIONER	550761-1	1
18	WASHER, 8.4 FLAT ZINC	F81054-1	2
19	WASHER 8,2 SPLIT LOCK ZINC	F81054-4	2
20	PIN 5X30 ROLL	F81044-21	1
21	BLOCK, TENSIONER HANDLE MOUNT	096730	1
22	BUSHING, GFM-1618-17	089589	1
23	WASHER, 6.4 FLAT ZINC	F81053-1	2
24	BOLT, M6X16-5.8 HEX HEAD FULL THREAD ZIN	F81001-15	2
25	DECAL, BLADE TENSION INDICATOR ADJUSTMEN	510643	1
26	BOLT, M8X70-8.8 HEX HEAD ZINC	F81002-71	2
-	<b>BELLOWS, COMPLETE</b>	515050	1
27	BELLOWS	515051	1

**4****BLADE WHEELS & TENSIONER***Blade Tensioner Assembly*

---

REF	DESCRIPTION (u indicates parts available in assemblies only)	PART #	QTY	
28	CLAMP, 70-80MM DIA.	F81095-5	1	
29	CLAMP, 40-60MM DIA.	F81095-4	1	

## SECTION 5 SAW HEAD

### 5.1 Blade Housing Cover

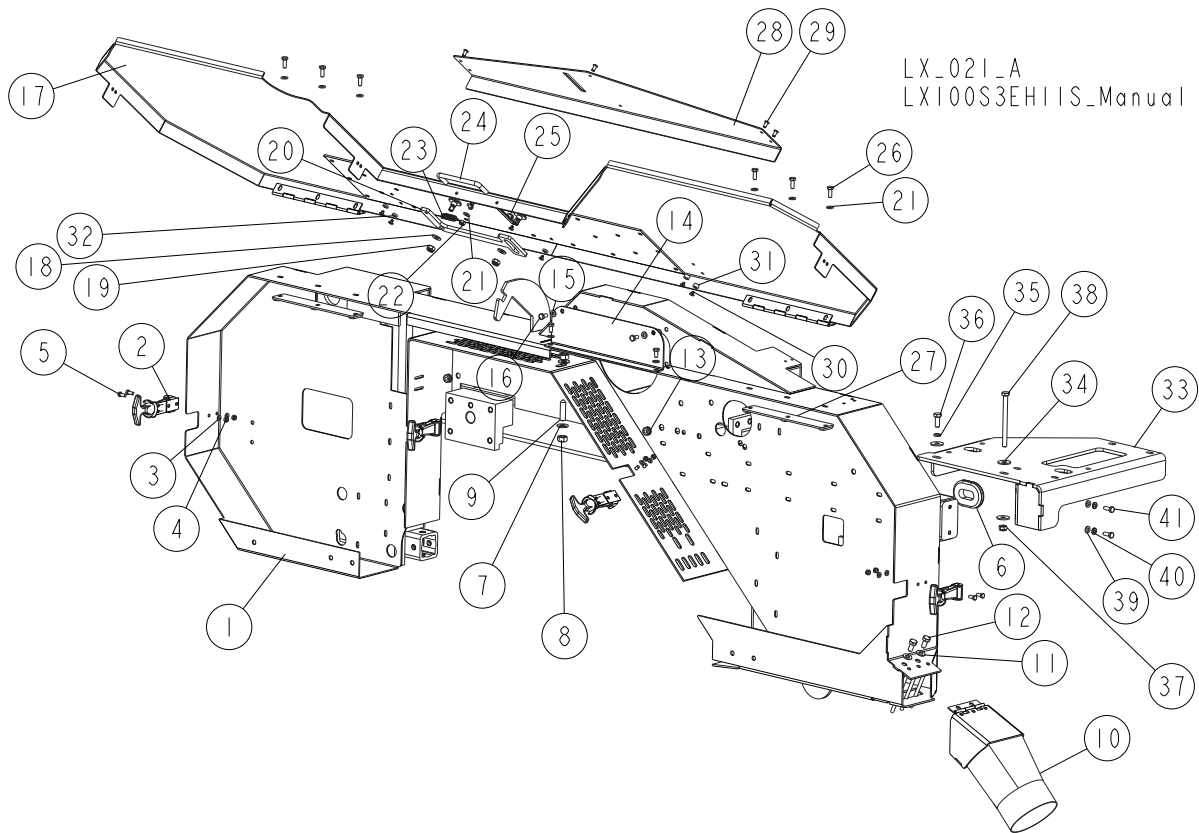

REF.	DESCRIPTION (* Indicates Parts Available In Assemblies Only)	PART #	QTY
1	SAW HEAD, LT0 AC PAINTED	097560-1	1
2	LATCH, FLEXIBLE DRAW	014829	4
3	WASHER, 5.3 FLAT ZINC	F81052-1	8
4	NUT, M5-8-FE/ZN5 DIN985	F81030-2	8
5	BOLT, M5 X 12-5.8 HEX HEAD FULL THREAD ZINC	F81000-5	8
6	GROMMET, RUBBER, 1 X 1 3/4 OVAL	085613	1
7	WASHER, 10.5 FLAT ZINC	F81055-1	2
8	NUT, M10-8-B HEX ZINC	F81033-3	2
9	SCREW, M10X40-45H CONE POINT HEX SOCKET	F81003-61	1
10	CHUTE, LT10/15/20 SAWDUST	100903-1	1
11	WASHER, 8.4 FLAT ZINC	F81054-1	2
12	BOLT, M8X16-8.8-B HEX HEAD FULL THREAD ZINC	F81002-20	2
13	SEAL WIRE, GH6	085338	2
14	PLATE, COVER	096788-1	1
15	WASHER, 6.4 FLAT ZINC	F81053-1	4
16	BOLT, M6X12-8.8 HEX HEAD FULL THREAD ZINC	F81001-7	4
	<b>COVER, SAW HEAD FRONT</b>	<b>518030</b>	<b>1</b>
17	<b>COVER, SAW HEAD FRONT</b>	518025-1	1
18	WASHER, 8.4 FLAT ZINC	F81054-1	2
19	NUT, M8-8-B HEX NYLON ZINC LOCK	F81032-2	2



## Saw Head

### Blade Housing Cover

REF.	DESCRIPTION (* Indicates Parts Available In Assemblies Only)	PART #	QTY	
20	PAWL, LOCKING	090643-1	1	
21	WASHER, 6.4 FLAT ZINC	F81053-1	8	
22	NUT, M6-8-B HEX NYLON ZINC LOCK	F81031-2	1	
23	SPRING, 1.6X12X38 EXTENSION	092208	1	
24	HANDLE, 4" W/BOLTS	P08065	1	
25	BOLT, #8-32X3/8 SELF-TAPPING	F05015-8	2	
26	BOLT, M6 X 16 8.8 HEX HEAD FULL THREAD ZINC	F81001-15	6	
27	PLATE WELDMENT, COVER MOUNTING	086701-1	2	
28	PLATE, DECORATIVE	518029-1	1	
29	SCREW, 1918 DIA. BINDING (FEMALE PART - 10 MM LONG)	518033	6	
30	SCREW, 1918 DIA. BINDING (MALE PART - 6 MM LONG)	518034	6	
31	BUSHING, 1941 DIA. (5.2/10-6) SPACER	518159	2	
32	WASHER, 1940 DIA. (5.2/10-3)	518158	4	
	<b>PLATE , MOUNTING COMPLETE</b>	<b>518165</b>	<b>1</b>	
33	PLATE, MOUNTING	518164-1	1	
34	WASHER, ISO 7093-1-8-200 HV-A2E	F81054-11	3	
35	WASHER, 8.2 ZINC-PLATED	F81054-4	1	
36	BOLT, M8X20-5.8 HEX HEAD FULL THREAD ZINC	F81002-1	1	
37	NUT, M8-8-B HEX NYLON ZINC LOCK	F81032-2	1	
38	BOLT, M8 X 100-8.8 HEX HEAD ZINC	F81002-23	1	
39	WASHER, 6.4 FLAT ZINC	F81053-1	2	
40	WASHER, 6.1 DIN 127 (A2-304) STAINLESS STEEL SPRING	F81053-4	2	
41	BOLT, M6 X 16 8.8 HEX HEAD FULL THREAD ZINC	F81001-15	2	

## 5.2 Water Lube Assembly

LX\_010\_C  
LX100S3EH11S\_MANUAL

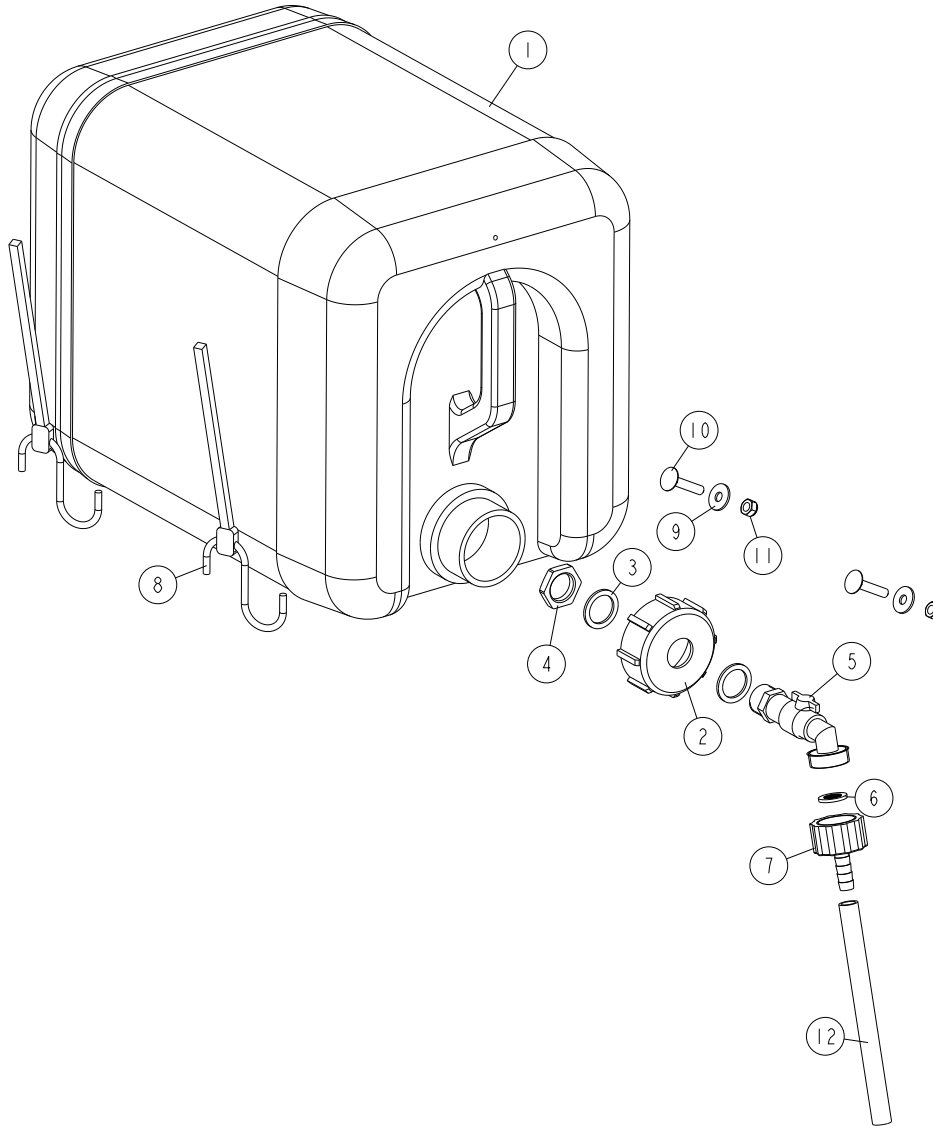

REF	DESCRIPTION (u indicates parts available in assemblies only)	PART #	QTY
-	BOTTLE ASSEMBLY, WATER	517110	1
-	TANK, OIL	550787	1
1	BOTTLE, WATER	513866	1
2	NUT, BOTTLE	550785	1
3	SEAL, 27X20X1.5 ESSENTRA 467673 RUBBER	550780	2
4	NUT, 1/2 ESSENTRA 467615 GLAND	550779	1
5	FITTING, WATER LUBE SHUTOFF VALVE	550776	1
6	FILTER, WATER LUBE	550778	1
7	FITTING, G3/4" X 10MM HOSE BARB	550777	1
8	STRAP, 24" RUBBER (FOR FUEL TANK - SEE E	P11258	2
9	WASHER, FLAT ZINC	F81053-11	2
10	BOLT, M6X30-8.8 CARRIAGE ZINC	F81001-59	2

**5****Saw Head***Water Lube Assembly*

---

REF	DESCRIPTION (u indicates parts available in assemblies only)	PART #	QTY	
11	NUT, M6-8-B HEX NYLON ZINC LOCK	F81031-2	2	
12	TUBING, WATER LUBE 3/8" I.D.	R01885	1	



### 5.3 Slide Pads

LX\_022\_A  
LX100S3EHIIS\_Manual

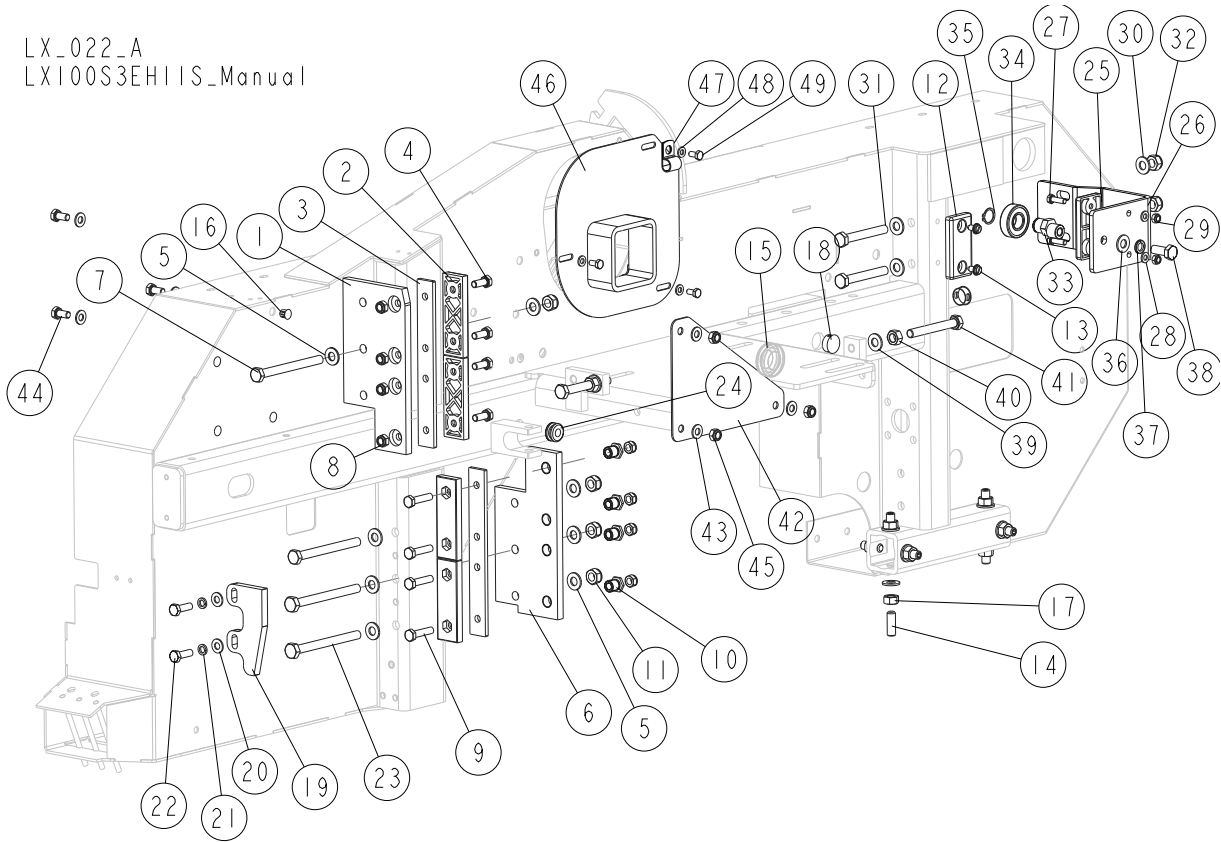

REF.	DESCRIPTION (* Indicates Parts Available In Assemblies Only)	PART #	QTY
1	PLATE, SAW HEAD UPPER GUIDE	094139-1	1
2	PADS, DELRIN UP/DOWN SLIDE	M04096	4
3	PLATE, SLIDE PAD SPACER	094140-1	2
4	BOLT, M8X20-8.8-B HEX HEAD FULL THREAD ZINC	F81002-4	4
5	WASHER, 10.5 FLAT ZINC	F81055-1	16
6	PLATE, SAW HEAD LOWER ZINC-PL. GUIDE	086682-1	1
7	BOLT, M10X110-8.8 HEX HEAD ZINC	F81003-43	2
8	NUT, M8-8-B HEX NYLON ZINC LOCK	F81032-2	8
9	BOLT, M8X35-8.8 HEX HEAD FULL THREAD ZINC	F81002-13	4
10	NUT, LT15 SLIDE PAD ADJUSTMENT ZINC-PLATED	086683-1	4
11	NUT, M10-8-B HEX NYLON ZINC LOCK	F81033-1	4
12	PAD, CATAPILLAR TRACK	P13576	1
13	SCREW, 1/4-20X1/2" TYPE "23" SELF-TAPPING	F05015-1	2
14	SCREW, M10X30-33H-GEOMET HEX SOCKET SET FLAT POINT	F81003-35	8
15	GROMMET, 22MM I.D. RUBBER	087400	1
16	PLUG, SR1086-9.5 NO. 46009 (MOSS) 096846 4	096846	4
17	NUT, M10-8-B HEX ZINC	F81033-3	8
18	PLUG, 20.6 HEYMAN DP-812 HOLE	086811	3
	PLATE, LIMIT SWITCH ACTIVATOR - COMPLETE	<b>516510</b>	<b>1</b>
19	PLATE, LIMIT SWITCH ACTIVATOR	516509-1	1
20	WASHER, 8.4 FLAT ZINC	F81054-1	2
21	WASHER, 8.2 SPLIT LOCK ZINC	F81054-4	2

# 5 Saw Head

## Slide Pads

REF.	DESCRIPTION (* Indicates Parts Available In Assemblies Only)	PART #	QTY
22	BOLT, M8X25-8.8-B HEX HEAD FULL THREAD ZINC	F81002-5	2
23	BOLT, M10 X 115-8.8 HEX HEAD ZINC	F81003-19	2
24	GROMMET, RUBBER 3/8 ID	025248	1
	<b>BRACKET, RIGHT SLIDE PAD - COMPLETE</b>	<b>518170</b>	<b>1</b>
25	PAD, CATAPILLAR TRACK	P13576	1
26	BRACKET, UPPER	518183-1	1
27	BOLT, M6X20-8.8 HEX HEAD FULL THREAD ZINC	F81001-2	2
28	WASHER, 6.4 FLAT ZINC	F81053-1	2
29	NUT, M6-8-B HEX NYLON ZINC LOCK	F81031-2	2
30	WASHER, 10.5 FLAT ZINC	F81055-1	4
31	BOLT, M10X75-8.8 HEX HEAD ZINC	F81003-15	2
32	NUT, M10-8-B HEX NYLON ZINC LOCK	F81033-1	2
	<b>ROLLER ASSEMBLY, ECCENTRIC</b>	<b>518182</b>	<b>1</b>
33	SHAFT, E=3.3 ECCENTRIC ZINC-PLATED	531678-1	1
34	BEARING, 6203-2RS	086114	1
35	RING, Z17 OUTSIDE RETAINING	F81090-21	1
36	WASHER, 10.5 FLAT ZINC	F81055-1	1
37	WASHER, 10.2 SPLIT LOCK ZINC	F81055-2	1
38	BOLT, M10X25-8.8 HEX HEAD FULL THREAD ZINC	F81003-11	1
39	<b>WASHER, 10.5 FLAT ZINC</b>	F81055-1	2
40	<b>NUT, M10-8-B HEX ZINC</b>	F81033-3	2
41	<b>BOLT, M10-80-8.8 HEX HEAD FULL THREAD ZINC</b>	F81003-76	2
42	<b>CAP, BOLTED</b>	094247-1	1
43	<b>WASHER, 8.4 FLAT ZINC</b>	F81054-1	6
44	<b>BOLT M8X16-8.8-B HEX HEAD FULL THREAD ZINC</b>	F81002-20	3
45	<b>NUT, M8-8-B HEX NYLON ZINC LOCK</b>	F81032-2	3
46	<b>GUARD, E11/E15 MOTOR SHAFT</b>	095335-1	1
47	<b>CLAMP, 1/2EMT COATED</b>	P07584	1
48	<b>WASHER, 6.4 FLAT ZINC</b>	F81053-1	3
49	<b>BOLT, M6X12-8.8 HEX HEAD FULL THREAD ZINC</b>	F81001-7	3

## 5.4 Saw Head Decals

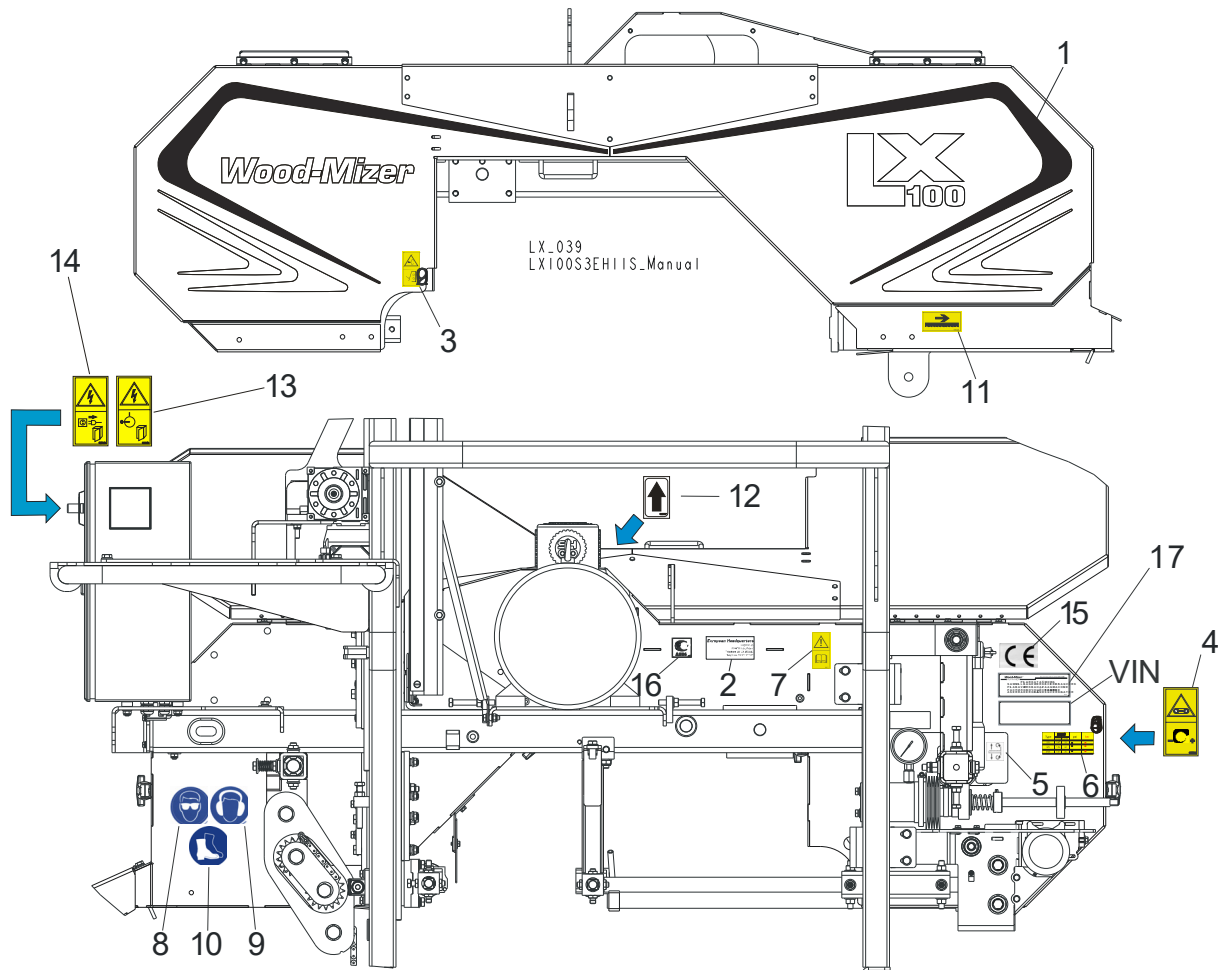

REF.	DESCRIPTION (◆ indicates parts available in assemblies only)	PART #	QTY
	<b>PICTOGRAPHIC DECAL KIT</b>	518619	1
1	DECAL, LX100 SERIES SAWMILL	565201	1
2	DECAL, EUROPEAN HEADQUARTERS ADDRESS	015841	1
3	DECAL, SAWMILL COVERS CAUTION	099220	1
4	DECAL, BLADE TENSION (PICTOGRAM)	099219	1
5	DECAL, BLADE ALIGNMENT	P11789	1
6	DECAL, TENSIONER PRESSURE VALUE	510643	1
7	DECAL, READ OPERATOR'S MANUAL (PICTOGRAM)	096317	1
8	DECAL, EYE WARNING (PICTOGRAM)	S12004G	1
9	DECAL, EAR WARNING (PICTOGRAM)	S12005G	1
10	DECAL, USE SAFETY BOOTS (PICTOGRAM)	501465	1
11	DECAL, BLADE MOVEMENT DIRECTION (PICTOGRAM)	096321	1
12	DECAL, MOTOR DIRECTION	S20097	1
13	DECAL, HIGH VOLTAGE IN ELECTRIC BOX	096316	1
14	DECAL, DISCONNECT POWER SUPPLY BEFORE OPENING	096319	1
15	<b>DECAL, CE CERTIFIED MACHINE [SMALL]</b>	P85070	1
16	<b>DECAL, RUSSIAN SAFETY CERTIFICATION</b>	099401	1
17	<b>DECAL, INTERNATIONAL SAWMILL NAME</b>	501466	1

**5.5 Belt Tensioner/Brake Assembly**

519110\_001  
519110\_MANUAL

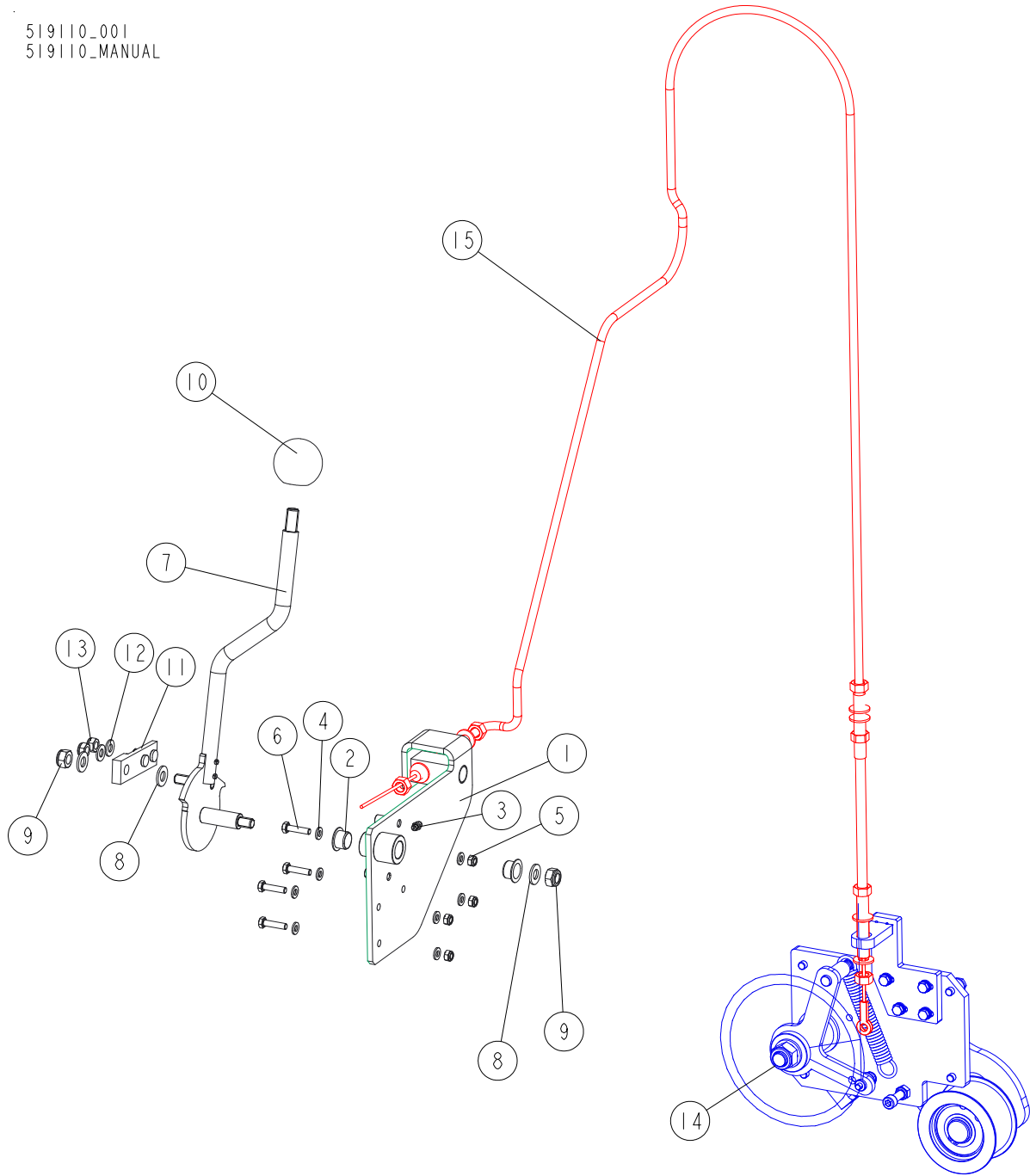

REF.	DESCRIPTION (◆ indicates parts available in assemblies only)	PART #	QTY
	<b>BELT TENSIONER/BRAKE ASSEMBLY</b>	<b>519110</b>	<b>1</b>
	<b>BRACKET, BELT TENSION/BRAKE LEVER - COMPLETE</b>	<b>519109</b>	<b>1</b>
1	BRACKET, BELT TENSION/BRAKE LEVER	519105-1	1
2	BUSHING, GFM-1618-12	091455	2
3	FITTING, M6 GREASE	086280	1
4	WASHER, 6.4 FLAT ZINC	F81053-1	8
5	NUT, M6-8-B HEX NYLON ZINC LOCK	F81031-2	4
6	BOLT, M6X25 5.8 HEX HEAD FULL THREAD ZINC	F81001-3	4

REF.	DESCRIPTION (◆ indicates parts available in assemblies only)	PART #	QTY	
	<b>LEVER, BELT TENSIONER/BRAKE - COMPLETE</b>	<b>519111</b>	<b>1</b>	
7	LEVER, BELT TENSIONER/BRAKE	519107-1	1	
8	WASHER, 10.5 FLAT ZINC	F81055-1	3	
9	NUT, M10-8-B HEX NYLON ZINC LOCK	F81033-1	2	
10	KNOB, DIN 319-KU-50-M12-C BALL	086337	1	
	<b>CLAMP, CABLE - COMPLETE</b>	<b>521455</b>	<b>1</b>	
11	CLAMP, CABLE	521460-1	1	
12	WASHER, 8.4 FLAT ZINC	F81054-1	2	
13	NUT, M8-8-B HEX NYLON ZINC LOCK	F81032-2	2	
14	ROLLER ASSEMBLY, BELT TENSION <a href="#">See Section 5.6</a>	519114	1	
	<b>CABLE, LX100 G25 BELT TENSION/BRAKE</b>	<b>518693</b>	<b>1</b>	
15	CABLE, LT15 G13/G15 THROTTLE	518693_BAZA	1	
16	CABLE 3	518693_BAZA_PR	1	
17	WASHER, 10.5 FLAT ZINC	F81055-1	6	
18	NUT, M10 8 HEX ZINC	F81033-3	6	

**5.6 Belt Tension Roller/Brake**

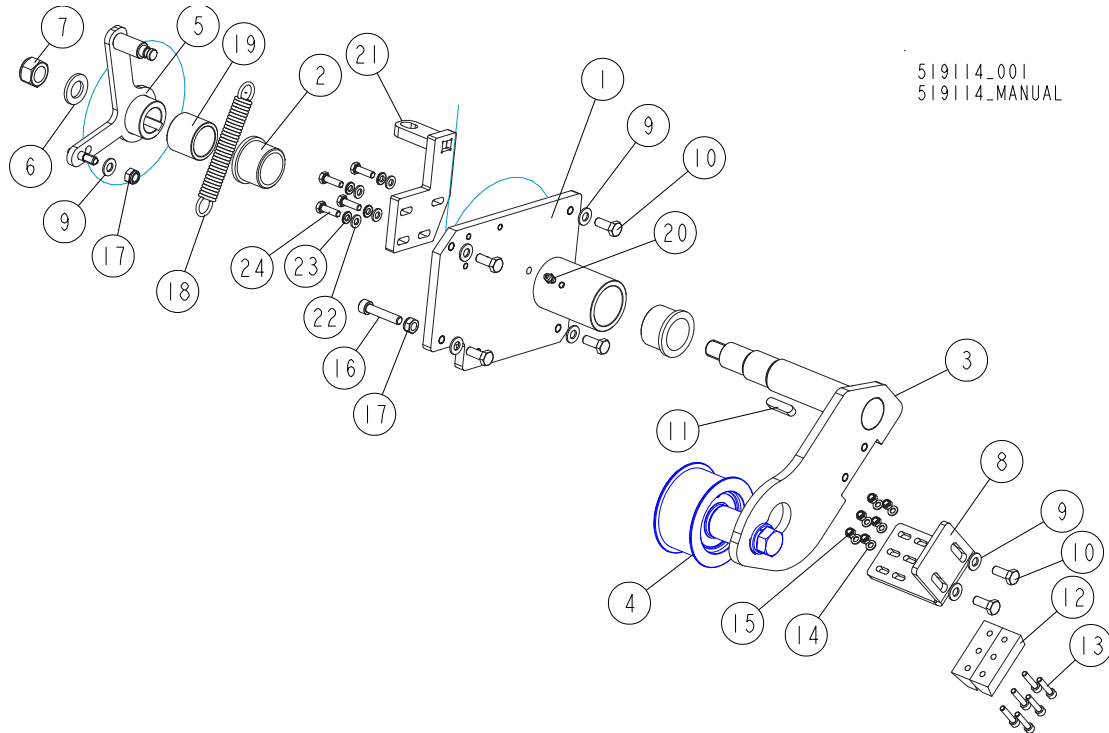

REF.	DESCRIPTION (◆ indicates parts available in assemblies only)	PART #	QTY
	<b>ROLLER ASSEMBLY, BELT TENSION</b>	<b>519114</b>	<b>1</b>
1	MOUNT WELDMENT, BELT TENSIONER	518687-1	1
2	BEARING, MFM-3240-30 (IGUS) SLEEVE	088461	2
3	SHAFT WELDMENT, BELT TENSIONER	096451-1	1
4	ROLLER, BELT TENSION - COMPLETE <a href="#">See Section 5.7</a>	511166	1
5	HANDLE WELDMENT, BELT TENSIONER	519522-1	1
6	WASHER, 17 SPLIT LOCK ZINC	F81058-1	1
7	NUT, M16-8 HEX NYLON ZINC LOCK	F81036-2	1
8	BRACKET, BRAKE BLOCK	091248-1	1
9	WASHER, 8.4 FLAT ZINC	F81054-1	7
10	BOLT, M8X20 8.8 HEX HEAD FULL THREAD ZINC	F81002-4	6
11	KEY, A8X7X32 PARALLEL	088564	1
12	PAD, BRAKE	092111	2
13	SCREW, M5X25 8.8 HEX SOCKET HEAD CAP ZINC	F81000-7	6
14	WASHER, 5.3 FLAT ZINC	F81052-1	6
15	NUT, M5-8 DIN985 HEX NYLON ZINC LOCK	F81030-2	6
16	SCREW, M8X40-8.8 HEX SOCKET HEAD CAP ZINC	F81002-29	1
17	NUT, M8-8-B HEX NYLON ZINC LOCK	F81032-2	2
18	SPRING, N1.9XN14.2X104	091865	1
19	BUSHING, TENSIONER ZINC-PLATED SPACER	097447-1	1
20	FITTING, M6 GREASE	086280	1
21	BRACKET WELDMENT, CABLE UPPER	519783-1	1
22	WASHER, 6.4 FLAT ZINC	F81053-1	4
23	WASHER, 6.1 DIN 127 (A2-304) STAINLESS STEEL SPRING	F81053-4	4
24	BOLT, M6X20 8.8 HEX HEAD FULL THREAD ZINC	F81001-2	4

## 5.7 Drive Belt Tension Roller

511166\_001  
 511166\_MANUAL

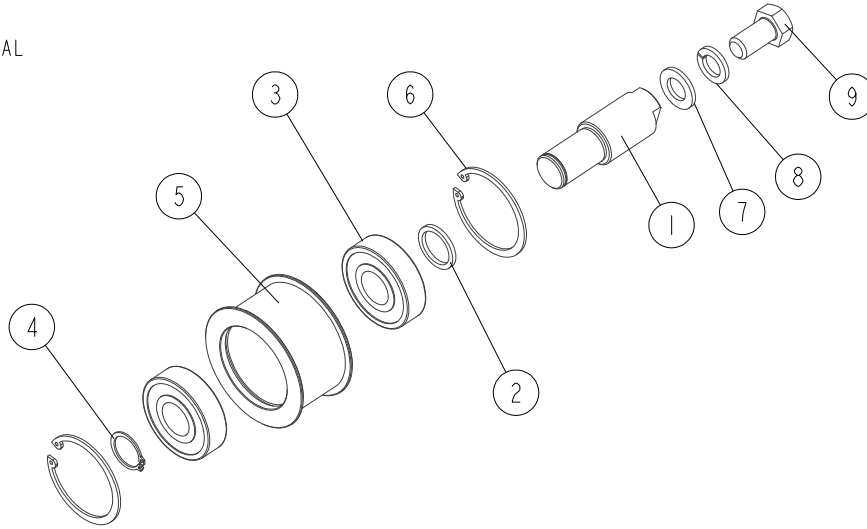

REF.	DESCRIPTION (◆ indicates parts available in assemblies only)	PART #	QTY
	<b>ROLLER, DRIVE BELT TENSION - COMPLETE</b>	<b>511166</b>	<b>1</b>
1	SHAFT, TENSION ROLLER	509901-1	1
2	WASHER, 25.1/32-3 ZINC-PLATED	500863-1	1
3	BEARING, 6305 DDUCM NSK	P08066	2
4	RING, 25Z OUTSIDE RETAINING	F81090-22	1
5	ROLLER, TENSION	087671-1	1
6	RING, 62W INSIDE RETAINING	F81090-1	2
7	WASHER, 17 SPLIT LOCK ZINC	F81058-1	1
8	WASHER, 16.3 SPLIT LOCK ZINC	F81058-2	1
9	BOLT, M16X30-8.8 HEX HEAD FULL THREAD ZINC	F81006-36	1

## SECTION 6 SAWMILL MAST

### 6.1 EH10S, Mast and Up/Down Limit Switches

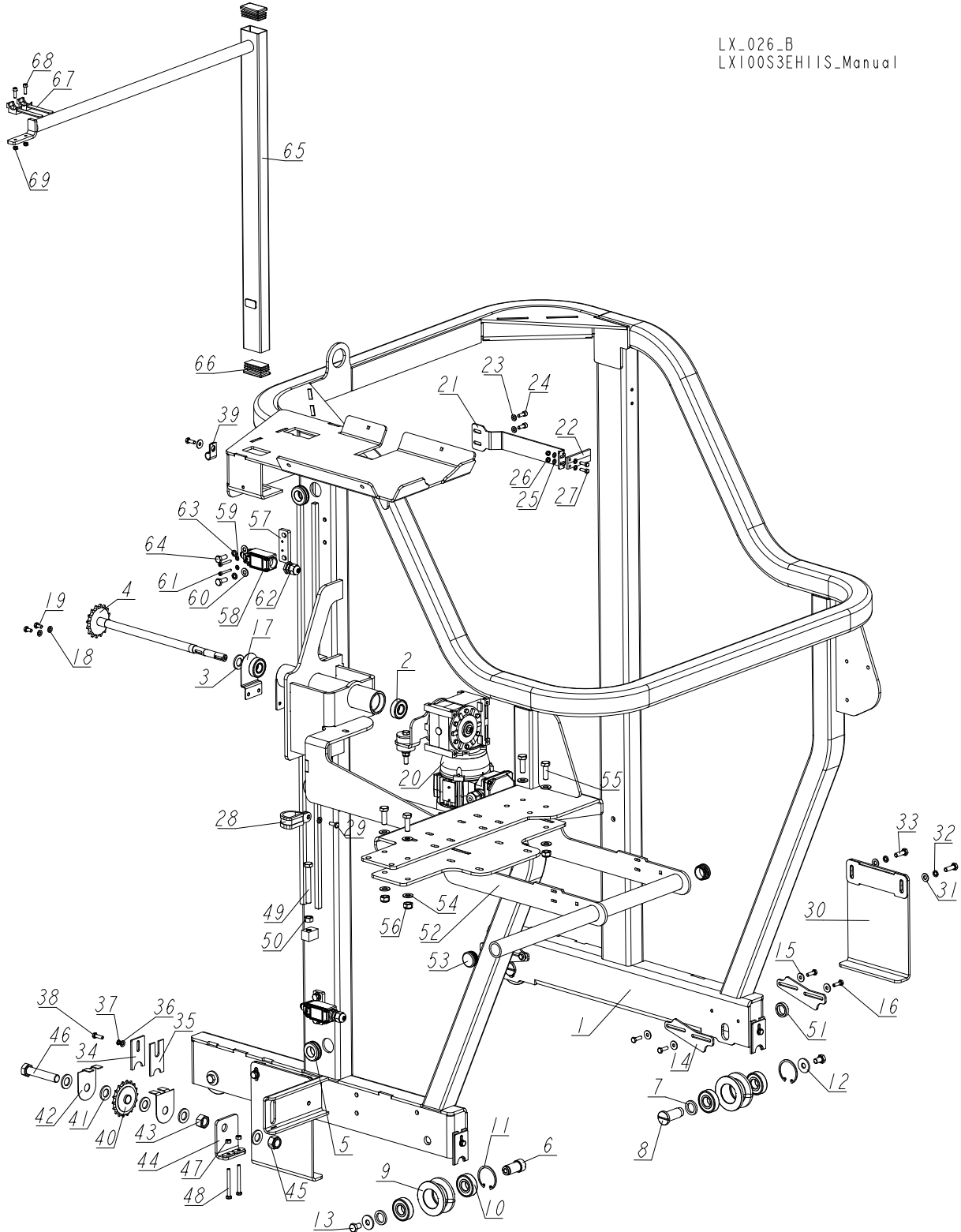

LX\_026\_B  
 LX100S3EH11S\_Manual



REF.	DESCRIPTION (◆ indicates parts available in assemblies only)	PART #	QTY
-	<b>MAST, CE AC - COMPLETE</b>	<b>516093</b>	<b>1</b>
-	<b>MAST</b>	<b>516092-1</b>	<b>1</b>
1	MAST WELDMENT	516091	1
2	BEARING, 6203-2RS FLT ROLLING	086114	2
3	WASHER, 17 FLAT ZINC	F81058-1	1
4	SHAFT WITH SPROCKET	513307	1
5	GROMMET, 22MM I.D. RUBBER	087400	3
6	PIN, FIXED TRACK ROLLER	515018	2
7	WASHER, 20.5X30-4 ZINC-PLATED	515021-1	4
8	PIN, ADJUSTABLE ROLLER	515101	2
-	<b>ROLLER ASSEMBLY, TRACK</b>	<b>515015</b>	<b>4</b>
9	ROLLER, TRACK	514889	1
10	BEARING, 6204 2RS CX ROLLING	088447	2
11	RING, W 47 INSIDE RETAINING	089653	1
12	WASHER, 11/30-3 ZINC-PLATED	088787-1	4
13	BOLT, M10X16-8.8 HEX HEAD FULL THREAD ZI	F81003-13	4
14	BAR, ROLLER ADJUSTMENT	520177-1	4
15	WASHER, 6.5 SPECIAL FLAT ZINC	F81053-11	9
16	BOLT, M6X20 8.8 HEX HEAD FULL THREAD ZIN	F81001-2	8
17	GUARD, UPPER LT10 SAW HEAD SPROCKET	092567	1
18	WASHER, 6.4 FLAT ZINC	F81053-1	3
19	BOLT, M6X12 8.8 HEX HEAD FULL THREAD ZIN	F81001-7	2
20	DRIVE ASSEMBLY, AC UP/DOWN <a href="#">See Section 8.1</a>	517395	1
-	<b>INDICATOR, BLADE HEIGHT SCALE - COMPLETE</b>	<b>517399</b>	<b>1</b>
21	INDICATOR, BLADE HEIGHT SCALE - COMPLETE	517382-1	1
22	TEFLON PLATE	094821	1
23	WASHER, 6.4 FLAT ZINC	F81053-1	2
24	SCREW, M6X16 8.8 HEX SOCKET HEAD CAP ZIN	F81001-21	2
25	WASHER 5,3 ZC DIN 126 ISO 7091	F81052-1	4
26	NUT, M5-8-FE/ZN5 DIN985	F81030-2	2
27	BOLT, M5 X 16-8.8 HEX HEAD FULL THREAD Z	F81000-20	2
28	CLAMP, RSGU 1.30/20	F81087-1	1
29	BOLT, M6X16-8.8 HEX HEAD FULL THREAD ZIN	F81001-15	2
-	<b>COMPLETE PLATE</b>	<b>517608</b>	<b>2</b>
30	PLATE, WELDMENT	517605-1	1
31	WASHER, 8.4 FLAT ZINC	F81054-1	2
32	WASHER, 8.2 SPLIT LOCK ZINC	F81054-4	2
33	BOLT, M8X25-8.8-B HEX HEAD FULL THREAD ZINC	F81002-5	2
-	<b>COMPLETE SCRAPER</b>	<b>517611</b>	<b>4</b>
34	PLATE, SCRAPER CLAMPING	517610-1	1
35	SCRAPER	517609	1
36	WASHER, 6.4 FLAT ZINC	F81053-1	1
37	WASHER, Z 6.1 SPLIT LOCK ZINC	F81053-3	1
38	BOLT, M6X20 8.8 HEX HEAD FULL THREAD ZIN	F81001-2	1
39	CLAMP, 1/2" EMT COATED	P07584	1
-	<b>SPROCKET ASSEMBLY, LOWER</b>	<b>518175</b>	<b>1</b>
40	SPROCKET, 40 IDLER 18T 5/8" ID	P04333	1

REF.	DESCRIPTION (◆ indicates parts available in assemblies only)	PART #	QTY
41	WASHER, 17 FLAT ZINC	F81058-1	5
42	GUARD,LT10 UP/DOWN CHAIN SPROCKET	092566-1	2
43	NUT, M16-8-HEX ZINC	F81036-1	1
44	TENSIONER, CHAIN	502524-1	1
45	NUT, M16 HEX NYLON ZINC LOCK	F81036-2	1
46	BOLT, M16X80 8.8-B HEX HEAD FULL THREAD	F81006-11	1
47	NUT, M6 8 HEX ZINC	F81031-1	2
48	BOLT, M6X60-8.8 HEX HEAD FULL THREAD ZINC	F81001-9	2
49	BOLT, M10X80 8.8 HEX HEAD FULL THREAD ZINC	F81003-76	1
50	NUT M10 ZC 8 DIN 934	F81033-3	1
51	BUSHING, N21XN30X7.2	503478-1	2
-	<b>HANDLE, LX100 - COMPLETE</b>	<b>555475</b>	<b>1</b>
52	HANDLE WELDMENT, LX100	555476-1	1
53	CAP, 1530 DIA. ROUND TUBE END (HOLE 30)	517616	2
54	WASHER, 10.5 FLAT ZINC	F81055-1	8
55	BOLT, M10X30-8.8 HEX HEAD FULL THREAD ZI	F81003-2	4
56	NUT, M10-8-B HEX NYLON ZINC LOCK	F81033-1	4
-	<b>EVN2000C LIMIT SWITCH W/MOUNT PLATE</b>	<b>094227</b>	<b>2</b>
57	PLATE, LIMIT SWITCH MOUNT	094228-1	1
58	SWITCH, FA134 Z11 SAFETY	100910	1
59	WASHER, 4.3 FLAT ZINC	F81051-2	2
60	WASHER, 8.4 FLAT ZINC	F81054-1	2
61	SCREW, M4X30-8.8 DIN 912 ISO 4762 HEX S	F81000-85	2
62	GLAND, DP9/H CABLE	F81096-2	1
63	WASHER, 8.2 SPLIT LOCK ZINC	F81054-4	2
64	BOLT, M8X20-8.8-B HEX HEAD FULL THREAD Z	F81002-4	2
-	<b>BRACKET, LT15 POWER CORD COMPLETE</b>	<b>097449</b>	<b>1</b>
65	BRACKET, LT15 POWER CORD PAINTED	086132-1	1
66	CAP, 50X30 BLACK	095919	2
67	HOLDER, CABLE PLASTIC TIE	F81082-1	2
68	BOLT M5X16 SHCS ZC PT 8.8 DIN 912 ISO 47	F81000-25	2
69	NUT, M5-8-FE/ZN5 DIN985	F81030-2	2

## 6.2 Handle for Manual Feed

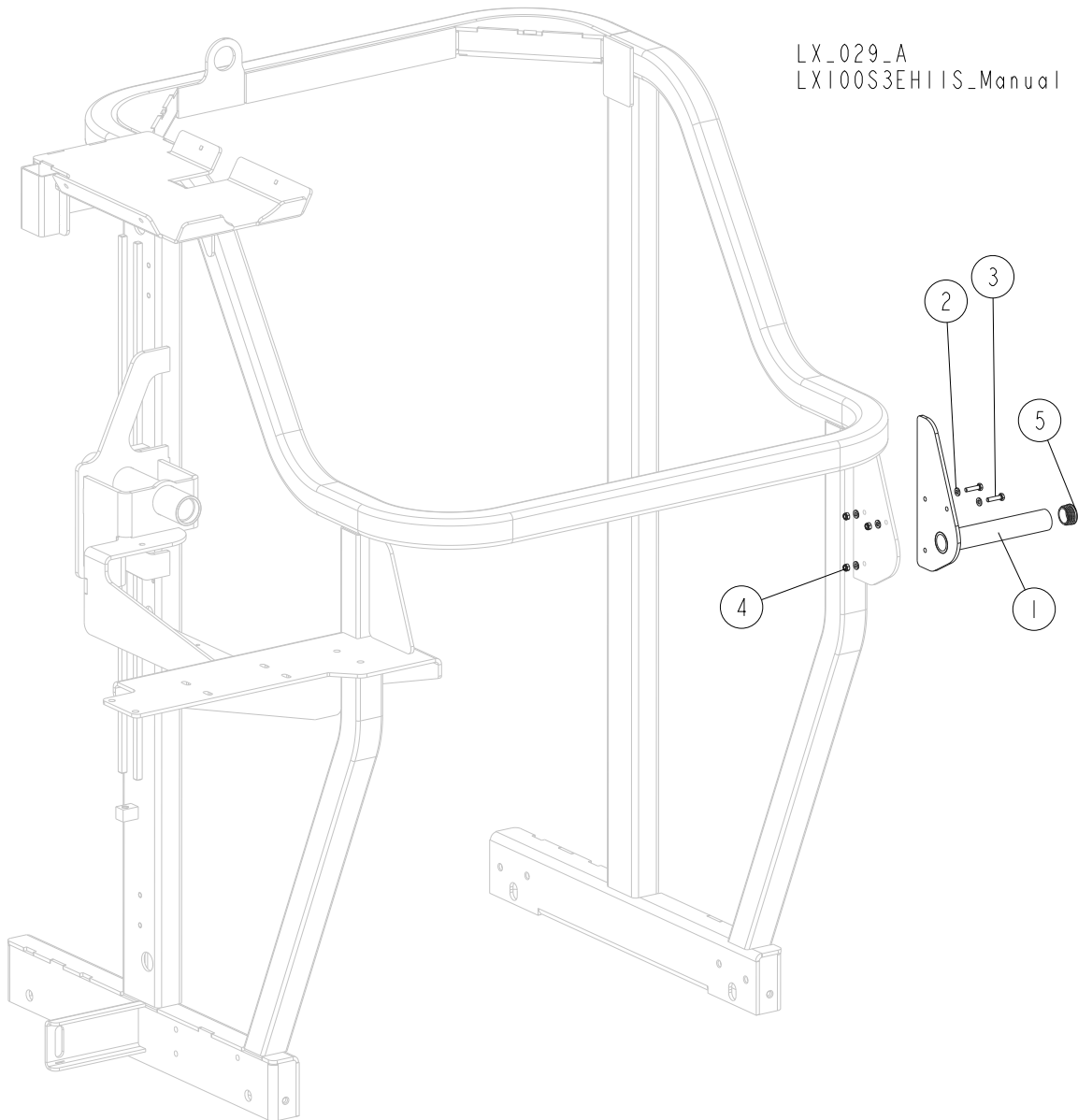

REF.	DESCRIPTION (◆ indicates parts available in assemblies only)	PART #	QTY
	<b>HANDLE, ADDITIONAL - COMPLETE</b>	<b>516821</b>	<b>1</b>
1	HANDLE WELDMENT	516820-1	1
2	WASHER, 6.4 FLAT ZINC	F81053-1	6
3	BOLT, M6X25 5.8 HEX HEAD FULL THREAD ZINC	F81001-3	3
4	NUT, M6-8-B HEX NYLON ZINC LOCK	F81031-2	3
5	CAP, SR1530 (30 HOLE) TUBE	517616	1

# 6 SAWMILL MAST

## E15 Sawmill Mast (African Version)

### 6.3 E15 Sawmill Mast (African Version)

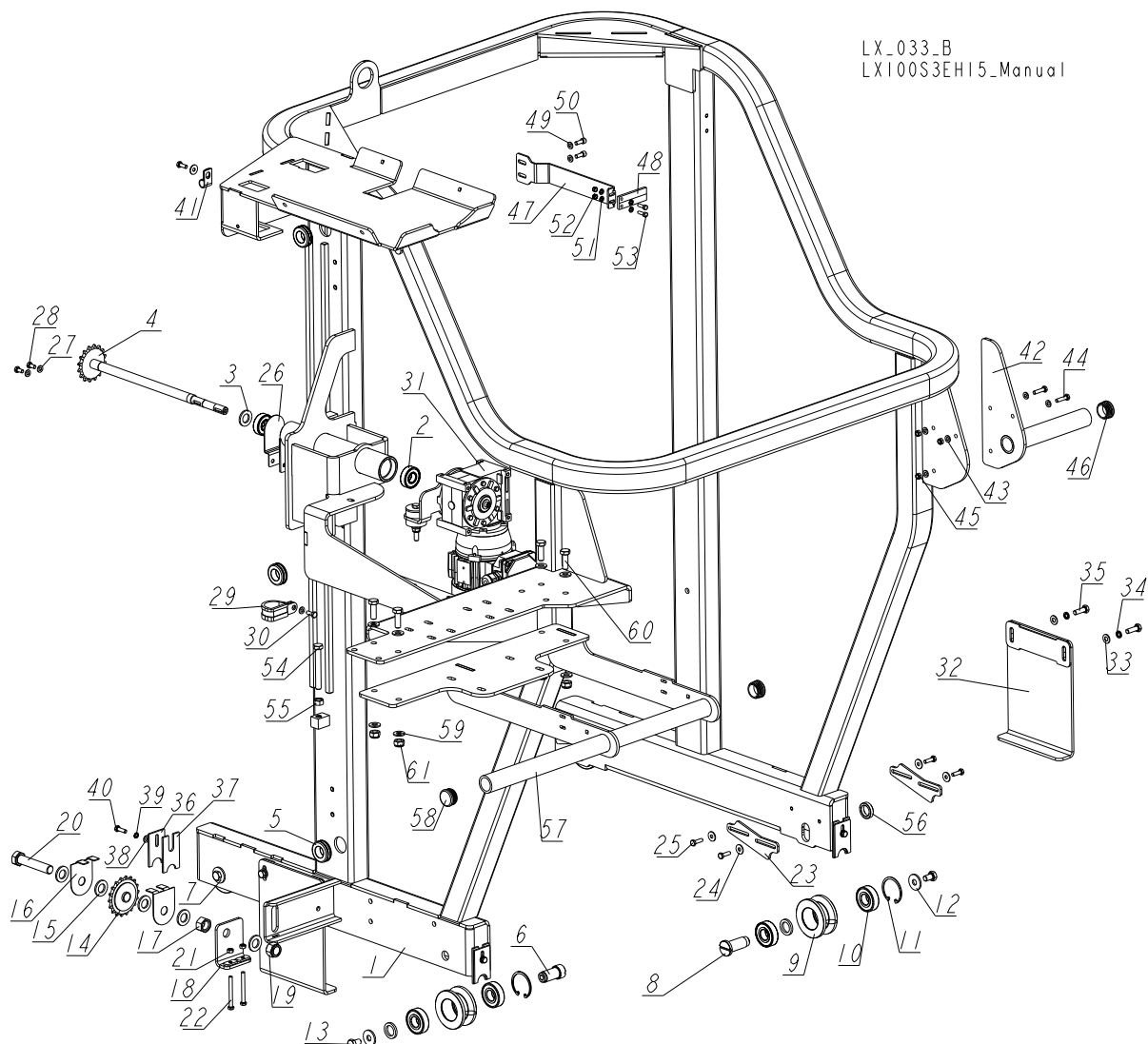

LX\_033\_B  
LX100S3EH15\_Manual

REF.	DESCRIPTION (◆ indicates parts available in assemblies only)	PART #	QTY
-	<b>MAST, COMPLETE</b>	<b>517385</b>	<b>1</b>
-	<b>MAST</b>	<b>516092-1</b>	<b>1</b>
1	MAST WELDMENT	516091	1
2	BEARING, 6203-2RS FLT ROLLING	086114	2
3	WASHER, 17 FLAT ZINC	F81058-1	1
4	SHAFT WITH SPROCKET	513307	1
5	GROMMET, 22MM I.D. RUBBER	087400	3
6	PIN, FIXED TRACK ROLLER	515018	2
7	WASHER, 20.5X30-4 ZINC-PLATED	515021-1	4
8	PIN, ADJUSTABLE ROLLER	515101	2
-	<b>ROLLER ASSEMBLY, TRACK</b>	<b>515015</b>	<b>4</b>
9	ROLLER, TRACK	514889	1
10	BEARING, 6204 2RS CX ROLLING	088447	2

REF.	DESCRIPTION (◆ indicates parts available in assemblies only)	PART #	QTY
11	RING, W 47 INSIDE RETAINING	089653	1
12	WASHER, 11/30-3 ZINC-PLATED	088787-1	4
13	BOLT, M10X16-8.8 HEX HEAD FULL THREAD ZINC	F81003-13	4
-	<b>SPROCKET ASSEMBLY, LOWER</b>	<b>518175</b>	<b>1</b>
14	SPROCKET, 40 IDLER 18T 5/8" ID	P04333	1
15	WASHER, 17 FLAT ZINC	F81058-1	5
16	GUARD, LT10 UP/DOWN CHAIN SPROCKET	092566-1	2
17	NUT, M16-8-HEX ZINC	F81036-1	1
18	TENSIONER, CHAIN	502524-1	1
19	NUT, M16 HEX NYLON ZINC LOCK	F81036-2	1
20	BOLT, M16X80 8.8-B HEX HEAD FULL THREAD	F81006-11	1
21	NUT, M6 8 HEX ZINC	F81031-1	2
22	BOLT, M6X60-8.8 HEX HEAD FULL THREAD ZIN	F81001-9	2
23	BAR, ROLLER ADJUSTMENT	520177-1	4
24	WASHER, 6.5 SPECIAL FLAT ZINC	F81053-11	9
25	BOLT, M6X20 8.8 HEX HEAD FULL THREAD ZIN	F81001-2	8
26	GUARD, UPPER LT10 SAW HEAD SPROCKET	092567	1
27	WASHER, 6.4 FLAT ZINC	F81053-1	3
28	BOLT, M6X12 8.8 HEX HEAD FULL THREAD ZIN	F81001-7	2
29	CLAMP, RSGU 1.30/20	F81087-1	1
30	BOLT, M6X16-8.8 HEX HEAD FULL THREAD ZIN	F81001-15	2
31	DRIVE ASSEMBLY, AC UP/DOWN <a href="#">See Section 8.1</a>	517395	1
-	<b>COMPLETE PLATE</b>	<b>517608</b>	<b>2</b>
32	PLATE, WELDMENT/ PŁYTA SPAW./MALOW.	517605-1	1
33	WASHER, 8.4 FLAT ZINC	F81054-1	2
34	WASHER, 8.2 SPLIT LOCK ZINC	F81054-4	2
35	BOLT, M8X25-8.8-B HEX HEAD FULL THREAD ZI	F81002-5	2
-	<b>COMPLETE SCRAPER</b>	<b>517611</b>	<b>4</b>
36	PLATE, SCRAPER CLAMPING	517610-1	1
37	SCRAPER	517609	1
38	WASHER, 6.4 FLAT ZINC	F81053-1	1
39	WASHER, Z 6.1 SPLIT LOCK ZINC	F81053-3	1
40	BOLT, M6X20 8.8 HEX HEAD FULL THREAD ZIN	F81001-2	1
41	CLAMP, 1/2" EMT COATED	P07584	1
-	<b>HANDLE, ADDITIONAL - COMPLETE</b>	<b>516821</b>	<b>1</b>
42	HANDLE WELDMENT	516820-1	1
43	WASHER, 6.4 FLAT ZINC	F81053-1	6
44	BOLT, M6X25 -8.8 HEX HEAD FULL THREAD ZI	F81001-3	3
45	NUT, M6-8-B HEX NYLON ZINC LOCK	F81031-2	3
46	CAP, 1530 DIA. ROUND TUBE END (HOLE 30)	517616	1
-	<b>INDICATOR, BLADE HEIGHT SCALE - COMPLETE</b>	<b>517399</b>	<b>1</b>
47	INDICATOR, BLADE HEIGHT SCALE - COMPLETE	517382-1	1
48	TEFLON PLATE	094821	1
49	WASHER, 6.4 FLAT ZINC	F81053-1	2
50	SCREW, M6X16 8.8 HEX SOCKET HEAD CAP ZIN	F81001-21	2
51	WASHER 5,3 ZC DIN 126 ISO 7091	F81052-1	4
52	NUT, M5-8-FE/ZN5 DIN985	F81030-2	2

**SAWMILL MAST***E15 Sawmill Mast (African Version)*

REF.	DESCRIPTION (◆ indicates parts available in assemblies only)	PART #	QTY	
53	BOLT, M5 X 16-8.8 HEX HEAD FULL THREAD ZINC	F81000-20	2	
54	BOLT, M10X80 8.8 HEX HEAD FULL THREAD ZINC	F81003-76	1	
55	NUT M10 ZC 8 DIN 934	F81033-3	1	
56	BUSHING, N21XN30X7.2	503478-1	2	
-	<b>HANDLE, LX100 - COMPLETE</b>	<b>555475</b>	<b>1</b>	
57	HANDLE WELDMENT, LX100	555476-1	1	
58	CAP, 1530 DIA. ROUND TUBE END (HOLE 30)	517616	2	
59	WASHER, 10.5 FLAT ZINC	F81055-1	8	
60	BOLT, M10X30-8.8 HEX HEAD FULL THREAD ZI	F81003-2	4	
61	NUT, M10-8-B HEX NYLON ZINC LOCK	F81033-1	4	

**6.4 EC Mast**

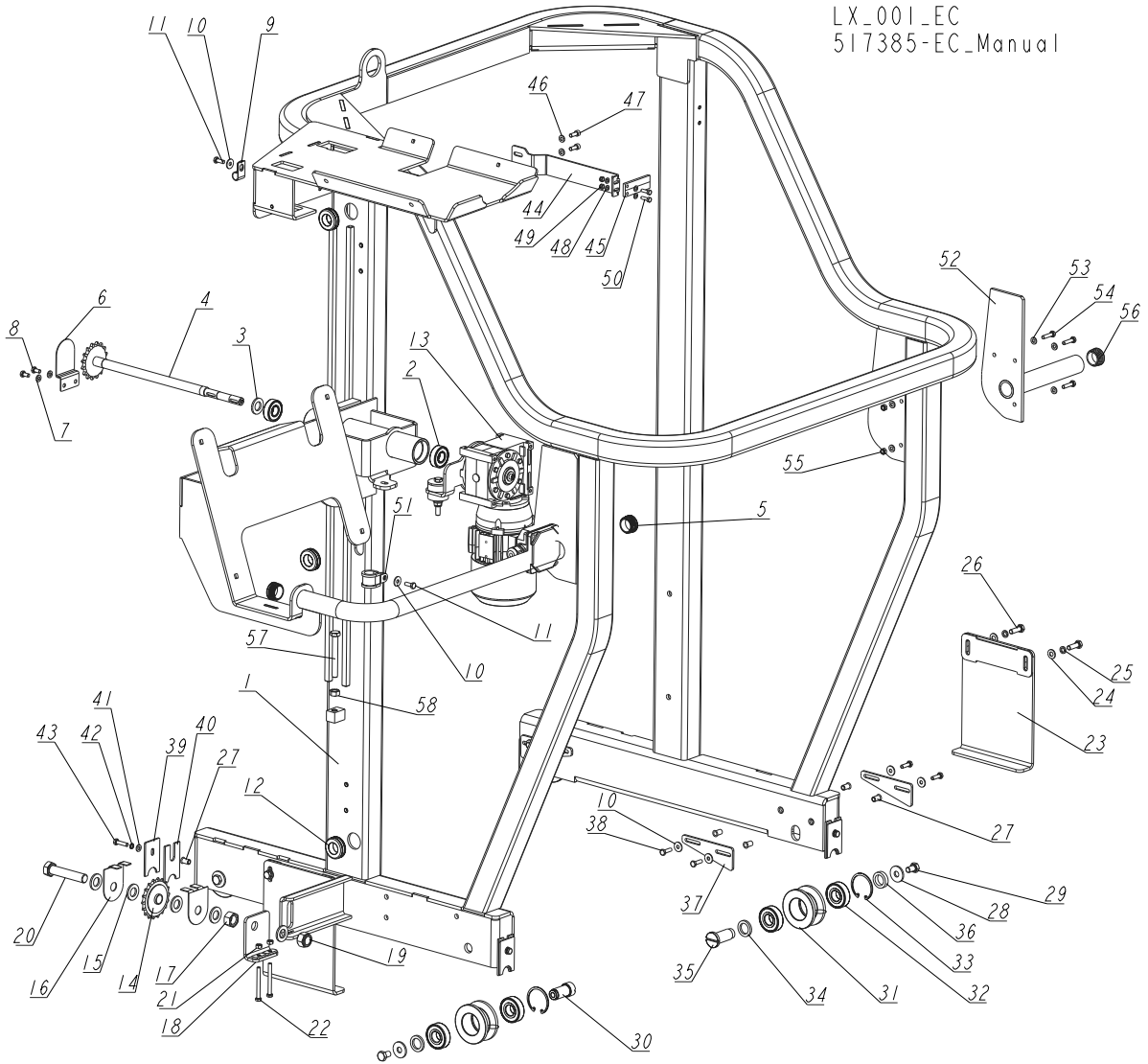

REF	DESCRIPTION (* Indicates Parts Available In Assemblies Only)	PART #	QTY
	<b>MAST, LX100 EC - COMPLETE</b>	<b>517385-EC</b>	<b>1</b>
	<b>MAST, LX100 EC</b>	<b>517386-1EC</b>	<b>1</b>
1	MAST WELDMENT, LX100 EC	517387-EC	1
2	BEARING, 6203-2RS	086114	2
3	WASHER, 17 FLAT ZINC	F81058-1	1
4	SHAFT WITH SPROCKET	513307	1
5	CAP, SR1530 (30 HOLE) TUBE	517616	2
6	GUARD, LT15 UPPER SAW HEAD SPROCKET	092567-1	1
7	WASHER, 6.5 SPECIAL FLAT ZINC	F81053-1	2
8	BOLT, M6X12-8.8 HEX HEAD FULL THREAD ZINC	F81001-7	2
9	CLAMP, 1/2EMT COATED	P07584	1
10	WASHER, 6.5 SPECIAL FLAT ZINC	F81053-11	10
11	BOLT, M6 X 16 8.8 HEX HEAD FULL THREAD ZINC	F81001-15	2
12	GROMMET, 22 MM ID RUBBER	087400	3

REF	DESCRIPTION (* Indicates Parts Available In Assemblies Only)	PART #	QTY
13	DRIVE ASSEMBLY, UP/DOWN <a href="#">See Section 8.1</a>	517395	1
	<b>SPROCKET ASSEMBLY, BOTTOM</b>	<b>518175</b>	<b>1</b>
14	SPROCKET, #40 IDLER 17T 5/8ID	P04333	1
15	WASHER, 17 FLAT ZINC	F81058-1	5
16	GUARD, LT15 UP/DOWN CHAIN SPROCKET	092566-1	2
17	NUT, M16-5.8 HEX ZINC	F81036-1	1
18	TENSIONER, CHAIN	502524-1	1
19	NUT, M16-8 HEX NYLON ZINC LOCK	F81036-2	1
20	BOLT, M16X80 8.8-B HEX HEAD FULL THREAD ZINC	F81006-11	1
21	NUT, M6-8 HEX ZINC	F81031-1	2
22	BOLT, M6X60-8.8 HEX HEAD FULL THREAD ZINNC	F81001-9	2
	<b>COMPLETE PLATE</b>	<b>517608</b>	<b>2</b>
23	PLATE WELDMENT	517605-1	1
24	WASHER, 8.4 FLAT ZINC	F81054-1	2
25	WASHER 8.2 SPLIT LOCK ZINC	F81054-4	2
26	BOLT, M8X25-8.8-B HEX HEAD FULL THREAD ZINC	F81002-5	2
27	NUT, M6 1.5-4.0 STAINLESS STEEL RIVET	F81031-9	12
28	WASHER, 11 SPECIAL FLAT ZINC	088787-1	4
29	BOLT, M10X16-8.8 HEX HEAD FULL THREAD ZINC	F81003-13	4
30	PIN, FIXED TRACK ROLLER	515018	2
	<b>ROLLER ASSEMBLY, TRACK</b>	<b>515015</b>	<b>4</b>
31	ROLLER	514889	1
32	BEARING, 6204 2RS-CX ROLLING	088447	2
33	RING, W47 INSIDE RETAINING	089653	1
34	WASHER, 20.5X30-4, ZINCK	515021-1	4
35	PIN, ADJUSTABLE ROLLER	515101	2
36	BUSHING, N21XN30X7.2	503478-1	2
37	PLATE, ROLLER ADJUSTMENT	516508-1	4
38	BOLT, M6X20-8.8 HEX HEAD FULL THREAD ZINC	F81001-2	8
	<b>COMPLETE SCRAPER</b>	<b>517611</b>	<b>4</b>
39	PLATE, SCRAPER CLAMPING	517610-1	1
40	SCRAPER	517609	1
41	WASHER, 6.4 FLAT ZINC	F81053-1	1
42	WASHER, Z 6.1 SPLIT LOCK ZINC	F81053-3	1
43	BOLT, M6x25 -5.8 HEX HEAD FULL THREAD ZINC	F81001-3	1
	<b>INDICATOR, BLADE HEIGHT SCALE - COMPLETE</b>	<b>517399</b>	<b>1</b>
44	INDICATOR, BLADE HEIGHT SCALE - COMPLETE	517382-1	1
45	INDICATOR, BLADE HEIGHT SCALE	094821	1
46	WASHER, 6.4 FLAT ZINC	F81053-1	2
47	SCREW, M6X16 HEX SOCKET HEAD CAP	F81001-21	2
48	WASHER, 5.3 FLAT ZINC	F81052-1	4
49	NUT, M5-8-FE/ZN5 DIN985	F81030-2	2
50	BOLT, M5X16-8.8 HEX HEAD FULL THREAD ZINC	F81000-20	2
51	CLIP, RSGU 1.30/20 RETAINING	F81087-1	1
	<b>HANDLE, EC, COMPLETE</b>	<b>519919</b>	<b>1</b>
52	HANDLE EC WELDMENT	519918-1	1
53	WASHER, 6.5 SPECIAL FLAT ZINC	F81053-1	6



---

<b>REF</b>	<b>DESCRIPTION (* Indicates Parts Available In Assemblies Only)</b>	<b>PART #</b>	<b>QTY</b>	
<b>54</b>	BOLT, M6x25 -5.8 HEX HEAD FULL THREAD ZINC	F81001-3	3	
<b>55</b>	NUT, M6-8-B HEX NYLON ZINC LOCK	F81031-2	3	
<b>56</b>	CAP, SR1530 (30 HOLE) TUBE	517616	1	
<b>57</b>	BOLT, M10-80-8.8 HEX HEAD FULL THREAD ZINC	F81003-76	1	
<b>58</b>	NUT, M10-8-B HEX ZINC	F81033-3	1	

## SECTION 7 POWER FEED SYSTEM

### 7.1 AC Power Feed Assembly

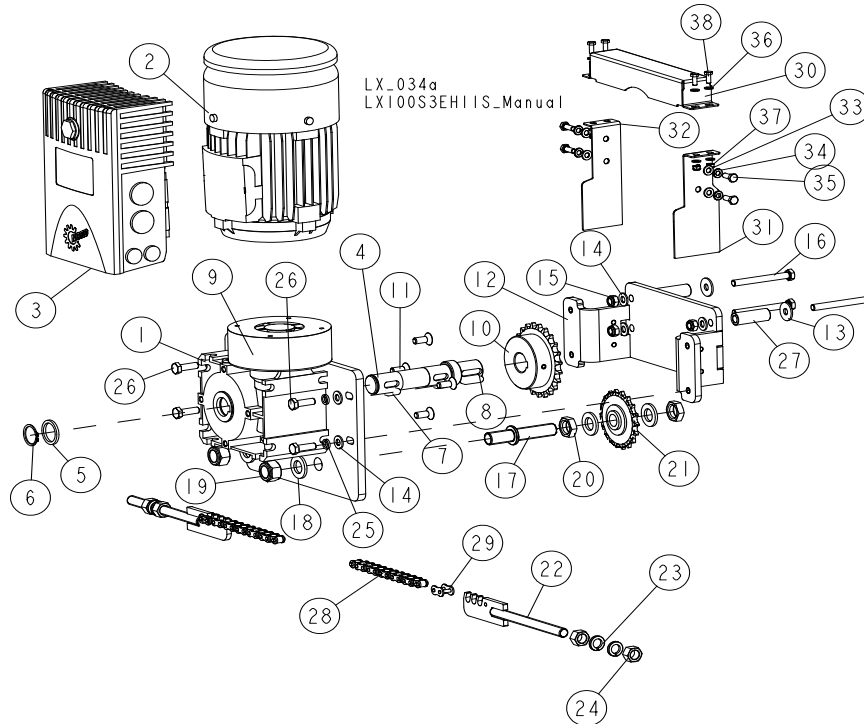

REF.	DESCRIPTION (* Indicates Parts Available In Assemblies Only)	PART #	QTY
	<b>S3/AC-P POWER FEED EQUIPMENT</b>	<b>517910-S3M2</b>	<b>1</b>
	<b>S4/AC-P POWER FEED EQUIPMENT</b>	<b>517910-S4</b>	<b>1</b>
	<b>S5/AC-P POWER FEED EQUIPMENT</b>	<b>517910-S5</b>	<b>1</b>
	<b>M3/AC-P POWER FEED EQUIPMENT</b>	<b>517910-M3</b>	<b>1</b>
	<b>M4/AC-P POWER FEED EQUIPMENT</b>	<b>517910-M4</b>	<b>1</b>
	<b>M5/AC-P POWER FEED EQUIPMENT</b>	<b>517910-M5</b>	<b>1</b>
-	DRIVE ASSEMBLY, LX 100 - AC POWER FEED	517885	1
-	KIT, SK1SI50-IEC80-80LH/4 TF RD 180E + SK 180E-750-340-B	538654	1
-	MOTOREDUCER, SK1SI50-IEC80-80LH/4 TF RD 180E	536452	1
1	GEARBOX, SK1SI50-IEC80-80LH/4 TF RD 180E	538709	1
2	MOTOR, SK1SI50-IEC80-80LH/4 TF RD 180E	538710	1
3	INVERTER, SK 180E-750-340-B FREQUENCY	538539	1
4	SHAFT, OUTPUT	550428	1
5	WASHER, 25.1/32-3 ZINC-PLATED	500863-1	1
6	RING, 25Z OUTSIDE RETAINING	F81090-22	1
7	KEY, A8X7X20 PARALLEL	099059	2
8	KEY, A8X7X28 PARALLEL	096035	1
9	PLATE, GEARBOX MOUNT	550433-1	1
10	SPROCKET, 08B-1; Z=23;DP=93.27(T 72548)	517883-1	1
11	SCREW, M8X20-8.8 DIN7991 HEX SOCKET COUNTERSUNK HEAD ZINC	F81002-70	4
12	BRACKET, MOUNT	517886-1	1
13	WASHER, ISO 7093-1-8-200 HV-A2E.	F81054-11	3

REF.	DESCRIPTION (* Indicates Parts Available In Assemblies Only)	PART #	QTY	
14	WASHER, 8.4 FLAT ZINC	F81054-1	7	
15	NUT, M8-8-B HEX NYLON ZINC LOCK	F81032-2	3	
16	BOLT, M8X75-8.8 HEX HEAD ZINC	F81002-91	3	
-	SPROCKET ASSEMBLY	517890	2	
17	SHAFT, SPROCKET	517891-1	1	
18	WASHER, 17 SPLIT LOCK ZINC	F81058-1	3	
19	NUT, M16-8 HEX NYLON ZINC LOCK	F81036-2	1	
20	NUT, M16 FE/ZN5 8 THIN ZINC	F81036-4	2	
21	SPROCKET, Z=18 KSR16.L0.08.10.18.09	088700	1	
22	BRACKET, POWER FEED CHAIN	517895-1	2	
23	WASHER, Z12.2 SPLIT LOCK ZINC	F81056-2	4	
24	NUT, M12-8-B HEX ZINC	F81034-1	4	
25	WASHER, 8.2 SPLIT LOCK ZINC	F81054-4	4	
26	BOLT, M8X25-8.8-B HEX HEAD FULL THREAD ZINC	F81002-5	4	
27	BUSHING, 9/16-44.5 ZINC-PLATED	517914-1	3	
28	CHAIN, 08B; LENGTH=6.72 M (529-LINK)	517898-S3M2	1	
29	LINK, 08B-1PZ CHAIN	091625	2	
-	GUARD ASSEMBLY, POWER FEED DRIVE	517915	1	
30	GUARD, TOP	517912-1	1	
31	PLATE, RIGHT SIDE	517906-1	1	
32	PLATE, LEFT SIDE	517909-1	1	
33	WASHER, 6.4 FLAT ZINC	F81053-1	4	
34	WASHER, 6.1 DIN 127 (A2-304) STAINLESS STEEL SPRING	F81053-4	4	
35	BOLT, M6X16-8.8 HEX HEAD FULL THREAD ZINC	F81001-15	4	
36	WASHER, 5.3 FLAT ZINC	F81052-1	8	
37	NUT, M5-8 DIN985 HEX NYLON ZINC LOCK	F81030-2	4	
38	BOLT, M5 X 12 8.8 HEX HEAD FULL THREAD ZINC	F81000-5	4	

**7.2 Power Feed Guard Assembly**

LX\_035  
 LX100S3EH11S\_Manual

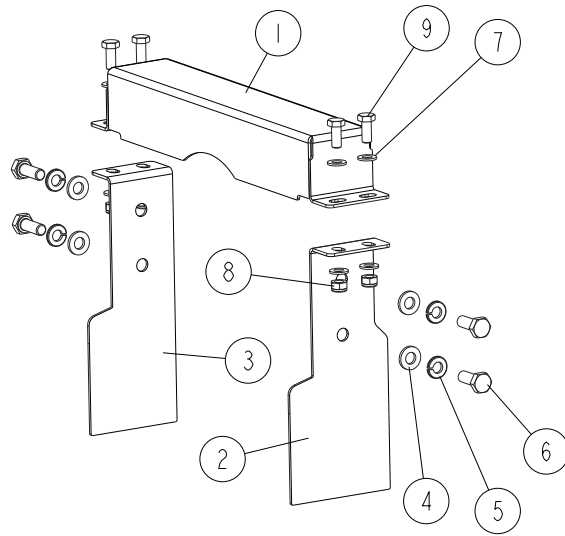

REF.	DESCRIPTION (◆ indicates parts available in assemblies only)	PART #	QTY
	<b>GUARD ASSEMBLY, POWER FEED</b>	<b>517915</b>	<b>1</b>
1	GUARD, TOP	517912-1	1
2	PLATE, RIGHT SIDE	517906-1	1
3	PLATE, LEFT SIDE	517909-1	1
4	WASHER, 6.4 FLAT ZINC	F81053-1	4
5	WASHER, 6.1 DIN 127 (A2-304) SPLIT LOCK	F81053-4	4
6	BOLT, M6 X 16 8.8 HEX HEAD FULL THREAD ZINC	F81001-15	4
7	WASHER, 5.3 FLAT ZINC	F81052-1	8
8	NUT, M5-8 DIN985 HEX NYLON ZINC LOCK	F81030-2	4
9	BOLT, M5 X 12-5.8 HEX HEAD FULL THREAD ZINC	F81000-5	4

## 7.3 Power Feed 597521

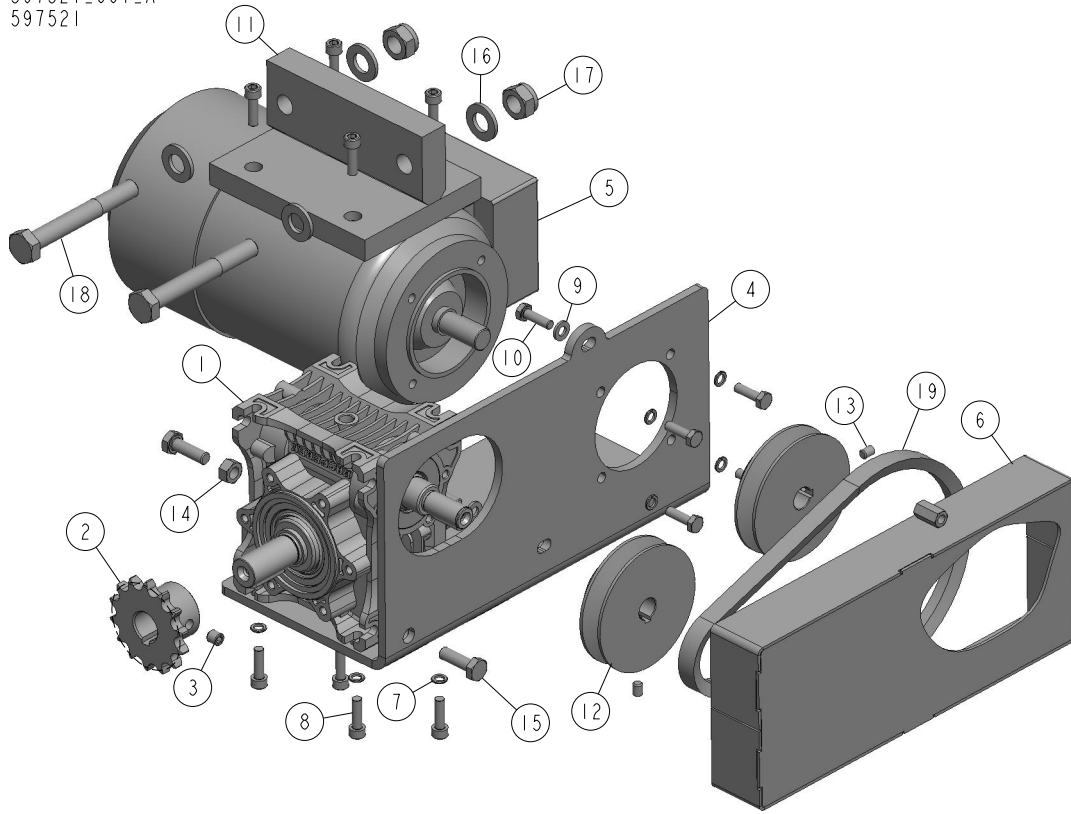
597521\_001\_A  
597521

REF	DESCRIPTION (◆ indicates parts available in assemblies only)	PART #	QTY
-	POWER FEED DRIVE, LT20 AC	597521	1
1	MRA-04/7,5-WBS-WJ/1-N/S-B8	597515	1
2	SPROCKET, 08B Z14 ZINC-PLATED	090702-1	1
3	SCREW, M8X8-33H HEX SOCKET SET FLAT POIN	F81014-1	1
4	PLATE, POWER FEED REDUCER MOUNTING LT20	597520-1	1
5	MOTOR, KH71X-2C2, RAL 9005	097313	1
6	GUARD, POWER FEED DRIVE BELT	091195-1	1
7	WASHER, Z 6.1 SPLIT LOCK ZINC	F81053-3	8
8	SCREW, M6X20 8.8 HEX SOCKET HEAD CAP ZIN	F81001-22	8
9	WASHER, 6.4 FLAT ZINC	F81053-1	2
10	BOLT, M6X20-8.8 HEX HEAD FULL THREAD ZIN	F81001-2	6
11	BRACKET, POWER FEED REDUCER LT20	597518-1	1
12	PULLEY, LT20 POWER FEED GEAR BOX	090699-1	2
13	SCREW, M6X8 HEX SOCKET SET CONE POINT ZI	F81013-1	2
14	NUT, M8-8-B HEX ZINC	F81032-1	2
15	BOLT, M8X25-8.8-B HEX HEAD FULL THREAD Z	F81002-5	2
16	WASHER, 13 FLAT ZINC	F81056-1	4
17	NUT, M12 8 HEX NYLON ZINC LOCK	F81034-2	2
18	BOLT, M12X90 8.8 HEX HEAD ZINC	F81004-2	2
19	V-BELT, HA-560 (STOMIL-SANOK)	088562	1

## 7.4 Power Feed Assembly 597521-7

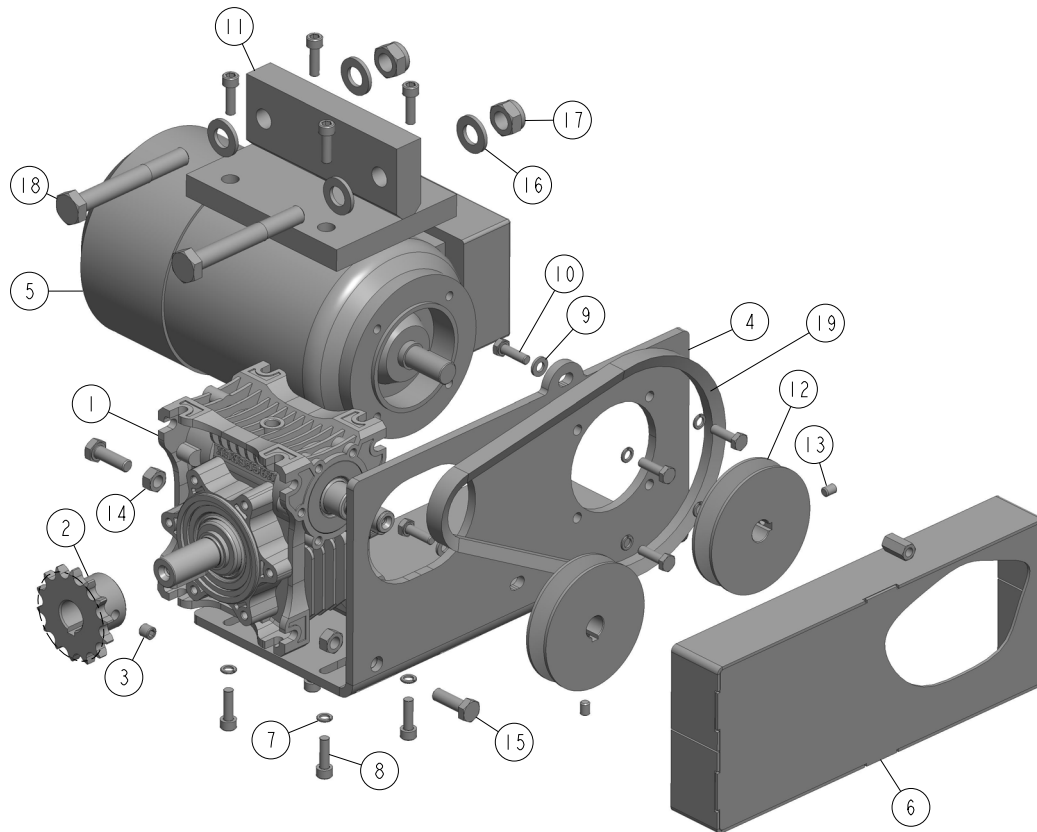
597521-7\_001\_A  
597521-7

REF	DESCRIPTION (◆ indicates parts available in assemblies only)	PART #	QTY
-	<b>POWER FEED ASSEMBLY, LT20 AC JAP.</b>	597521-7	1
1	GEAR BOX, MRA-04/7,5-WBS-WJ/1-N/S-B8	597515	1
2	SPROCKET, 08B Z14 ZINC-PLATED	090702-1	1
3	SCREW, M8 X 8-33H	F81014-1	1
4	BLACHA UCHWYTOWA REDUKTORA P/T LT20 AC MAL.	597520-1	1
5	MOTOR SKH71X-2C2; 0.75KW; 2780R/MIN.	097313-7	1
6	GUARD, POWER FEED DRIVE BELT	091195-1	1
7	WASHER, Z 6.1 SPLIT LOCK ZINC	F81053-3	8
8	SCREW, M6X20 8.8 HEX SOCKET HEAD CAP ZIN	F81001-22	8
9	WASHER, 6.4 FLAT ZINC	F81053-1	2
10	BOLT, M6X20-8.8 HEX HEAD FULL THREAD ZIN	F81001-2	6
11	BRACKET, POWER FEED GEAR BOX MOUNT	597518-1	1
12	PULLEY, LT20 POWER FEED GEAR BOX	090699-1	2
13	SCREW, M6 X 8 BLACK OXIDE SOCKET HEAD SE	F81013-1	2
14	NUT, M8-8-B HEX ZINC	F81032-1	2
15	BOLT, M8X25-8.8-B-HEX HEAD FULL THREAD Z	F81002-5	2
16	WASHER, 13 FLAT ZINC	F81056-1	4
17	NUT, M12 8 HEX NYLON ZINC LOCK	F81034-2	2
18	BOLT, M12X90 8.8 HEX HEAD ZINC	F81004-2	2
19	V-BELT, HA-560 (STOMIL-SANOK)	088562	

## SECTION 8 UP/DOWN SYSTEM

### 8.1 Up/Down Drive Assembly

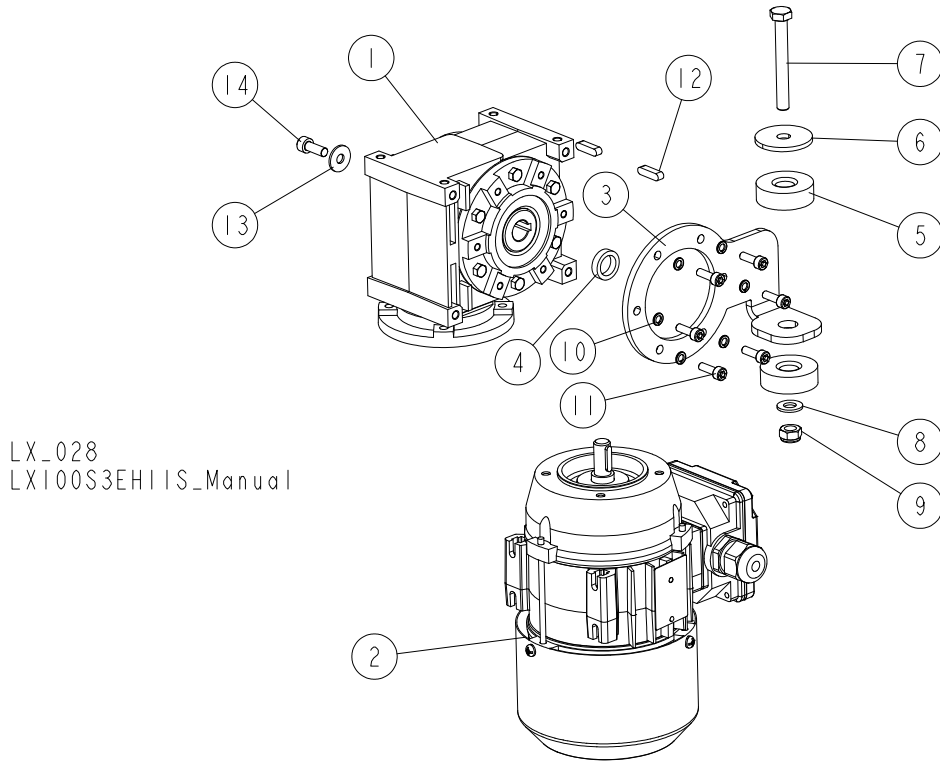

REF.	DESCRIPTION (◆ indicates parts available in assemblies only)	PART #	QTY
	<b>DRIVE ASSEMBLY, AC UP/DOWN</b>	<b>517395</b>	
	<b>MOTOREDUCER, MRA-03/16 [0.25-2800/90/11-B] KM2/W/V6</b>	<b>517394</b>	<b>1</b>
1	GEAR-BOX, MRA-03/16/90/11/KM2/W/V6	517393	1
2	MOTOR, 63B14 (0.25-2800-90/11)	517104	1
3	ARM, TORQUE	517390-1	1
4	BUSHING, 14/20-5	513160	1
5	WASHER, RUBBER	090443	2
6	WASHER, 5X9X38	513086	1
7	BOLT, M8X65 8.8 HEX HEAD FULL THREAD ZINC	F81002-9	1
8	WASHER, 8.4 FLAT ZINC	F81054-1	1
9	NUT, M8 8 HEX NYLON ZINC LOCK	F81032-2	1
10	WASHER, 5.1 SPLIT LOCK ZINC	F81052-2	6
11	SCREW, M5X16-8.8 HEX SOCKET HEAD CAP ZINC	F81000-25	6
12	KEY, A5X5X20 PARALLEL	513320	2
13	WASHER, 6.5 SPECIAL FLAT ZINC	F81053-11	1
14	SCREW, M6X16 8.8 HEX SOCKET HEAD CAP ZINC	F81001-21	1

## 8.2 Blade Height Scale Assembly

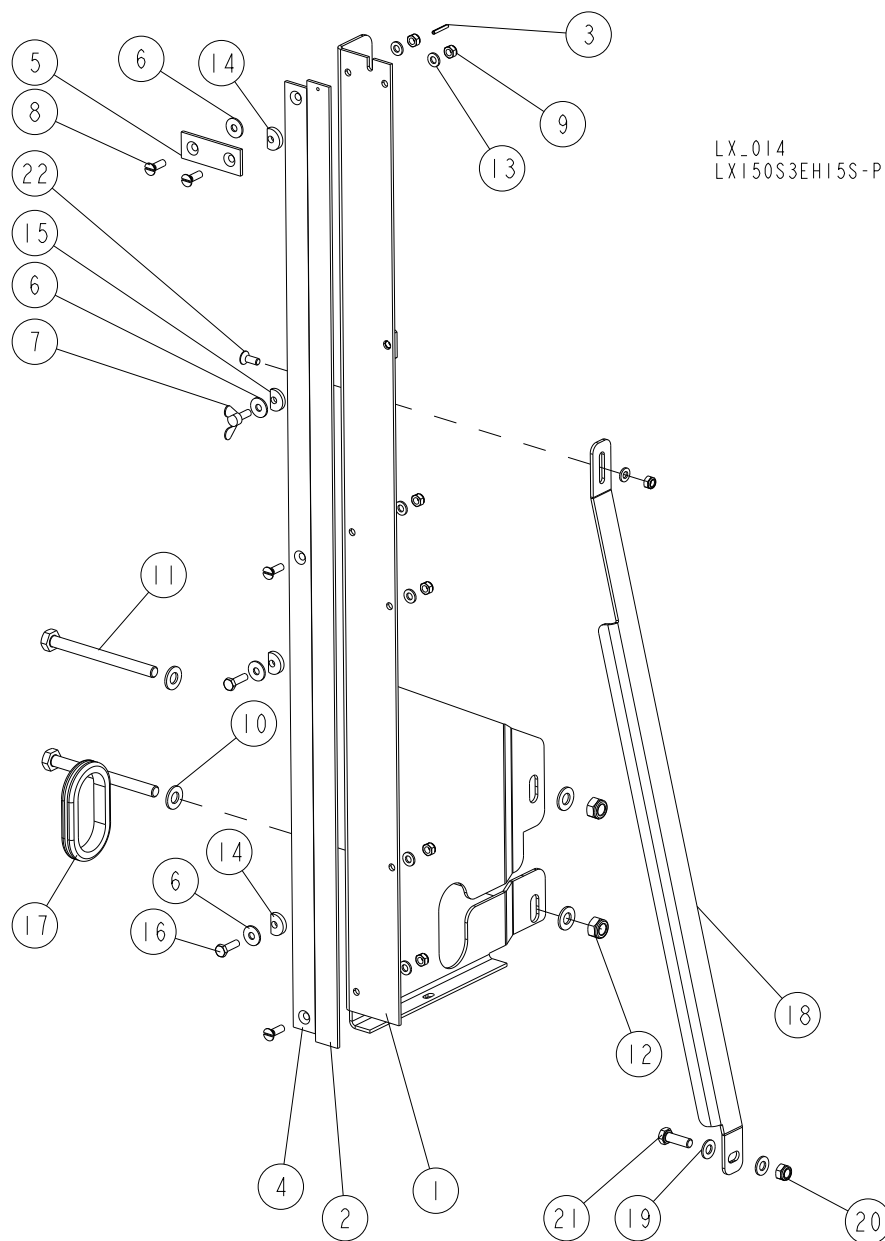

LX\_014  
LXI50S3EHI5S-P\_Manual

REF.	DESCRIPTION (◆ indicates parts available in assemblies only)	PART #	QTY
	<b>BLADE HEIGHT SCALE - COMPLETE (METRIC)</b>	<b>517400</b>	<b>1</b>
1	BRACKET WELDMENT, BLADE HEIGHT SCALE	517401-1	1
2	BAR, INCH SCALE	093133	1
3	PIN, 3X20 GEOMET ROLL	F81044-5	1
4	BAR, SCALE	092750	1
5	BAR, SCALE CLAMPING	093134	1
6	WASHER, 6.5 SPECIAL FLAT ZINC	F81053-11	4
7	SCREW, M6X16 DIN-316/BN-276 ZINC-PL. WING	F81001-16	1
8	SCREW, M6X20-5.8-B SLOTTED COUNTERSUNK HEAD ZINC	F81001-31	4
9	NUT, M6-8-B HEX NYLON ZINC LOCK	F81031-2	7
10	WASHER, 10.5 FLAT ZINC	F81055-1	4



REF.	DESCRIPTION (◆ indicates parts available in assemblies only)	PART #	QTY	
11	BOLT, M10X115-8.8 HEX HEAD	F81003-19	2	
12	NUT, M10-8-B HEX NYLON ZINC LOCK	F81033-1	2	
13	WASHER, 6.4 FLAT ZINC	F81053-1	7	
14	WASHER, 6.2X20X4.5 SPECIAL	503098	3	
15	WASHER, 6.2X20X3.5 SPECIAL	503096	1	
16	BOLT, M6X20 8.8 HEX HEAD FULL THREAD ZINC	F81001-2	2	
17	GROMMET, RUBBER	087065	1	
18	BRACKET, BLADE HEIGHT SCALE SUPPORT	517403-1	1	
19	WASHER, 8.4 FLAT ZINC	F81054-1	2	
20	NUT, M8 8 HEX NYLON ZINC LOCK	F81032-2	1	
21	BOLT, M8X25-8.8-B HEX HEAD FULL THREAD ZINC	F81002-5	1	
22	SCREW, M6X16-10.9 DIN7991 FLAT SOCKET HEAD CAP ZINC	F81001-55	1	

### 8.3 Up/Down Sprockets

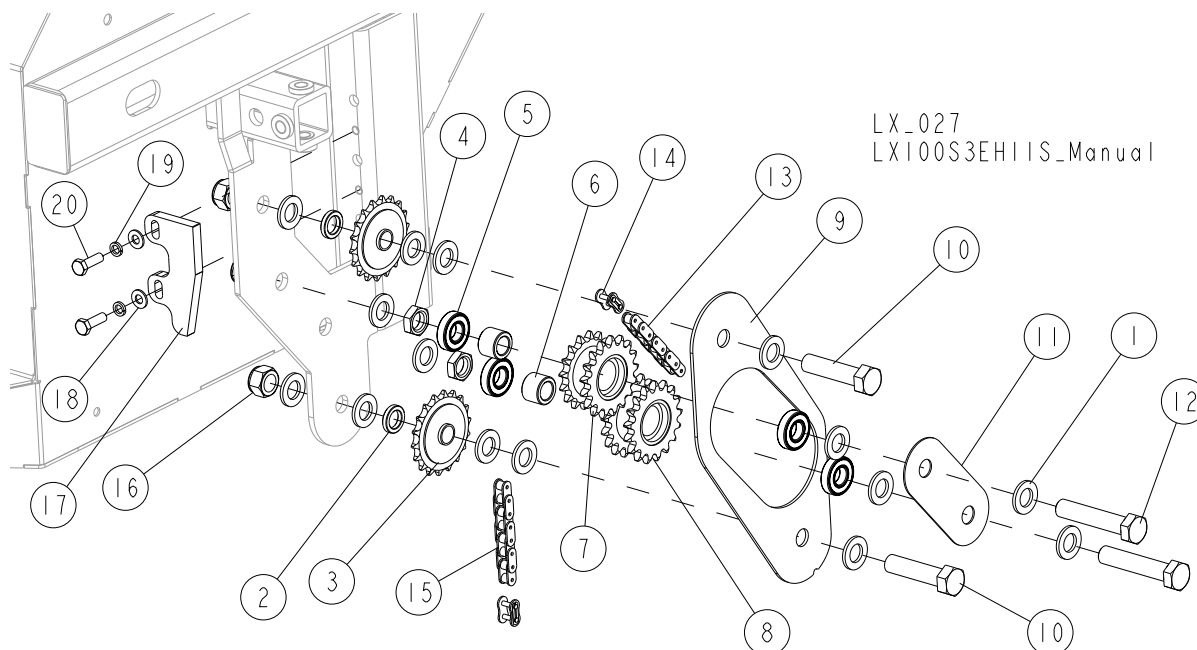

REF.	DESCRIPTION (◆ indicates parts available in assemblies only)	PART #	QTY
1	WASHER, 17 SPLIT LOCK ZINC	F81058-1	18
2	BUSHING	095937-1	2
3	SPROCKET, #40 IDLER 17T 5/8 ID	P04333	2
4	NUT, M16 THIN ZINC	F81036-4	2
5	BEARING, R10-2NSL	P04156	4
6	BUSHING	095938-1	2
7	SPROCKET WELDMENT, 16/17 DUAL	086813-1	1
8	SPROCKET WELDMENT, 17/17 DUAL	086812-1	1
9	GUARD, UP/DOWN CHAIN INTERNAL	014907-1	1
10	BOLT, M16X65 8.8 HEX HEAD FULL THREAD ZINC	F81006-1	2
11	PLATE, UP/DOWN CHAIN GUARD	087104-1	1
12	BOLT, M16X80-8.8 HEX HEAD FULL THREAD ZINC	F81006-11	2
13	CHAIN, #40X15 1/2	P12496	1
14	LINK, #40 MASTER	P04200	2
15	CHAIN, #40X112 1/2"	014831	1
16	NUT, M16-8 HEX NYLON ZINC LOCK	F81036-2	4
	<b>PLATE, LIMIT SWITCH ACTIVATOR - COMPLETE</b>	<b>516510</b>	<b>1</b>
17	PLATE, LIMIT SWITCH ACTIVATOR	516509-1	1
18	WASHER, 8.4 FLAT ZINC	F81054-1	2
19	WASHER, 8.2 SPLIT LOCK ZINC	F81054-4	2
20	BOLT, M8x25-8.8-B HEX HEAD FULL THREAD ZINC	F81002-5	2

## SECTION 9 MOTOR ASSEMBLY

### 9.1 E10/E15 Motor Kit

516793-3\_001  
516793-3\_MANUAL

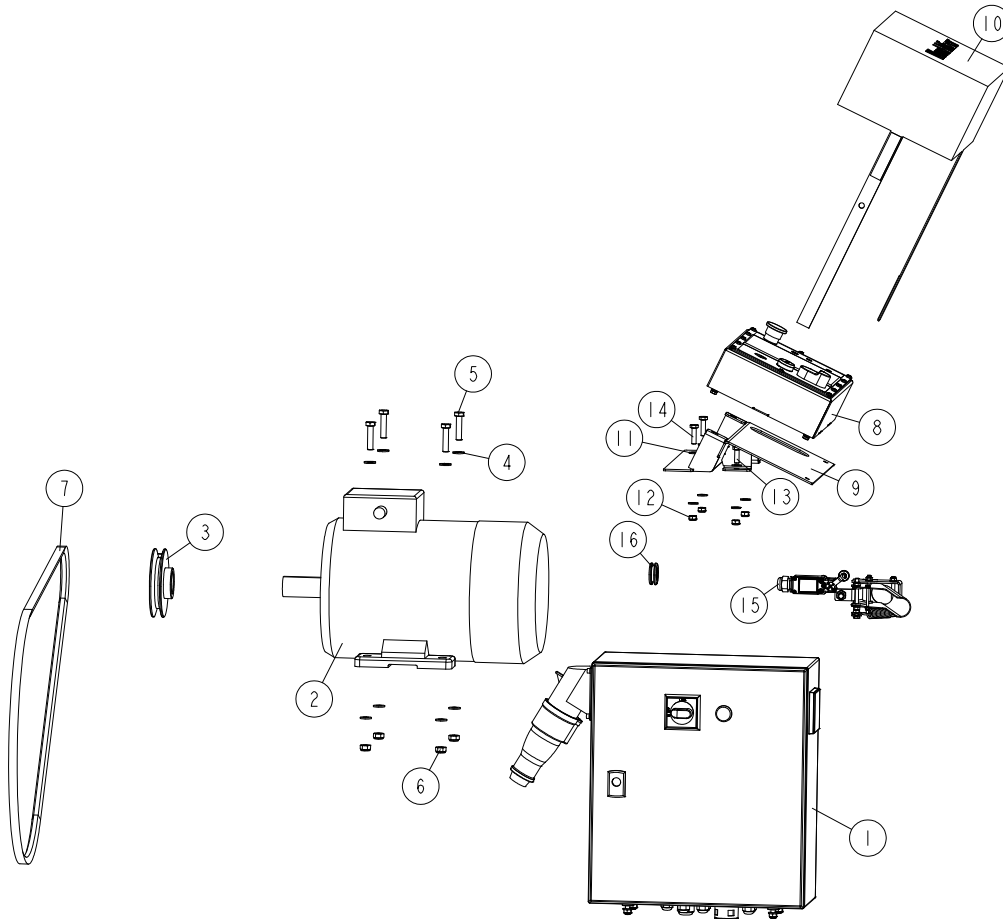

REF.	DESCRIPTION (◆ indicates parts available in assemblies only)	PART #	QTY
	<b>MOTOR KIT, E10 400V</b>	<b>516793-3</b>	<b>1/0</b>
	<b>MOTOR KIT, E15 400V</b>	<b>516789-3</b>	<b>0/1</b>
1	BOX ASSEMBLY, E10 CE ELECTRICAL <a href="#">See Section 9.3</a>	516794	1/0
	BOX ASSEMBLY, E15 CE ELECTRICAL <a href="#">See Section 9.3</a>	516790	0/1
2	MOTOR, 7.5kW 3-PHASE 380V (TAMEL)	085482	1/0
	MOTOR, 11kW 1LE1002-1CA63-4AA4-Z	P85186	0/1
3	PULLEY, E10 MOTOR	086807-1	1/0
	PULLEY, E15 MOTOR 2-GROOVE	091560	0/1
4	WASHER, 10.5 ZINC FLAT	F81055-1	8
5	BOLT, M10X45 HEX HEAD FULL THREAD ZINC	F81003-3	4
6	NUT, M10-8-B HEX NYLON ZINC LOCK	F81033-1	4
7	V-BELT, BX81	014819	1/0
	DRIVE BELT, 2BX81	014819-2	0/1
-	LX100 CONTROL BOX (WITH BRACKET AND COVER)	555400-3	1
8	CONTROL BOX, LX100 AC - COMPLETE <a href="#">See Section 9.5</a>	569501-3	1

# 9 MOTOR ASSEMBLY

## E10/E15 Motor Kit

REF.	DESCRIPTION (◆ indicates parts available in assemblies only)	PART #	QTY	
9	BRACKET, CONTROL BOX MOUNT	555395-1	1	
10	COVER, CONTROL BOX	550414	1	
11	WASHER, 8.4 FLAT ZINC	F81054-1	8	
12	NUT, M8-8-B HEX NYLON ZINC LOCK	F81032-2	4	
13	BOLT, M8X25-8.8-B HEX HEAD FULL THREAD ZINC	F81002-5	2	
14	BOLT, M8X30 8.8 HEX HEAD FULL THREAD ZINC	F81002-7	2	
15	LIMIT SWITCH ASSEMBLY <a href="#">See Section 9.7</a>	555480	1	
16	GROMMET, 22MM RUBBER	087400	1	

## 9.2 E10S/E15S Motor Kit

516793\_001  
516793\_MANUAL

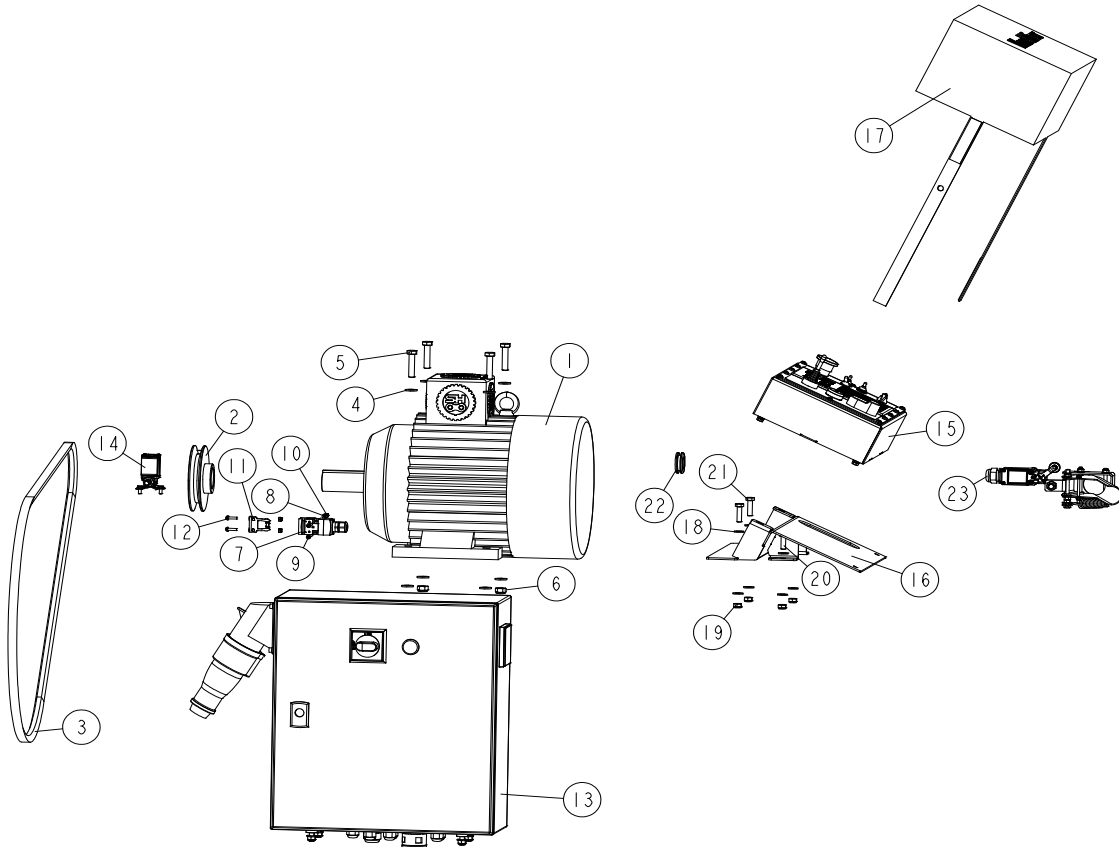

REF.	DESCRIPTION (◆ indicates parts available in assemblies only)	PART #	QTY
-	<b>MOTOR KIT, E10 400V CE</b>	<b>516793</b>	<b>1/0</b>
	<b>MOTOR KIT, E15 400V CE</b>	<b>516789</b>	<b>0/1</b>
1	MOTOR, SG132S-2B-HM 380V	090993	1/0
	MOTOR, 11kW PSg132 S2 - HM	089049	0/1
2	PULLEY, E10 MOTOR	086807-1	1/0
	PULLEY, E15 MOTOR 2-GROOVE	091560	0/1
3	V-BELT, BX81	014819	1/0
	V-BELT, 2BX81	014819-2	0/1
4	WASHER, 10.5 ZINC FLAT	F81055-1	8
5	BOLT, M10X45 HEX HEAD FULL THREAD ZINC	F81003-3	4
6	NUT, M10-8-B HEX NYLON ZINC LOCK	F81033-1	4
7	SWITCH, AZ17-11ZRK SAFETY	094232	1
8	WASHER, 4.3 FLAT ZINC	F81051-2	2
9	SCREW, M4X35 8.8 HEX SOCKET HEAD CAP ZINC	F81011-34	2
10	NUT, M4-B HEX NYLON ZINC LOCK	F81029-1	4
11	KEY, AZ17/170-B5	094422	1
12	SCREW, M4X16 5.8-B CROSS RECESSED PAN HEAD ZINC	F81011-42	2
13	BOX, E10 CE ELECTRICAL <a href="#">See Section 9.3</a>	516794	1

REF.	DESCRIPTION (◆ indicates parts available in assemblies only)	PART #	QTY	
	BOX, E15 CE ELECTRICAL <a href="#">See Section 9.3</a>	516790	1	
14	LUBE KIT, LX100 AC BLADE <a href="#">See Section 9.6</a>	518651	1	
-	LX100 CONTROL BOX ASSEMBLY (WITH BRACKET AND COVER)	555400	1	
15	CONTROL BOX, LX100 AC - COMPLETE <a href="#">See Section 9.4</a>	569501	1	
16	BRACKET, CONTROL BOX MOUNT	555395-1	1	
17	COVER, CONTROL BOX	550414	1	
18	WASHER, 8.4 FLAT ZINC	F81054-1	8	
19	NUT, M8-8-B HEX NYLON ZINC LOCK	F81032-2	4	
20	BOLT, M8X25-8.8-B HEX HEAD FULL THREAD ZINC	F81002-5	2	
21	BOLT, M8X30 8.8 HEX HEAD FULL THREAD ZINC	F81002-7	2	
22	GROMMET, 22MM RUBBER	087400	1	
23	LIMIT SWITCH ASSEMBLY <a href="#">See Section 9.7</a>	555480	1	

**9.3 Electrical Box**

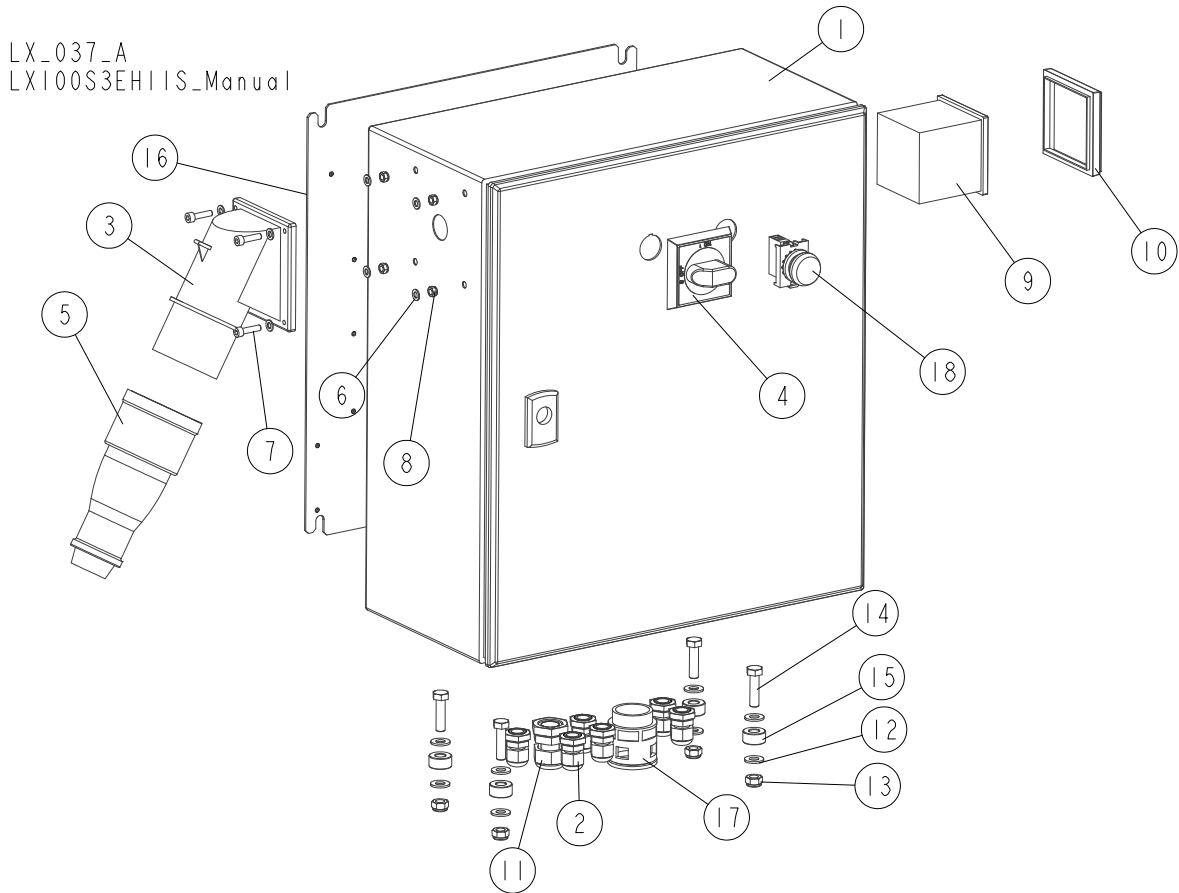

REF.	DESCRIPTION (◆ Indicates Parts Available in Assemblies Only)	PART #	QTY
	<b>BOX ASSEMBLY, E10 CE ELECTRICAL</b>	<b>516794</b>	<b>1</b>
	<b>BOX ASSEMBLY, E15 CE ELECTRICAL</b>	<b>516790</b>	<b>1</b>
1	BOX, CE ELECTRICAL	517879	1
2	GLAND, DP9/H	F81096-2	6
3	PLUG, MAIN W/SWITCH-ADJUSTABLE PHASE GT	E85235	1
4	HANDLE, OHB S2A1 ABB SWITCH	502312-1	1
5	PLUG-IN-SOCKET, PLASTIC SEALED GT	E85236	1
6	WASHER, 5.3 FLAT ZINC	F81052-1	8
7	SCREW, M5X20 8.8 HEX SOCKET HEAD CAP ZINC	F81000-72	4
8	NUT, M5-8-FE/ZN5 DIN985 ZINC-PLATED	F81030-2	4
9	AMMETER, EQB72 25/50A FOR E15 ELECTRIC MOTOR	505371	1
10	COVER, IP65 METER EQ72	505389	1
11	GLAND, DP16/H CABLE	F81096-7	1
12	WASHER, 8.4 FLAT ZINC	F81054-1	8
13	NUT, M8-8-B HEX NYLON ZINC LOCK	F81032-2	4
14	BOLT, M8X30-5.8 HEX HEAD FULL THREAD ZINC	F81002-2	4
15	BUSHING, 9/20-10 ZINC-PLATED	510668-1	4
16	PLATE, ELECTRICAL BOX MOUNT	518178-1	1
17	CONNECTOR, MAXI-FLEX GP29	086576	1
18	LIGHT, M22 LED 24V WHITE CONTROL	090448	1





REF.	DESCRIPTION (◆ Indicates Parts Available In Assemblies Only)	PART #	QTY
5	WASHER, Z 6.1 SPLIT LOCK	F81053-3	4
6	BOLT, M6X16-8.8 HEX HEAD FULL THREAD ZINC	F81001-15	4
-	PANEL, FRONT - COMPLETE	555405	1
7	PANEL, LX100 CONTROL BOX FRONT	555404-1	1
8	DECAL, LX100 AC CONTROL BOX - LEFT	569503	1
9	DECAL, LX100 AC CONTROL BOX - RIGHT	569502	1
10	CONTROLLER, SW-10	500628	1
11	FRAME, SW-08 CONTROLLER REAR	100909	1
12	GASKET, LT15 CONTROL BOX	538732	1
13	POTENTIOMETER, 5K 53C35K	504389	1
14	KNOB, SPEED CONTROL	P06257	1
15	BUTTON, LPCB6644 EMERGENCY STOP	535445-K	1
16	CONTACT, 1NCLPXC01	535440	1
17	BUTTON, LPCBL7191	536908	1
18	ADAPTER, LPXAU120 MOUNTING	535438	3
19	DIAPHRAGM, M22-T-DD MOELLER	090462	1
20	CONTACT, 1NOLPXC10	535439	4
21	BUTTON, LPCBL1163	536921	1
22	JOYSTICK, BLM 2T J200	536914	1
23	SWITCH, TOGGLE	P03027	1
24	WASHER, 1/2X3/4X1/16 NYLON	P05251-1	3
25	SWITCH, TOGGLE 21A DPDT REV MOM SPADE	024200	2
26	BOOT, TOGGLE SWITCH	P02575	3
27	BOLT, #10-24X1/2 PH	F05015-17	12

**9.5 Control Box, LX100 AC (version without CE marking)**

569501-3\_001  
569501-3\_MANUAL

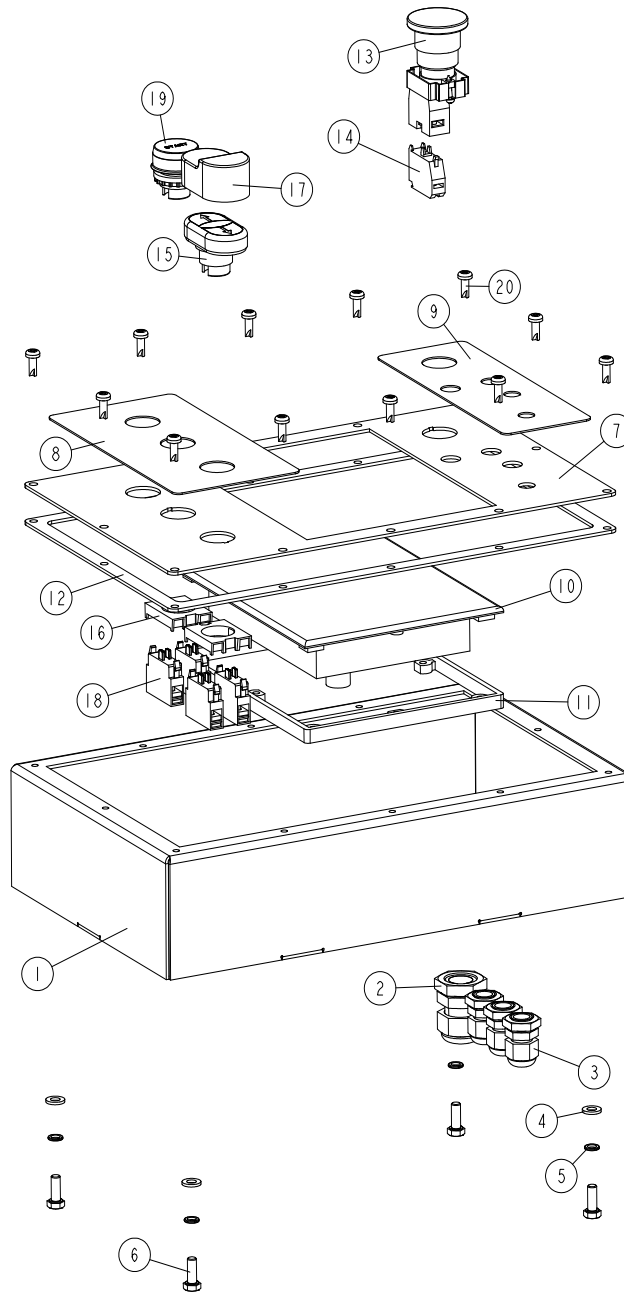

REF.	DESCRIPTION (◆ indicates parts available in assemblies only)	PART #	QTY
-	<b>CONTROL BOX, LX100 AC - COMPLETE</b>	569501-3	1
1	BOX WELDMENT, CONTROL	555401-1	1
2	GLAND, DP16/H CABLE	F81096-7	1
3	GLAND, DP9/H CABLE	F81096-2	3
4	WASHER, 6.4 FLAT ZINC	F81053-1	4
5	WASHER, Z 6.1 SPLIT LOCK ZINC	F81053-3	4
6	BOLT, M6X16-8.8 HEX HEAD FULL THREAD ZIN	F81001-15	4

REF.	DESCRIPTION (◆ indicates parts available in assemblies only)	PART #	QTY	
-	PANEL, FRONT - COMPLETE	555405-3	1	
7	PANEL, LX100 CONTROL BOX FRONT	555404-1	1	
8	DECAL, LX100 AC CONTROL BOX - LEFT	569503	1	
9	DECAL, LX100 AC CONTROL BOX - RIGHT	569502	1	
10	CAP, TVS CONTROL BOX	504378	1	
11	FRAME, SW08 SETWORKS REAR	100909	1	
12	GASKET, LT15 CONTROL BOX	538732	1	
13	BUTTON, LPCB6644 EMERGENCY STOP	535445-K	1	
14	CONTACT, 1NCLPXC01	535440	1	
15	SWITCH, LPCBL7191	536908	1	
16	ADAPTER, LPXAU120 MOUNTING	535438	2	
17	DIAPHRAGM, M22-T-DD	090462	1	
18	CONTACT, 1NOLPXC10	535439	4	
19	BUTTON, LPCBL1163	536921	1	
20	BOLT, #10-24X1/2 PH PAN HEAD TYPE 23	F05015-17	12	

## 9.6 Blade Lube Kit

LX\_044  
LX100S3EHIIS\_Manual

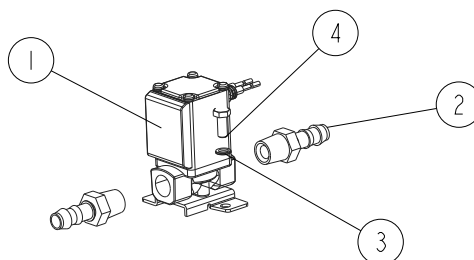

REF.	DESCRIPTION (◆ Indicates Parts Available in Assemblies Only)	PART #	QTY
	<b>LUBE KIT, LX100 AC BLADE</b>	<b>518651</b>	<b>1</b>
1	VALVE, VX212FZ1UAXB SOLENOID	514046	1
2	FITTING, 3/8BARB 1/4NPT MALE NYLON	P04682	2
3	WASHER, 5.1 SPLIT LOCK ZINC	F81052-2	2
4	BOLT, M5 X 12-5.8 HEX HEAD FULL THREAD ZINC	F81000-5	2

## 9.7 Limit Switch Assembly

555480\_001  
555480\_MANUAL

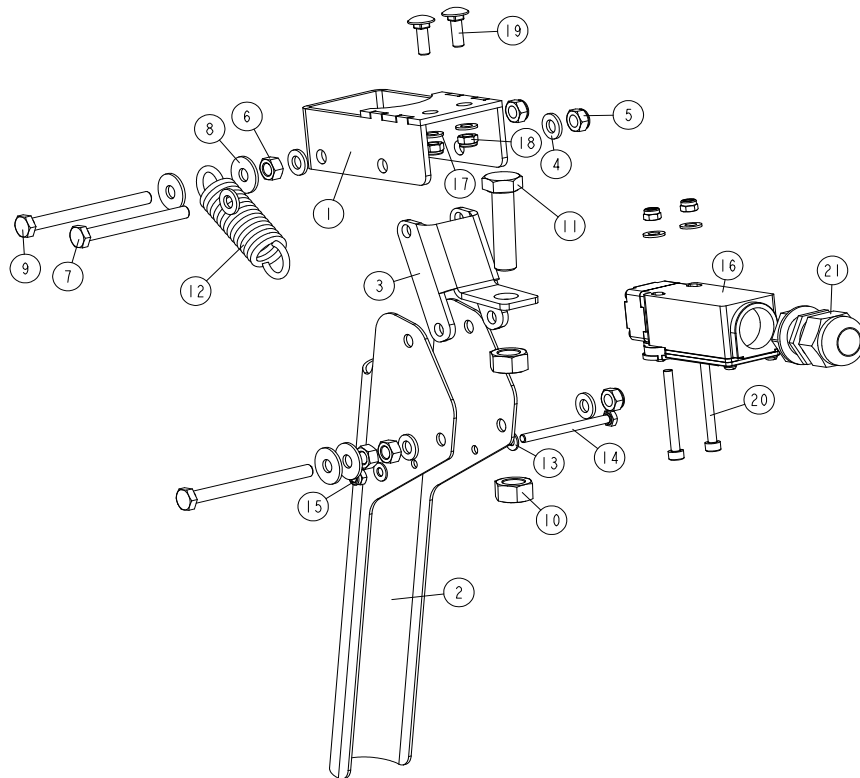

REF.	DESCRIPTION (◆ indicates parts available in assemblies only)	PART #	QTY
-	<b>LIMIT SWITCH ASSEMBLY</b>	555480	1
1	BRACKET WELDMENT	532316-1	1
2	HANDLE, SAFETY	532336-1	1
3	BRACKET	532324-1	1
4	WASHER, 6.4 FLAT ZINC	F81053-1	6
5	NUT, M6-8-B HEX NYLON ZINC LOCK	F81031-2	3
6	NUT, M6-8 HEX ZINC	F81031-1	3
7	BOLT, M6X60-8.8 HEX HEAD FULL THREAD ZIN	F81001-9	1
8	WASHER, 6.5 SPECIAL FLAT ZINC	F81053-11	4
9	BOLT, M6X70 8.8 HEX HEAD FULL THREAD ZIN	F81001-63	2
10	NUT, M10 8 HEX ZINC	F81033-3	2
11	BOLT, M10X40-8.8 HEX HEAD FULL THREAD ZI	F81003-16	1
12	SPRING, 3/4" X 2 7/8" X 12 GAUGE	015479	1
13	WASHER, 4.3 FLAT ZINC	F81051-2	2
14	BOLT, M4X50-8.8 DIN933 HEX HEAD ZINC	F81011-48	1
15	NUT, M4-B HEX NYLON ZINC LOCK	F81029-1	3
16	SWITCH, FA138 Z11LIMIT	100931	1
17	WASHER, 5.3 FLAT ZINC	F81052-1	4
18	NUT, M5-8 DIN985 HEX NYLON ZINC LOCK	F81030-2	2
19	BOLT, M5X16 DIN 603 CARRIAGE	F81000-75	2
20	SCREW, M4X40-8.8 SOCKET HEAD ZINC	F81011-37	2
21	GLAND, DP 20 HML CABLE	F81096-41	1