

Wood-Mizer®

Parts Manual

LT15SA Electric
LT15SA Gasoline

rev.A2.05
rev. A2.07



Safety is our #1 concern! Read and understand all safety information and instructions before operating, setting up or maintaining this machine.

Form #795

Table of Contents

Section-Page

SECTION 1	GENERAL INFORMATION	1-1
1.1	How To Use the Parts List.....	1-1
1.2	Sample Assembly	1-1
SECTION 2	BED FRAME	2-1
2.1	Log Side Support Assembly	2-1
2.2	Bed Section Connecting Hardware	2-2
2.3	Stationary Leg Kit	2-4
2.4	Outrigger Leg Kit	2-5
2.5	Log Clamp Assembly	2-6
2.6	Auxiliary Bed Rail Assembly	2-7
2.7	Manual Toe Board (Optional)	2-8
2.8	Complete Winch	2-10
2.9	”M” Type Bed Frame Section (LT15 Sawmills Only).....	2-12
	2-12
2.10	”S” Type Bed Frame Section, LT15 1950	2-13
2.11	Mast Track Extension	2-14
2.12	Mast Track Extension Tube	2-15
2.13	Additional Bed Frame Sections with Outrigger Legs	2-16
2.14	Log Loading Ramp Assembly 097977	2-17
2.15	Loading Ramp Assembly 097483	2-18
2.16	Ramp Bracket 507518	2-19
SECTION 3	BLADE GUIDE ROLLERS & ARM	3-1
3.1	Blade Guide Assembly, Idle Side.....	3-1
3.2	Blade Guide Assembly, Drive Side.....	3-2
3.3	Blade Guide Roller Guard	3-4
3.4	Blade Guide Arm with Lever (094136).....	3-5
SECTION 4	BLADE WHEELS & TENSIONER	4-1
4.1	Blade Wheel Assembly, Drive Side	4-1
4.2	Wide Blade Wheel Assembly, Drive Side, E15 Motor	4-2
4.3	Blade Wheel Assembly, Idle Side	4-3
4.4	Blade Tensioner Assembly	4-4
4.5	Motor	4-6
4.6	Blade Brake	4-7
4.7	Blade Brake, E15 Motor	4-9

Table of Contents

Section-Page

SECTION 5 SAW HEAD

5-1

5.1	Blade Housing Cover	5-1
5.2	Water Lube Assembly	5-3
5.3	Oil Tank	5-4
5.4	LT10 Saw Head Decals	5-5
5.5	Control Box	5-7
5.6	Guard Assembly 598105	5-9

SECTION 6 FEED SYSTEM

6-1

6.1	Track Rail, Rollers & Travel Pins	6-1
6.2	Track Roller Cover Assembly	6-3
6.3	Track Rollers	6-4
6.4	Lower Sprocket Assembly	6-5
6.5	Track Rail, Rollers & Travel Pins	6-6
6.6	Power Cord Bracket (Part No. 097449)	6-7

SECTION 7 UP/DOWN SYSTEM

7-1

7.1	Up/Down Crank Assembly	7-1
7.2	Operator's Bracket (Option)	7-2
7.3	Up/Down Drive Sprocket Assembly	7-3
7.4	Slide Pads	7-5
7.5	Mast Guide	7-6
7.6	Blade Height Scale Assembly	7-7
7.7	Scale Mount Bracket Assembly	7-9
7.8	LT10 Electric Up/Down System (Option)	7-10
7.9	Electric Up/Down Control Assembly (Option for CE Version)	7-12
7.10	Limit Switch Activator Plate	7-13

SECTION 8 MOTOR KITS

8-1

8.1	Motor Kit, LT15SA EH15	8-1
8.2	Motor Kit, LT15SA EH7S/EH10S	8-2
8.3	EH7/EH10/EH15 Electrical Box	8-4
8.4	Motor Brake Assembly	8-6

SECTION 1 GENERAL INFORMATION

1.1 How To Use the Parts List

- Use the index above to locate the assembly that contains the part you need.
- Go to the appropriate section and locate the part in the illustration.
- Use the number pointing to the part to locate the correct part number and description in the table.
- Parts shown indented under another part are included with that part.
- Parts marked with a diamond (◆) are only available in the assembly listed above the part.

See the sample table below. Sample Part #A01111 includes part F02222-2 and subassembly A03333. Subassembly A03333 includes part S04444-4 and subassembly K05555. The diamond (◆) indicates that S04444-4 is not available except in subassembly A03333. Subassembly K05555 includes parts M06666 and F07777-77. The diamond (◆) indicates M06666 is not available except in subassembly K05555.

1.2 Sample Assembly				
REF.	DESCRIPTION (◆ Indicates Parts Available In Assemblies Only)	PART #	QTY	
	Sample Assembly, Complete (Includes All Indented Parts Below)	A01111	1	
1	Sample Part	F02222-22	1	
	Sample Subassembly (Includes All Indented Parts Below)	A03333	1	
2	Sample Part (◆ Indicates Part Is Only Available With A03333)	S04444-4	1	◆
	Sample Subassembly (Includes All Indented Parts Below)	K05555	1	
3	Sample Part (◆ Indicates Part Is Only Available With K05555)	M06666	2	◆
4	Sample Part	F07777-77	1	

To Order Parts:

- From Europe call our European Headquarters and Manufacturing Facility in Kolo, Poland at **+48-63-2626000**. From the continental U.S., call our toll-free Parts hotline at **1-800-525-8100**. Have your customer number, vehicle identification number, and part numbers ready when you call. From other international locations, contact the Wood-Mizer distributor in your area for parts.

Office Hours:

Country	Monday - Friday	Saturday	Sunday
Poland	7-15	Closed	Closed
US	8 a.m.- 5 p.m.	8 a.m.- 12 p.m.	Closed



CAUTION! It is strongly recommended that only original spare parts be used.

SECTION 2 BED FRAME

2.1 Log Side Support Assembly

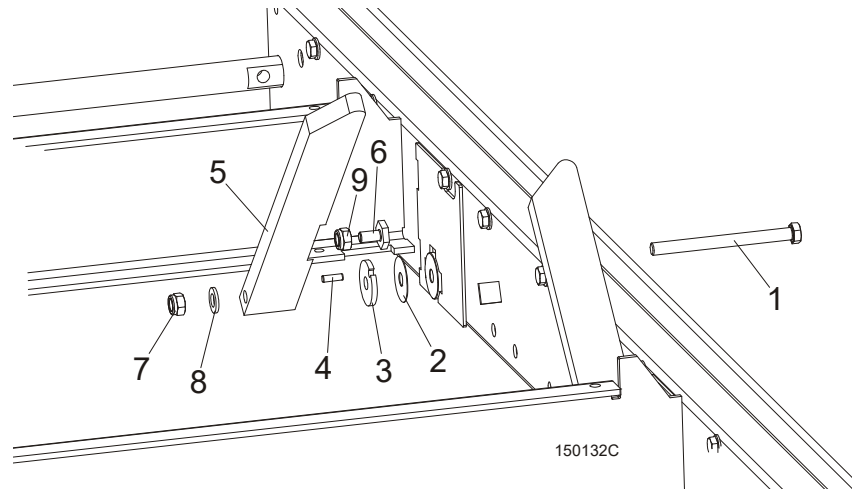

REF.	DESCRIPTION (◆ Indicates Parts Available In Assemblies Only)	PART #	QTY
1	BOLT, M12X140-8.8 HEX HEAD ZINC	F81004-35	1
2	WASHER, 33/64 X 1 3/4 X 1/32" NYLON	014972	1
3	WASHER, LT15 THICK SPACER	085981-1	1
	SUPPORT, LT15 LOG SIDE COMPLETE	085982-1	1
4	PIN, H 6n6x20 60HRC ROLL	100472	1
5	PLATE, LT15 LOG SIDE SUPPORT	085980	1
6	BOLT, M10x20 SPECIAL	100076-1	1
7	NUT, M12-8 HEX NYLON ZINC LOCK	F81034-2	1
8	WASHER, 13 FLAT ZINC	F81056-1	1
9	NUT, M10-8-B HEX ZINC	F81033-3	1

2.2 Bed Section Connecting Hardware

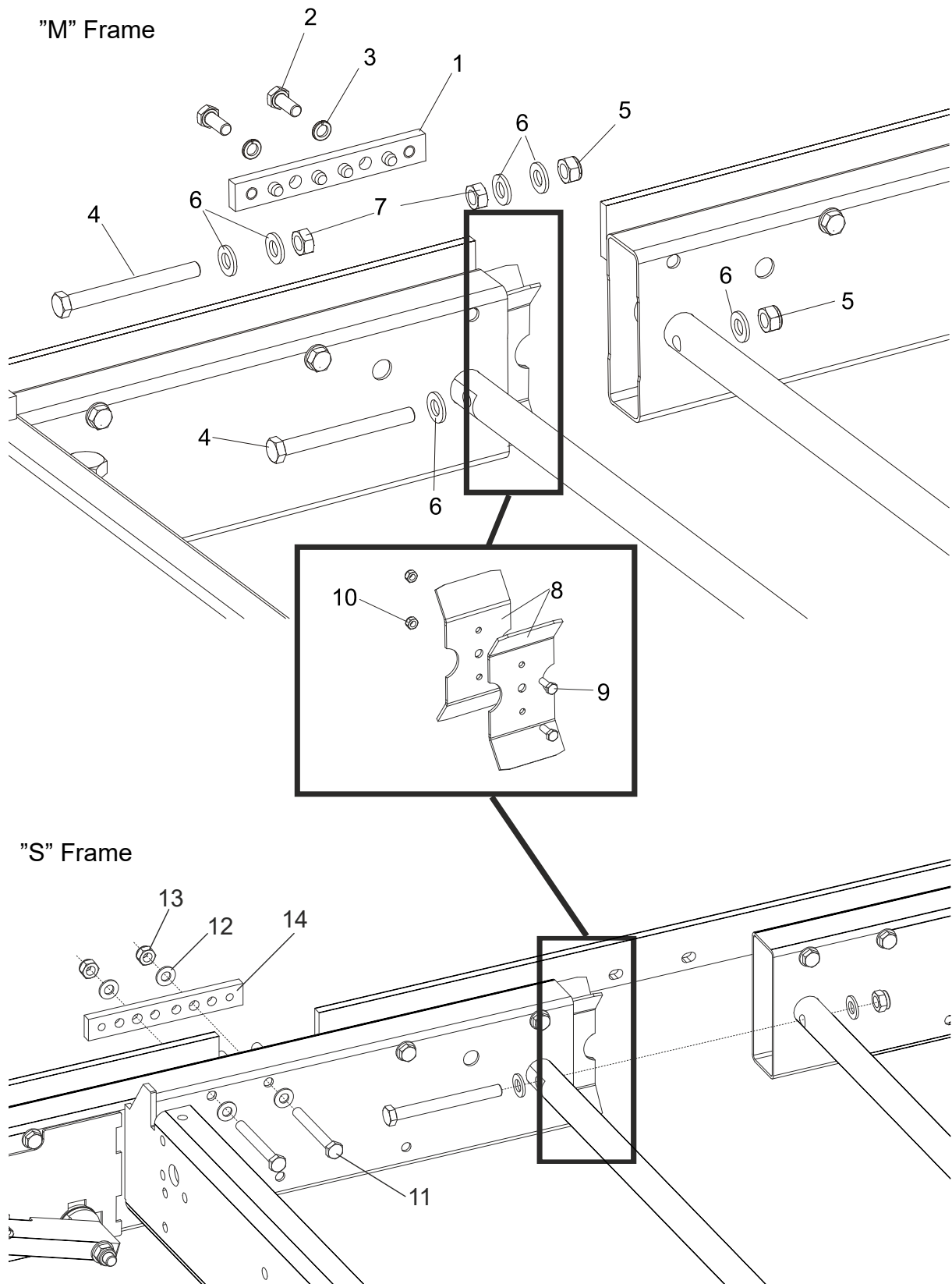

REF.	DESCRIPTION (◆ Indicates Parts Available In Assemblies Only)	PART #	QTY	
1	SPLICE, TRACK BAR PINNED ZINC-PLATED	086659-1	1	
2	BOLT, M10x25-8.8 HEX HEAD FULL THREAD ZINC	F81003-11	2	
3	WASHER, 10.2 SPLIT LOCK ZINC	F81055-2	2	
4	BOLT, M12x120 8.8 HEX HEAD ZINC	F81004-38	2	
5	NUT, M12-8 HEX NYLON ZINC LOCK	F81034-2	2	
6	WASHER, 13 FLAT ZINC	F81056-1	6	
7	NUT, M12-8-B HEX ZINC	F81034-1	2	
	CONNECTOR, LT15 BED FRAME SECTION	506288 ¹	2	
8	PLATE, BED SECTION CONNECTOR	506287-1	1	
9	BOLT, M6x16 8.8 HEX HEAD FULL THREAD ZINC	F81001-15	2	
10	NUT, M6-8-B HEX NYLON ZINC LOCK	F81031-2	2	
11	BOLT, M10X85-8.8 HEX HEAD ZINC	F81003-125	2	
12	WASHER, 10.5 FLAT ZINC	F81055-1	4	
13	NUT, M10-8-B HEX NYLON ZINC LOCK	F81033-1	2	
14	SPLICE, LT15 TRACK BAR PINNED	086660	1	

¹ 2 pieces for each bed section

2 BED FRAME

Stationary Leg Kit

2.3 Stationary Leg Kit

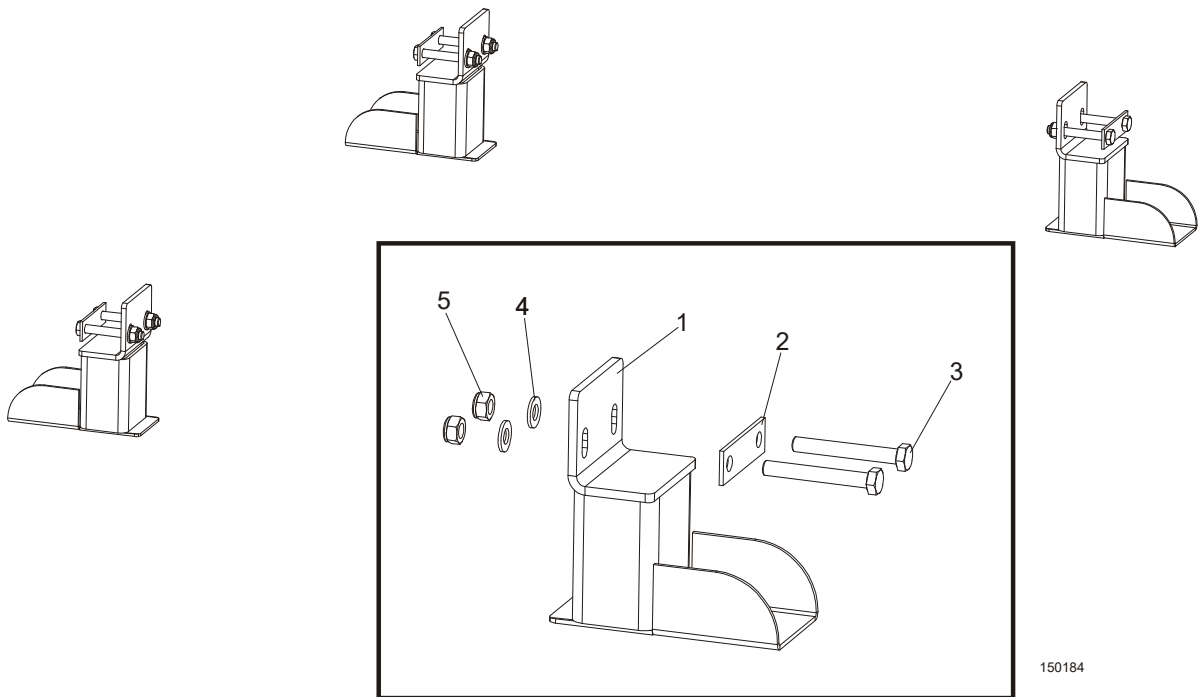

150184

REF.	DESCRIPTION (◆ Indicates Parts Available In Assemblies Only)	PART #	QTY
	STATIONARY LEG KIT FOR 1950 MM BED SECTION	100069	1
1	Leg, LT15 Stationary Bed	100064-1	4
2	Washer, LT15 Bed Leg	085994-1	4
3	Bolt, M10x75-8.8 Hex Head Zinc	F81003-15	8
4	Washer, 10.5 Flat Zinc	F81055-1	8
5	Nut, M10-8-B Hex Nylon Zinc Lock	F81033-1	8
	STATIONARY LEG KIT FOR 2700 MM BED SECTION	100070	1
1	Leg, LT15 Stationary Bed	100064-1	6
2	Washer, LT15 Bed Leg	085994-1	6
3	Bolt, M10x75-8.8 Hex Head Zinc	F81003-15	12
4	Washer, 10.5 Flat Zinc	F81055-1	12
5	Nut, M10-8-B Hex Nylon Zinc Lock	F81033-1	12

2.4 Outrigger Leg Kit

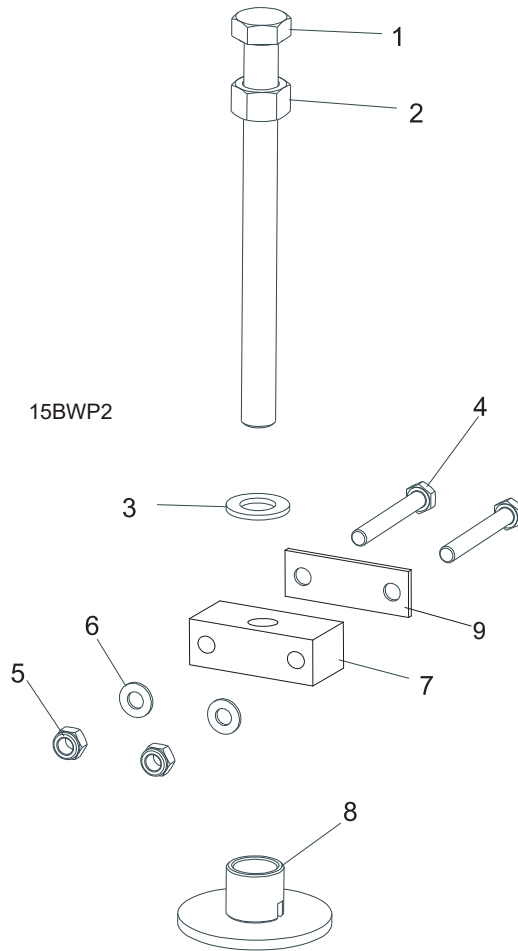

REF.	DESCRIPTION (◆ Indicates Parts Available In Assemblies Only)	PART #	QTY
	OUTRIGGER LEG KIT FOR 1950 MM BED SECTION (LT15S3)	095232 ¹	3
	OUTRIGGER LEG KIT FOR 2700 MM BED SECTION (LT15M2)	095234 ²	2
1	Bolt, M20x240-8.8 Hex Head Full Thread Zinc	F81007-1	1
2	Nut, M20-8 Hex Zinc	F81037-1	1
3	Washer, 21 Flat Zinc	F81059-2	1
4	Bolt, M10x120-8.8 Hex Head Zinc	F81003-58	2
5	Nut, M10-8-B Hex Nylon Zinc Lock	F81033-1	2
6	Washer, 10.5 Flat Zinc	F81055-1	2
7	Block, LT15 Leg Mount	095745-1	1
8	Plate Weldment, LT15 Leg Foot Zinc-Plated	087771-1	1
9	Washer, LT15 Bed	085994-1	1

¹ Four legs are mounted to each 1950-mm long bed section.

² Six legs are mounted to each 2700-mm long bed section.

2.5 Log Clamp Assembly

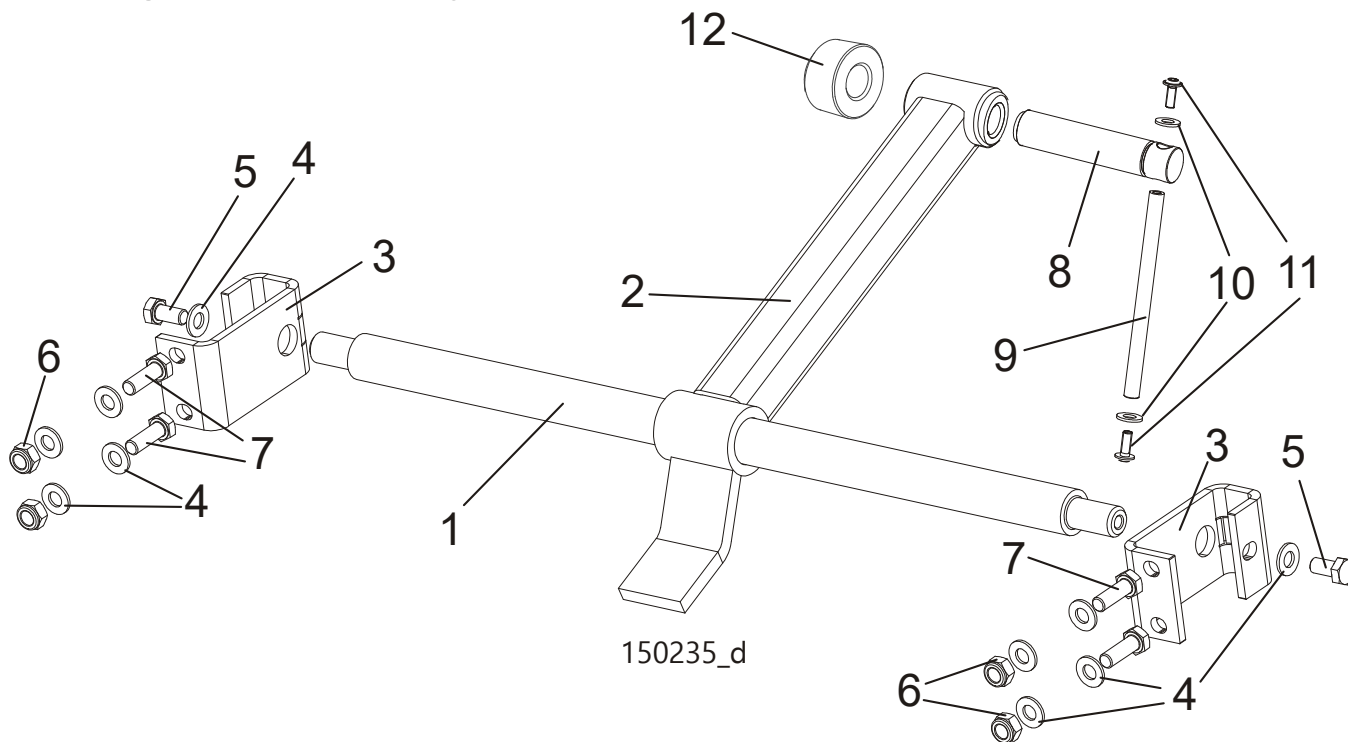

REF.	DESCRIPTION (◆ Indicates Parts Available In Assemblies Only)	PART #	QTY
	LOG CLAMP ASSEMBLY, LT15/15 COMPLETE	507565	2
1	ROD MAIN CLAMP	500343-1	1
2	ARM, CLAMP LX50 ZINC	530701-1	1
3	BRACKET, LOG CLAMP MOUNT ZINC	506535-1	2
4	WASHER, 10.5 FLAT ZINC	F81055-1	10
5	BOLT, M10x20-5.8 HEX HEAD FULL THREAD ZINC	F81003-1	2
6	NUT, M10-8-B NYLON HEX ZINC LOCK	F81033-1	4
7	BOLT, M10X30-5.8 HEX HEAD FULL THREAD	F81003-2	4
	CLAMP BOLT - COMPLETE	507563	1
8	CLAMP BOLT	507463	1
	ROD - COMPLETE	511924	1
9	ROD, ZINC-PLATED	511923-1	1
10	WASHER, 8.4 FLAT ZINC	F81054-1	2
11	BOLT, M6x16 BN 11252 "BOSSARD"	F81001-24	2
12	CAP, MOUNTING	T00414	1

2.6 Auxiliary Bed Rail Assembly

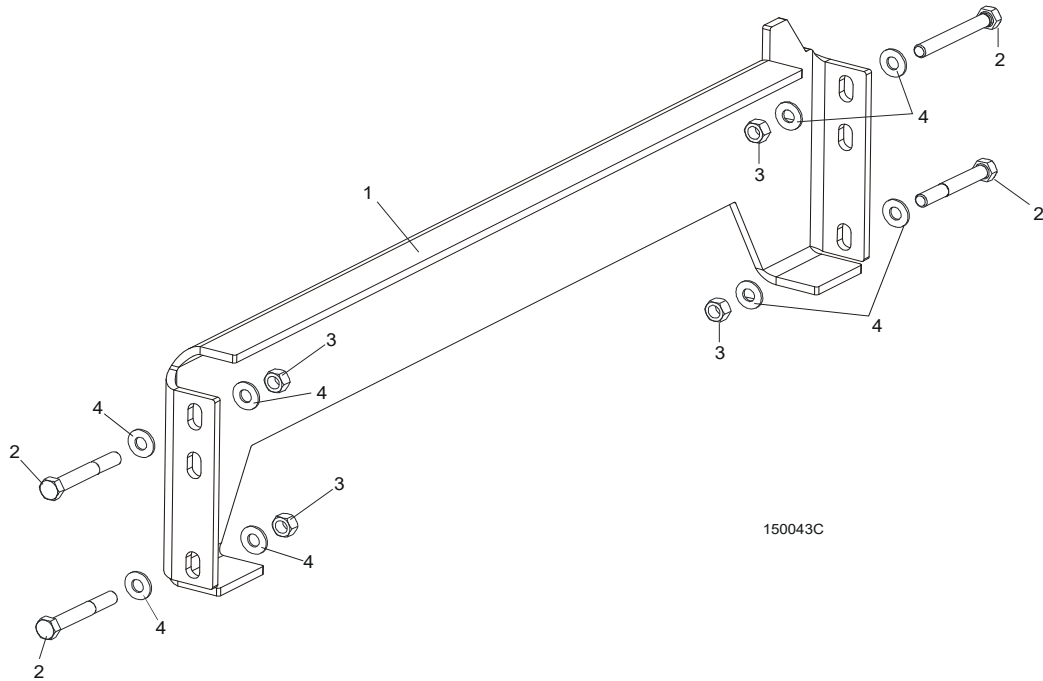

REF.	DESCRIPTION (◆ Indicates Parts Available In Assemblies Only)	PART #	QTY	
1	RAIL WELDMENT, LT15 AUXILIARY BED	095490-1	1	◆
2	BOLT M10X75-8.8 HEX HEAD ZINC	F81003-15	4	
3	NUT, M10-8-B HEX NYLON ZINC LOCK	F81033-1	4	
4	WASHER 10.5 ZINC FLAT	F81055-1	8	

2.7 Manual Toe Board (Optional)

534596_001_A
534596_MANUALS

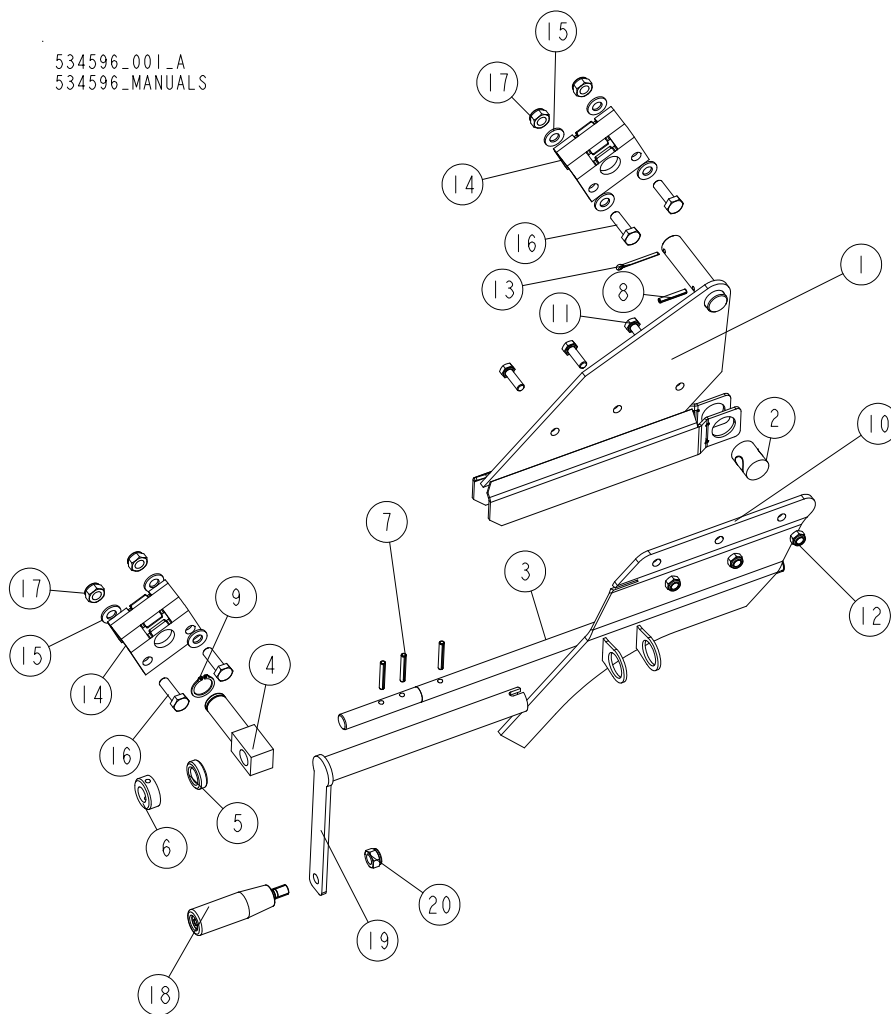

REF.	DESCRIPTION (* indicates parts available in assemblies only)	PART NO.	QTY
-	MANUAL TOE BOARD W/CRANK HANDLE (SINGLE)	534596	1
-	LT15 MANUAL TOE BOARD	534573	1
-	MANUAL TOE BOARD W/CRANK HANDLE (DOUBLE)	534596	1
-	LT15 MANUAL TOE BOARD	534573	2
-	HANDLE, TOE BOARD - COMPLETE	534595	1
1	PLATE WELDMENT, MANUAL TOE BOARD FRONT	094927-1	1
2	PIN, THREADED (MANUAL TOE BOARD)	090017	1
3	SHAFT, MANUAL TOE BOARD	580809-1	1
4	PIVOT, MANUAL TOE BOARD SHAFT ZINC-PLATED (1)	094931-1	1
5	BEARING, 5/8 THRUST	581701	1
6	RING, 16 ADJUSTING	F81039-30	1
7	PIN, 5X35-N-C PN-EN ISO 8752 ROLL	F81044-9	3
8	PIN, 4X30 ROLL ZINC	F81044-7	1
9	RING, Z 22 OUTSIDE RETAINING	F81090-24	1

REF.	DESCRIPTION (* indicates parts available in assemblies only)	PART NO.	QTY	
10	PLATE, MANUAL TOE BOARD COVER - COMPLETE	534593-1	1	
11	BOLT, M8X25-8.8-B HEX HEAD FULL THREAD ZINC	F81002-5	3	
12	NUT, M8-8-B HEX NYLON LOCK ZINC	F81032-2	3	
13	PIN, S-ZN, 4 X 25 COTTER	F81043-2	1	
14	PLATE	534574-1	2	
15	WASHER, 10.5 FLAT ZINC	F81055-1	7	
16	BOLT, DIN 933-M10X30 8.8-A2E	F81003-111	4	
17	NUT, M10-8-B NYLON HEX ZINC LOCK	F81033-1	4	
-	HANDLE, MANUAL TOE BOARD CRANK	500600	1	
18	KNOB, L=85 M10, RO11-M10 PLASTIC CRANK HANDLE	086338	1	
19	MANUAL TOE BOARD KNOB - WELDMENT	500599-1	1	
20	NUT, M10-8-B NYLON HEX ZINC LOCK	F81033-1	1	

2.8 Complete Winch

538991_001
538991_MANUAL

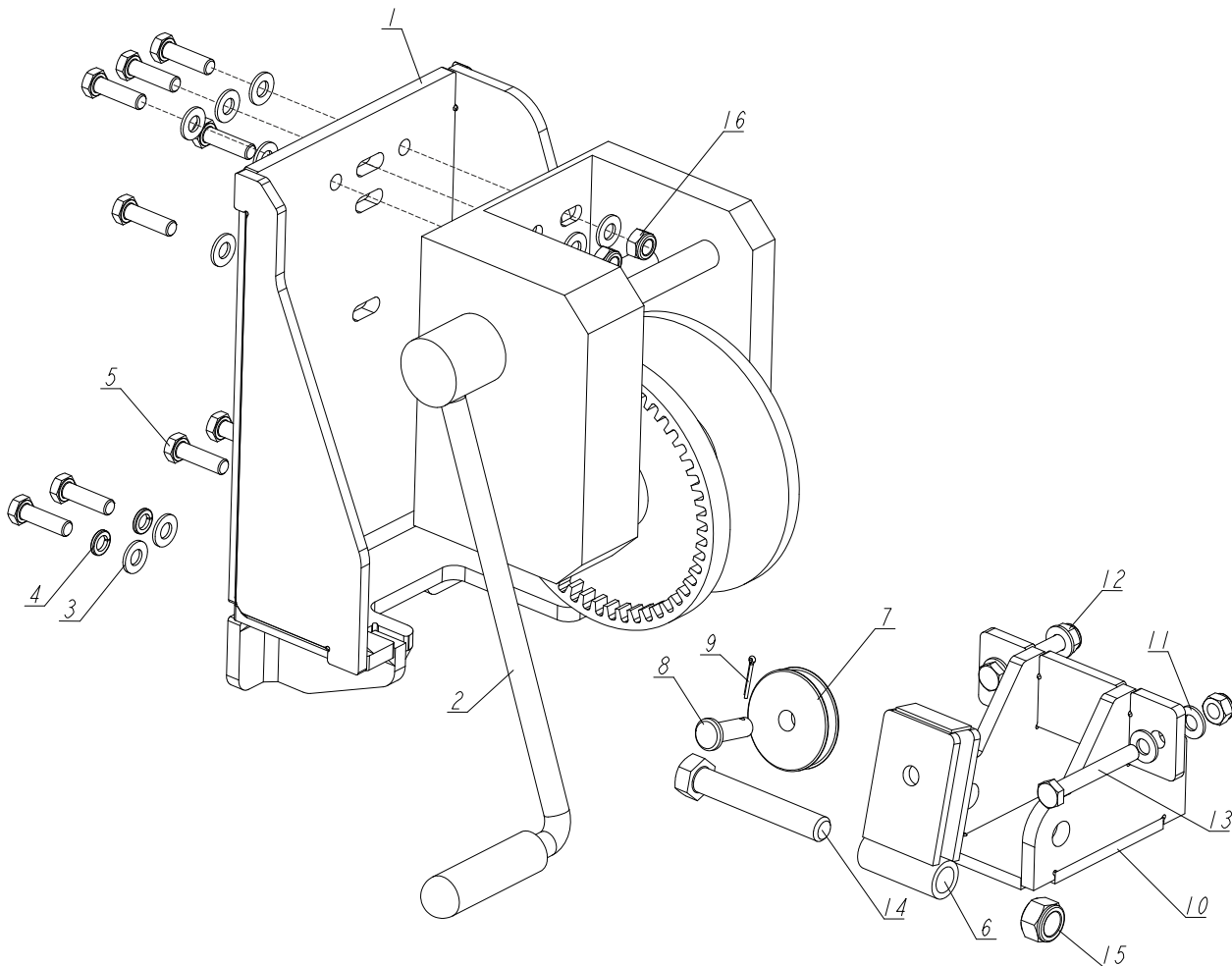

REF.	DESCRIPTION (* indicates parts available in assemblies only)	PART #	QTY
-	COMPLETE WINCH	538991	1
1	MOUNT WELDMENT, WINCH	538983-1	1
2	WINCH, AL-KO TYPE 901	096453	1
3	WASHER, 10.5 FLAT ZINC	F81055-1	12
4	WASHER, Z 10.2 SPLIT LOCK ZINC	F81055-2	4
5	BOLT, M10X35 8.8 HEX HEAD FULL THREAD ZINC	F81003-17	9
-	BRACKET, CABLE GUIDE PULLEY MOUNT - COMPLETE	538993	1
6	BRACKET, CABLE GUIDE PULLEY MOUNT	538990-1	1
7	PULLEY, CABLE GUIDE ZINC-PLATED	091273-1	1
8	PIN, B-12X35-FS/ZN5	F81049-1	1
9	PIN, S-ZN-2.5X20 COTTER	F81043-1	1
10	MOUNT WELDMENT, GUIDE PULLEY BRACKET	538994-1	1
11	WASHER, 10.5 FLAT ZINC	F81055-1	4
12	NUT, M10-8-B HEX NYLON ZINC LOCK	F81033-1	2

REF.	DESCRIPTION (* indicates parts available in assemblies only)	PART #	QTY	
13	BOLT, M10X75-8.8 HEX HEAD ZINC	F81003-15	2	
14	BOLT, M16X100-8.8 HEX HEAD FULL THREAD ZINC	F81006-2	1	
15	NUT, M16-8 HEX NYLON ZINC LOCK	F81036-2	1	
16	NUT, M10-8-B HEX NYLON ZINC LOCK	F81033-1	5	

2

BED FRAME

"M" Type Bed Frame Section (LT15 Sawmills Only)

2.9 "M" Type Bed Frame Section (LT15 Sawmills Only)

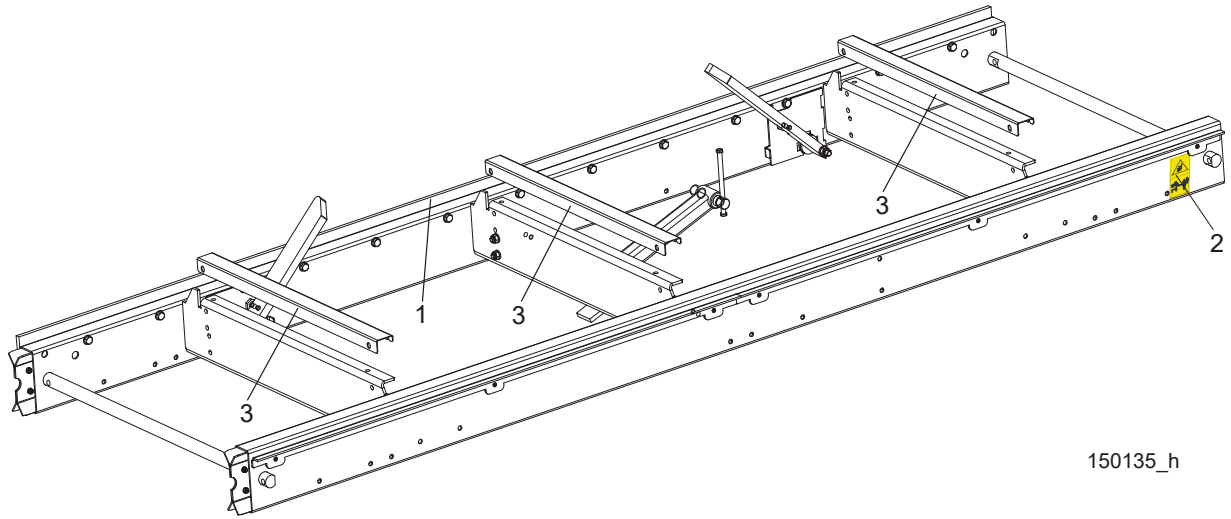

150135_h

REF.	DESCRIPTION (◆ Indicates Parts Available In Assemblies Only)	PART #	QTY
	LT15 BED SECTION ASSEMBLY - LONG	094697	
1	Bar, LT15 2700 Track Zinc-Plated	538935-1	1
2	DECAL, KEEP AWAY DANGER, PICTOGRAM	099221	1
3	COVER, BED RAIL LT15/15	509300 ¹	3

¹ Option

2.10 "S" Type Bed Frame Section, LT15 1950

538800_001
538800_MANUALS

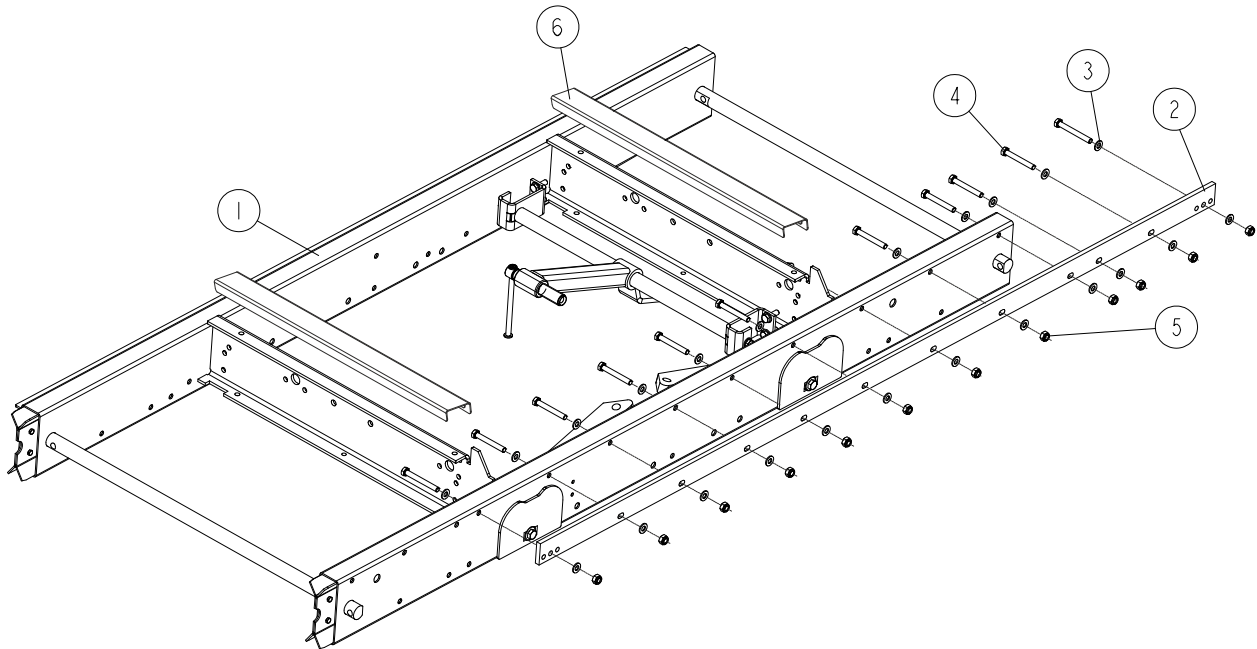

REF.	DESCRIPTION (◆ Indicates Parts Available In Assemblies Only)	PART #	QTY
-	SECTION, LT 15 1950 BED FRAME - COMPLETE	538800	1
1	FRAME WELDMENT, LT15 1950 BED	538801-1	1
2	RAIL, LT15 1950 TRACK	538799-1	1
3	WASHER, 10.5 FLAT ZINC	F81055-1	24
4	BOLT, M10X75-8.8 HEX HEAD ZINC	F81003-15	10
5	NUT, M10-8-B HEX NYLON ZINC LOCK	F81033-1	12
6	COVER, LT15 BED RAIL	509300 ¹	2

¹ Option

2.11 Mast Track Extension

538808_001_A
538808_MANUAL

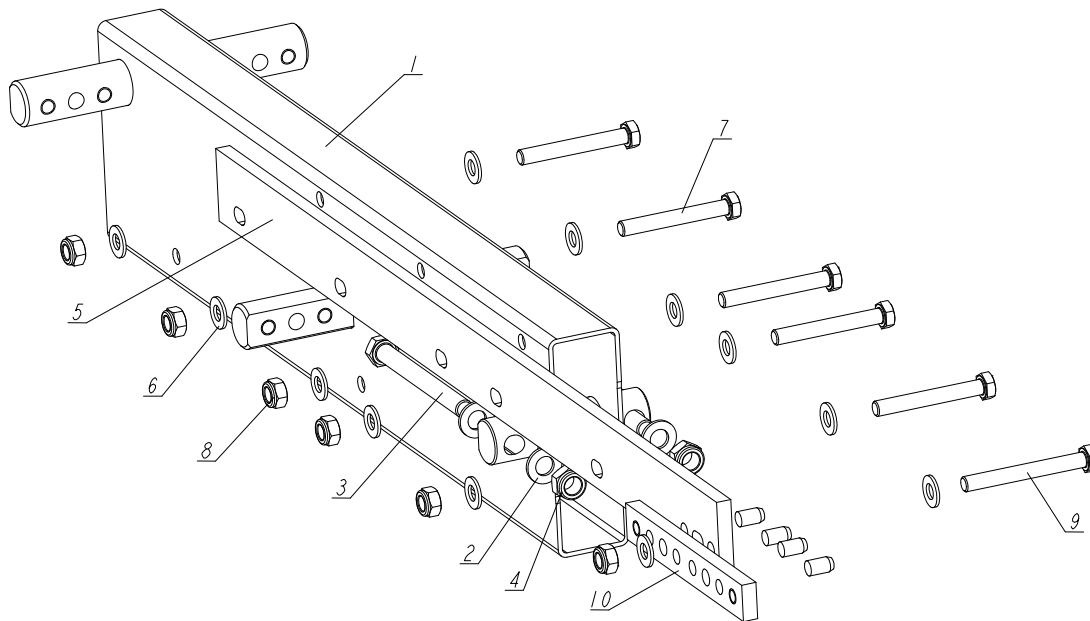

REF	DESCRIPTION (◆ indicates parts available in assemblies only)	PART #	QTY
-	EXTENSION, MAST TRACK REAR - COMPLETE	538808	1
1	TUBE, MAST TRACK EXTENSION	538809-1	1
2	WASHER, 13 FLAT ZINC	F81056-1	4
3	BOLT M12X120 8.8 FE/ZN5	F81004-38	2
4	NUT, M12 8 HEX NYLON ZINC LOCK	F81034-2	2
5	BAR, EXTENSION TRACK ZINC-PLATED	538811-1	1
6	WASHER, 10.5 FLAT ZINC	F81055-1	12
7	BOLT, M10X75-8.8 HEX HEAD ZINC	F81003-15	5
8	NUT, M10-8-B HEX NYLON ZINC LOCK	F81033-1	6
9	BOLT, M10X85-8.8 HEX HEAD ZINC	F81003-125	1
10	BED SECTION CONNECTOR, LT15	086659-1	1

2.12 Mast Track Extension Tube

538807_001_A
 538807_MANUALS

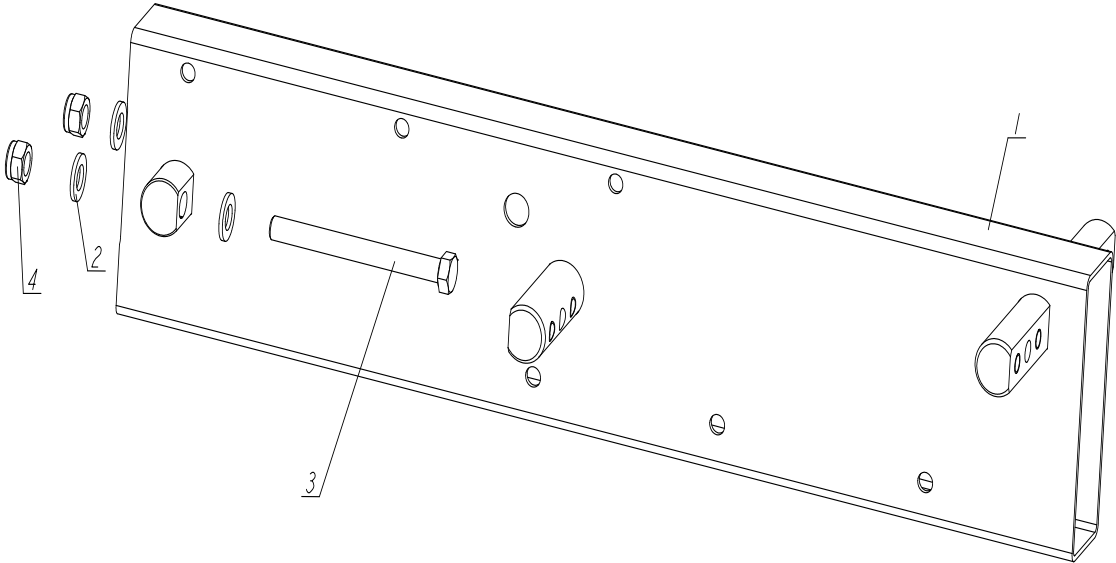

REF	DESCRIPTION (◆ indicates parts available in assemblies only)	PART #	QTY
-	EXTENSION, MAST TRACK FRONT - COMPLETE	538807	1
1	TUBE, MAST TRACK EXTENSION	538809-1	1
2	WASHER, 13 FLAT ZINC	F81056-1	4
3	BOLT M12X120 8.8 FE/ZN5	F81004-38	2
4	NUT, M12 8 HEX NYLON ZINC LOCK	F81034-2	2

2.13 Additional Bed Frame Sections with Outrigger Legs

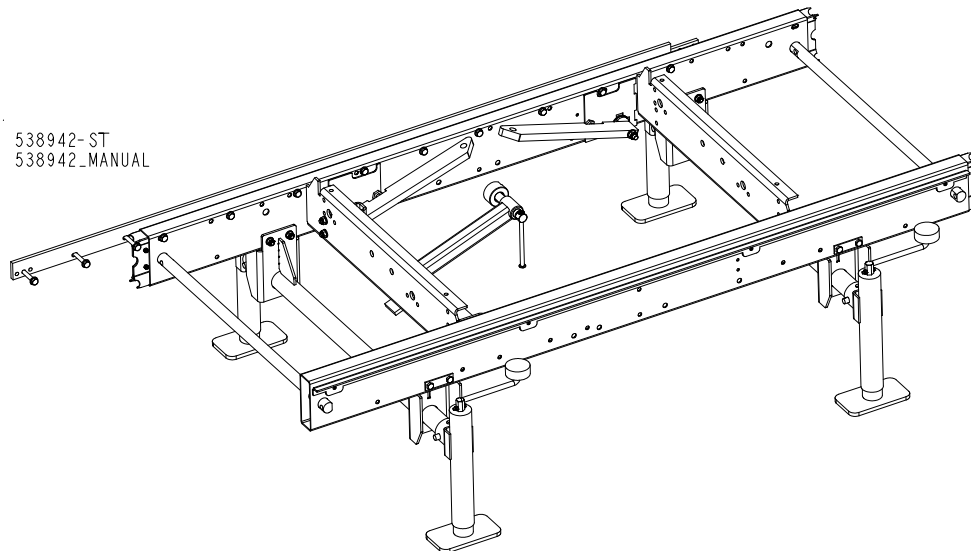
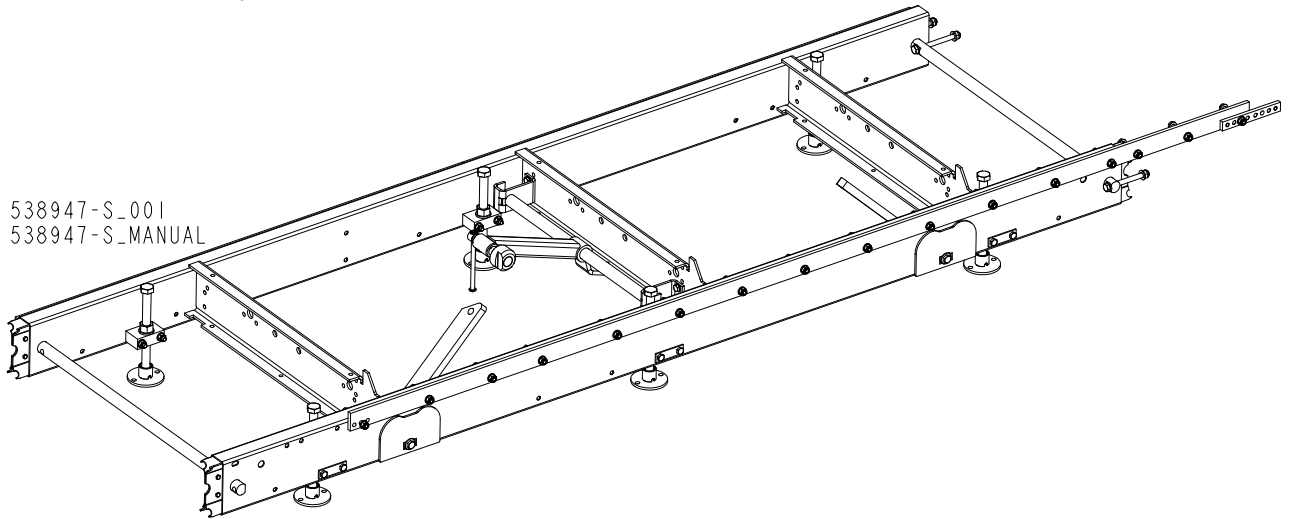
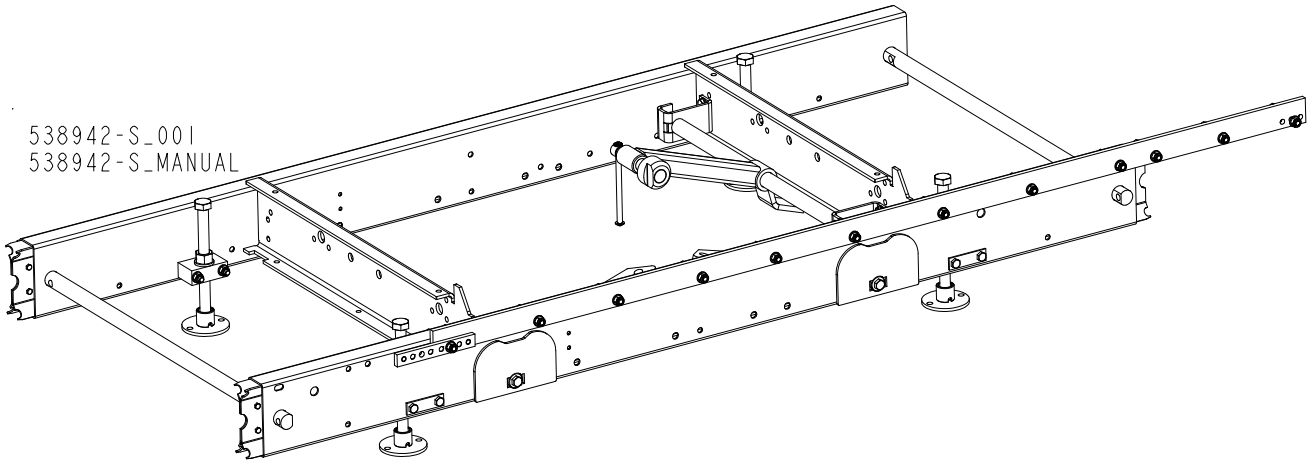

REF.	DESCRIPTION (◆ Indicates Parts Available In Assemblies Only)	PART #	QTY
	BED SECTION, UNIVERSAL S-TYPE, 1950MM SERVICE	538942-S	1
	BED SECTION, UNIVERSAL M-TYPE, 2700MM SERVICE	538947-S	1
	BED SECTION, UNIVERSAL S-TYPE, 1950MM SERVICE	538942-ST	1

2.14 Log Loading Ramp Assembly 097977

097977_001
097977

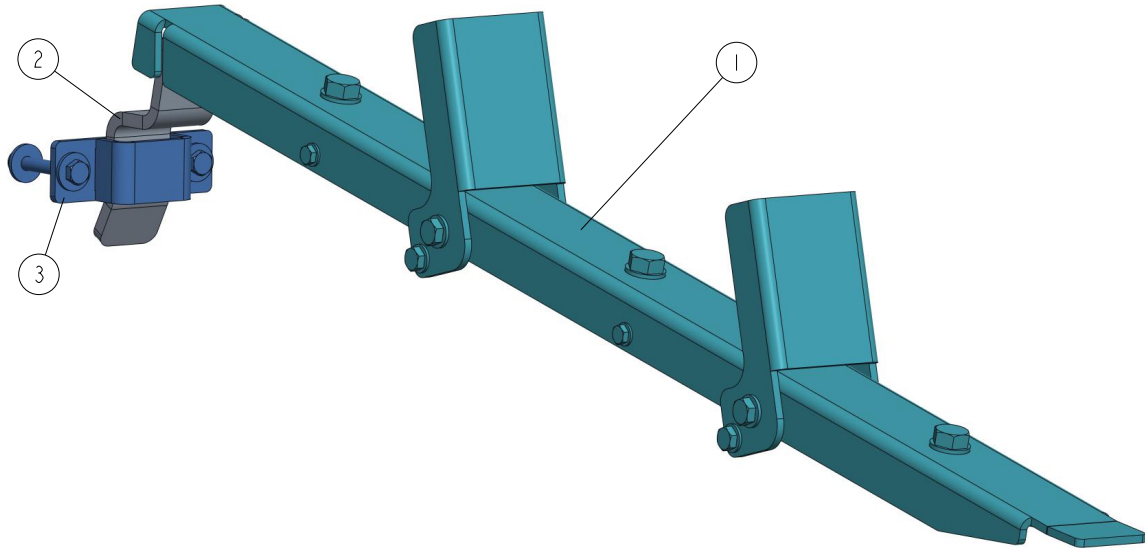

REF	DESCRIPTION (◆ indicates parts available in assemblies only)	PART #	QTY	
-	RAMP ASSEMBLY, LOG LOADING, LT15 COMPL.	097977	1	
1	RAMP ASSEMBLY, LOADING See Section 2.15	097483	1	
2	BRACKET, LT15 RAMP ZINC-PLATED	097976-1	1	
3	BRACKET, LT15 RAMP - COMPLETE See Section 2.16	507518	1	

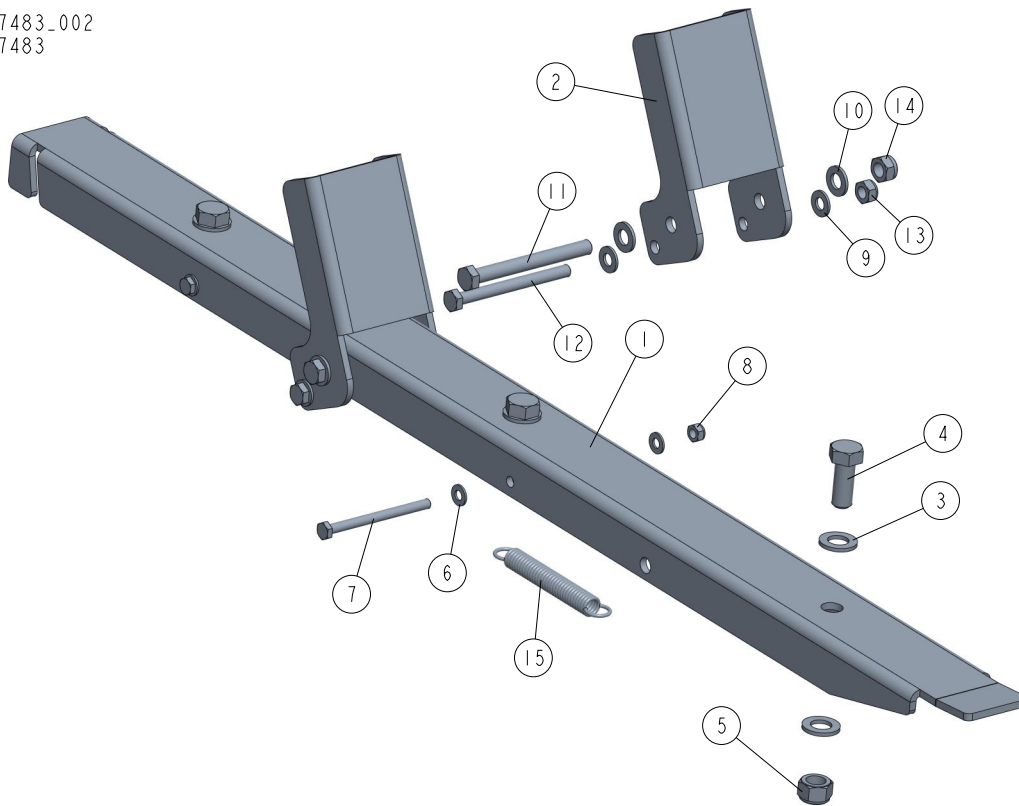
2.15 Loading Ramp Assembly 097483¹097483_002
097483

REF	DESCRIPTION (◆ indicates parts available in assemblies only)	PART #	QTY
-	RAMP ASSEMBLY, LOADING	097483	1
1	PLATE, LT10 LOADING RAMP - MAIN	097481-1	1
2	BRACKET, LOG LOADING STOP	097482-1	2
3	WASHER, 17 SPLIT LOCK ZINC	F81058-1	6
4	BOLT, M16X40-8.8 HEX HEAD FULL THREAD ZI	F81006-13	3
5	NUT, M16-8 HEX NYLON ZINC LOCK	F81036-2	3
6	WASHER, 8,4-FLAT ZINC	F81054-1	4
7	BOLT, M8X100-8.8 HEX HEAD ZINC	F81002-23	2
8	NUT, M8-8-B HEX NYLON ZINC LOCK	F81032-2	2
9	WASHER, 10.5 FLAT ZINC	F81055-1	4
10	WASHER, 13 FLAT ZINC	F81056-1	4
11	BOLT, M12X115-8.8-B HEX HEAD ZINC	F81004-33	2
12	BOLT, M10X110-8.8 HEX HEAD ZINC	F81003-43	2
13	NUT M10 ZC 8 NYLOCK DIN 982 ISO 7040	F81033-1	2
14	NUT, M12-8 HEX NYLON ZINC LOCK	F81034-2	2
15	SPRING, N1.9XN14.2X104	091865	2

1.(2x097483) included in assembly 586967

2.16 Ramp Bracket 507518

507518_001
507518

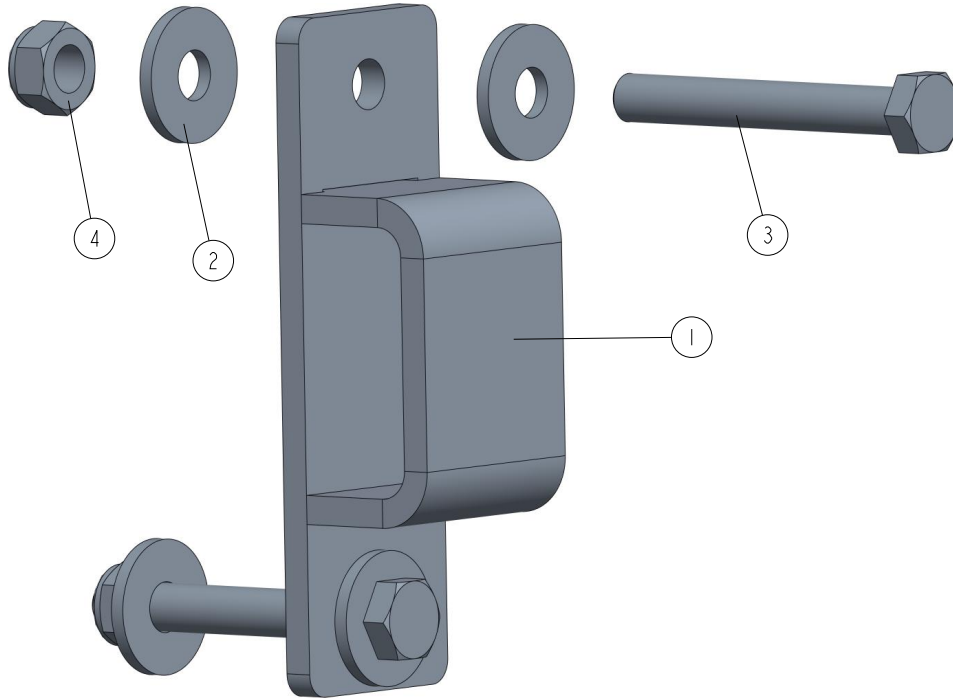

REF	DESCRIPTION (◆ indicates parts available in assemblies only)	PART #	QTY	
-	BRACKET, LT15 RAMP - COMPLETE	507518	1	
1	BRACKET WELDMENT, LT15 RAMP	507517-1	1	
2	WASHER 10,5 ZC FENDER DIN 9021 ISO 7093	F81055-6	4	
3	BOLT, M10X75-8.8-FE/ZN5 PN-M/82101	F81003-15	2	
4	NUT M10 ZC 8 NYLOCK DIN 982 ISO 7040	F81033-1	2	

3 BLADE GUIDE ROLLERS & ARM

Blade Guide Assembly, Idle Side

SECTION 3 BLADE GUIDE ROLLERS & ARM

3.1 Blade Guide Assembly, Idle Side

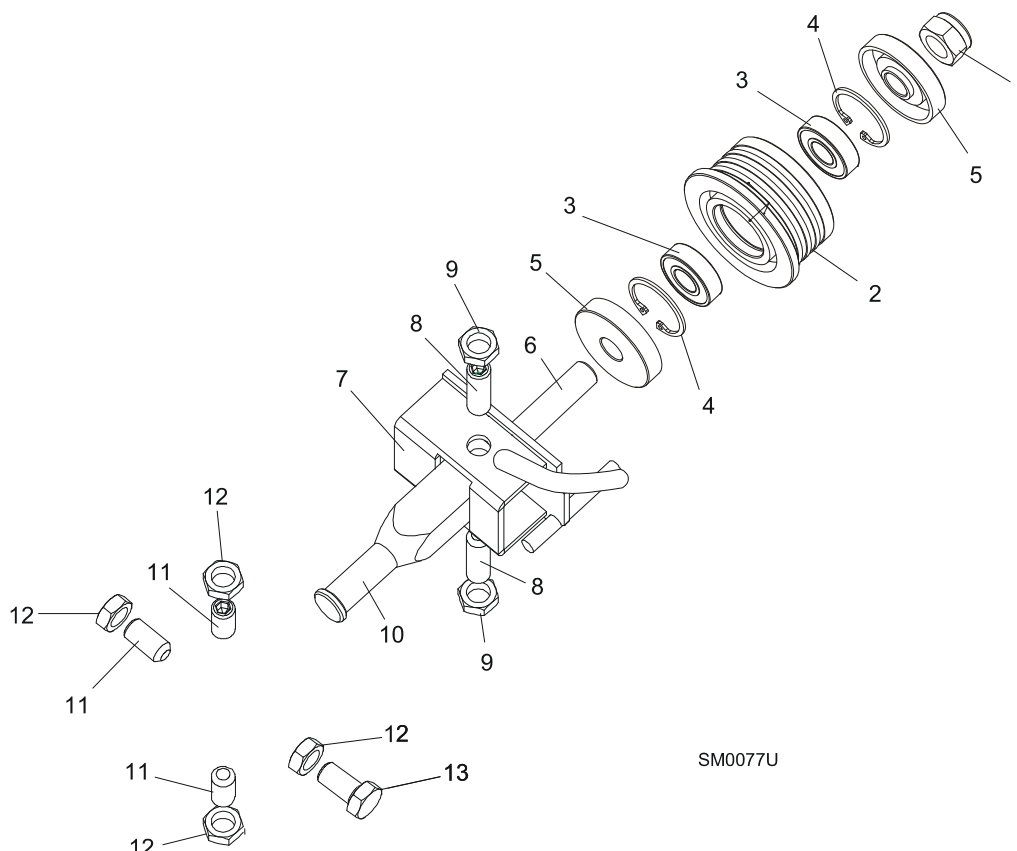

REF.	DESCRIPTION (◆ Indicates Parts Available In Assemblies Only)	PART #	QTY	
	BLADE GUIDE ASSEMBLY, IDLE SIDE	094683	1	
	Roller Assembly, Standard Blade Guide	087887	1	
1	Nut, M12-8 Hex Nylon Lock	F81034-2	1	
2	Roller, Narrow Blade Guide	087889	1	◆
3	Bearing, 6001 2RSR FAG	087893	2	
4	Ring, W28 Inside Retaining	F81090-9	1	
5	Washer, Zinc-plated Spacer	087891-1	2	
6	Shaft, Standard Blade Guide Roller Zinc	087763-1	1	
7	Bracket Weldment, Idle Side Blade Guide	094681-1	1	
8	Screw, M10x1x40 DIN 913 A2-70 Stainless Steel Set	F81015-2	2	
9	Nut, M10x1-04-ST-A2 ISO 8675 Thin	F81033-10	2	
10	Shaft, Zinc-Plated Blade Guide Mount	088255-1	1	
11	SCREW, M10X1X25 DIN 913 STAINLESS STEEL SET	F81015-4	4	
12	NUT, M10x1-04-ST-A2 ISO 8675 THIN	F81033-10	4	

3.2 Blade Guide Assembly, Drive Side

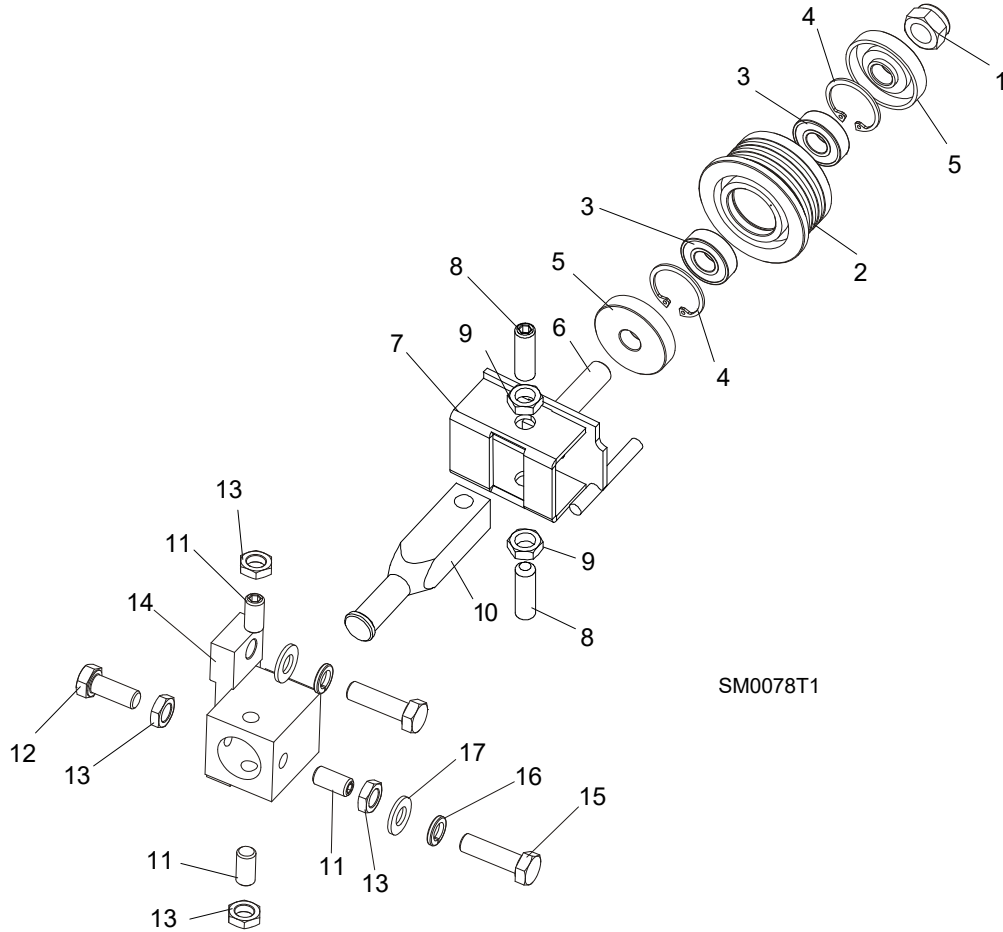

SM0078T1

REF.	DESCRIPTION (◆ Indicates Parts Available In Assemblies Only)	PART #	QTY	
	BLADE GUIDE ASSEMBLY DRIVE SIDE	094682	1	
	Roller Assembly, Standard Blade Guide	087887	1	
1	Nut, M12-8 Hex Nylon Lock Nut	F81034-2	1	
2	Roller, Narrow Blade Guide	087889	1	◆
3	Bearing, 6001 2RSR FAG	087893	2	
4	Ring, W28 Inside Retaining	F81090-9	1	
5	Washer, Zinc-plated Spacer	087891-1	2	
6	Shaft, Standard Blade Guide Roller Zinc	087763-1	1	
7	Bracket Weldment, Blade Guide	094679-1	1	
	Screw Kit, Blade Guide Adjustment w/Nuts (for two blade guide assemblies)	K09942	1	
8	Screw, M10x1x40 DIN 913 A2-70 Stainless Steel Set	F81015-2	2	
9	Nut, M10x1-04-ST-A2 ISO 8675 Thin	F81033-10	2	
10	Shaft, Zinc-Plated Blade Guide Mount	088255-1	1	
11	SCREW, M10X1X25 DIN 913 SET STAINLESS STEEL	F81015-4	3	
12	BOLT, M10X1X25 DIN 933 STAINLESS STEEL	F81003-28	1	

3**BLADE GUIDE ROLLERS & ARM***Blade Guide Assembly, Drive Side*

13	NUT, M10x1-04-ST-A2 ISO 8675 THIN	F81033-10	4	
14	TUBE, BLADE GUIDE MOUNT	087744	1	
15	BOLT, M10X35-8.8 HEX HEAD FULL THREAD ZINC	F81003-17	2	
16	WASHER, 10.2 SPLIT LOCK ZINC	F81055-2	2	
17	WASHER, 10.5 FLAT ZINC	F81055-1	2	

3.3 Blade Guide Roller Guard

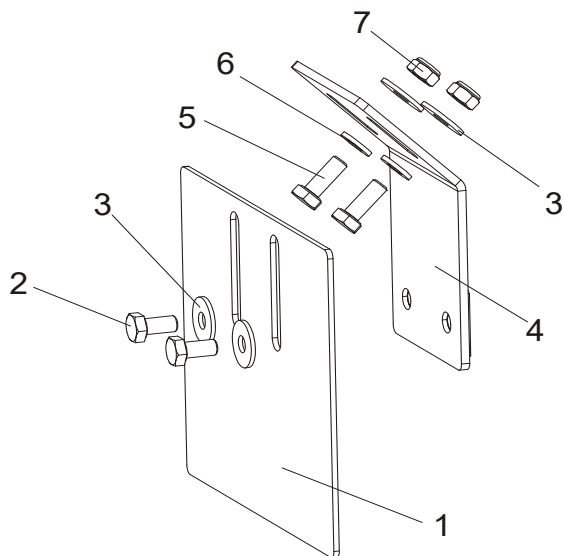

REF	DESCRIPTION (◆ Indicates Parts Available In Assemblies Only)	Part #	Qty	
1	GUARD, BLADE GUIDE ROLLER	092379-1	1	
2	BOLT, M6X12-8.8 HEX HEAD FULL THREAD ZINC	F81001-7	2	
3	WASHER, 6,5 SPECIAL FLAT ZINC	F81053-11	4	
4	BRACKET, ROLLER GUARD MOUNT	092378-1	1	
5	SCREW, M6X16 8.8 HEX HEAD FULL THREAD ZINC	F81001-15	2	
6	WASHER, 6,4 FLAT ZINC	F81053-1	2	
7	NUT, M6-8-B HEX NYLON ZINC LOCK	F81031-2	2	

3 BLADE GUIDE ROLLERS & ARM

Blade Guide Arm with Lever (094136)

3.4 Blade Guide Arm with Lever (094136)

094136_001_A
094136_MANUAL

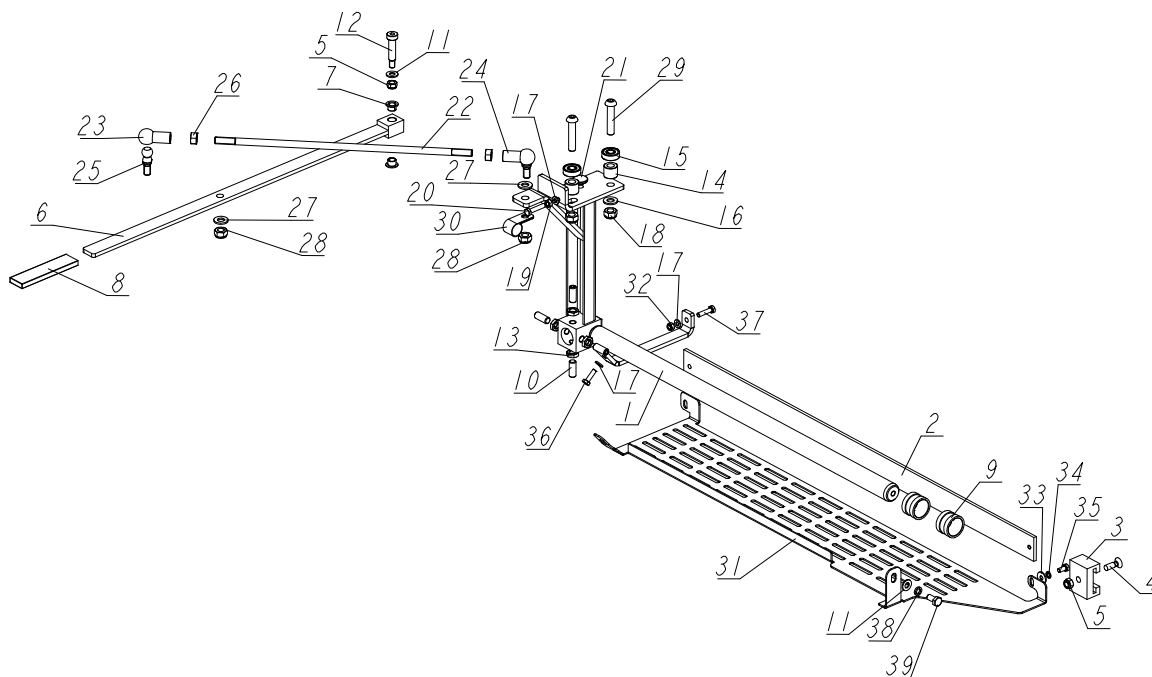

REF	DESCRIPTION (u indicates parts available in assemblies only)	PART #	QTY
-	BLADE GUIDE ARM W/LEVER - COMPLETE	094136	1
1	ARM WELDMENT, BLADE GUIDE	094138-1	1
2	BAR, BLADE GUARD	088306	1
3	BRACKET, BLADE GUIDE ARM GUIDE	088305	1
4	SCREW, M8X25-5.8 CROSS RECESSED COUNTERS	F81002-51	1
5	NUT, M8-8-B HEX NYLON ZINC LOCK	F81032-2	2
-	LEVER ASSEMBLY, BLADE GUIDE ARM ADJUSTME	531630	1
6	LEVER, BLADE GUIDE ARM ADJUSTMENT	531628-1	1
7	BEARING, TUF1 10.090 (CX)	099074	2
8	CAP, RRWA 91626 HANDLE END	086875	1
9	BUSHING, BLADE GUIDE	086684	2
10	SCREW, M10X1X25 DIN 913 STAINLESS STEEL	F81015-4	4
11	WASHER, 8.4 FLAT ZINC	F81054-1	2
12	BOLT, 10/M8X35 12.9 ISO7379 SHOULDER	F81003-63	1
13	NUT, M10X1-04-ST-A2 ISO 8675 THIN	F81033-10	4
14	BUSHING, 11/20-17 ZINC-PLATED	094255-1	2
15	BEARING, 6000.2RSR	087471	2
16	WASHER, 10.5 FLAT ZINC	F81055-1	2
17	WASHER, 6.4 FLAT ZINC	F81053-1	5
18	NUT, M10-8-B HEX NYLON ZINC LOCK	F81033-1	2

BLADE GUIDE ROLLERS & ARM*Blade Guide Arm with Lever (094136)***3**

REF	DESCRIPTION (u indicates parts available in assemblies only)	PART #	QTY	
19	NUT, M6 8 HEX ZINC	F81031-1	1	
20	BOLT, M6X30-8.8 HEX HEAD FULL THREAD ZIN	F81001-8	1	
21	BUSHING, BLADE GUIDE ARM	095936	1	
-	STUD BOLT ASSEMBLY, ARM LEVER CONNECTION	094204	1	
22	BOLT, ZINC-PLATED STUD	094203-1	1	
23	SEAT, BALL	093824	1	
24	SEAT, BALL	093824-1	1	
25	STUD, 16/SW-13 DIN71803-C BN486 BALL	093823	2	
26	NUT, M10-8-B-HEX ZINC	F81033-3	2	
27	WASHER, 10.5 FLAT ZINC	F81055-1	2	
28	NUT, M10-8-B HEX NYLON ZINC LOCK	F81033-1	2	
29	BOLT, M10X50-8.8 HEX HEAD FULL THREAD ZI	F81003-131	2	
30	CLAMP, 5/8 EMT COATED	010748	1	
31	GUARD, BOTTOM	525592-1	1	
32	NUT, M6-8-B HEX NYLON ZINC LOCK	F81031-2	2	
33	WASHER, 6.5 SPECIAL FLAT ZINC	F81053-11	1	
34	WASHER, Z 6.1 SPLIT LOCK	F81053-3	1	
35	BOLT, M6X12-8.8 HEX HEAD FULL THREAD ZIN	F81001-7	1	
36	BOLT, M6X20 8.8 HEX HEAD FULL THREAD ZIN	F81001-2	1	
37	BOLT, M6X25-5.8 HEX HEAD FULL THREAD ZIN	F81001-3	1	
38	WASHER 8,2 SPLIT LOCK ZINC	F81054-4	1	
39	BOLT, M8X16 -8.8-B HEX HEAD FULL THREAD	F81002-20	1	

SECTION 4 BLADE WHEELS & TENSIONER

4.1 Blade Wheel Assembly, Drive Side

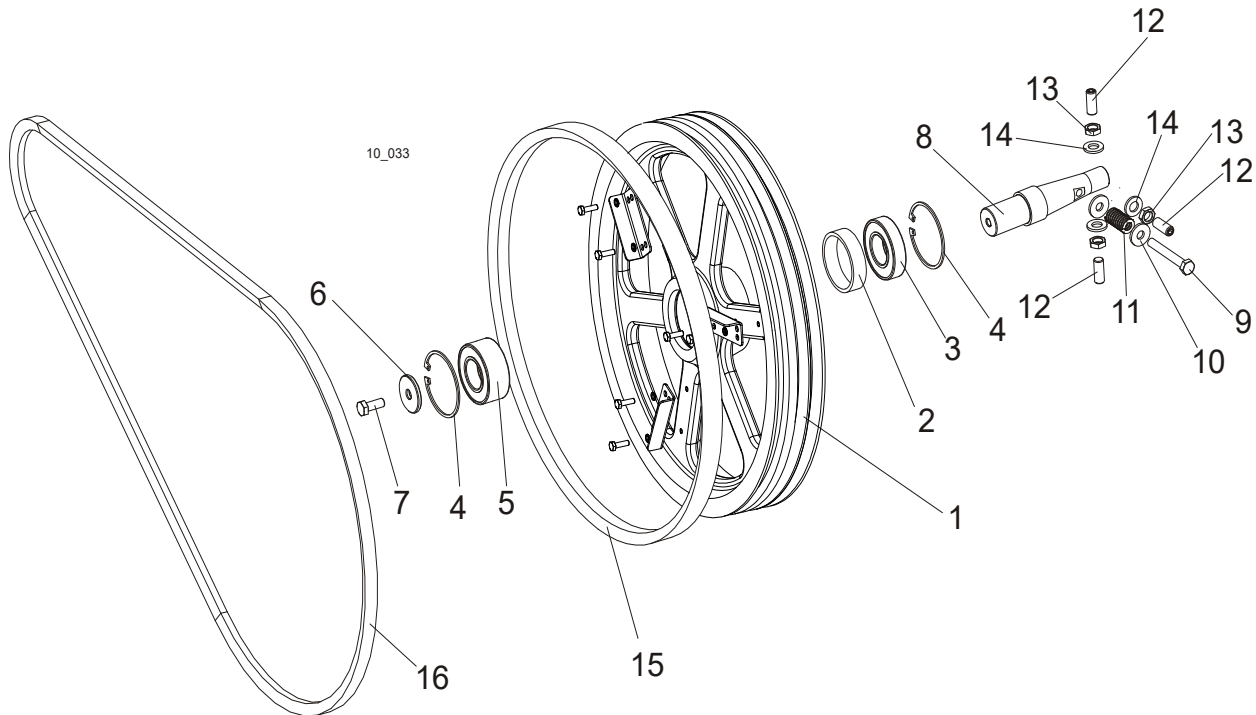

REF.	DESCRIPTION (◆ Indicates Parts Available In Assemblies Only)	PART #	QTY
	WHEEL ASSEMBLY, DRIVE SIDE BLADE	550620	1
1	BLADE WHEEL, DRIVE SIDE	090646-1	1
2	BUSHING, SPACER	096778	1
3	BEARING, 6207 2RS 35X72X17 FAG	014811	1
4	RING, W72 INSIDE RETAINING	F81090-4	2
5	BEARING, 3207B, 2RSR TVH FAQ	092005	1
6	WASHER, DRIVE SIDE BLADE WHEEL	092006	1
7	SCREW, M10X25-8.8 HEX HEAD FULL THREAD ZINC	F81003-11	1
8	SHAFT, DRIVE SIDE BLADE WHEEL	093850	1
9	BOLT, M10X75-8.8 HEX HEAD ZINC	F81003-15	1
10	WASHER, 10.5 SPECIAL FLAT ZINC	F81055-6	2
11	SPRING, 19X38 COMPRESSION	034430	1
12	SCREW, M12X1,25X30 DIN913 SET STAINLESS STEEL	F81016-1	3
13	WASHER, 13 FLAT ZINC	F81056-1	3
14	NUT, M12X1.25 DIN439 THIN STAINLESS STEEL	F81034-9	3
15	V-BELT, B57	P04185-3	1
16	DRIVE BELT, BX81	014819	1

4.2 Wide Blade Wheel Assembly, Drive Side, E15 Motor

LT15SCS3EH15EP-E_001_C
 LT15SCS3EH15EP-E_MANUAL

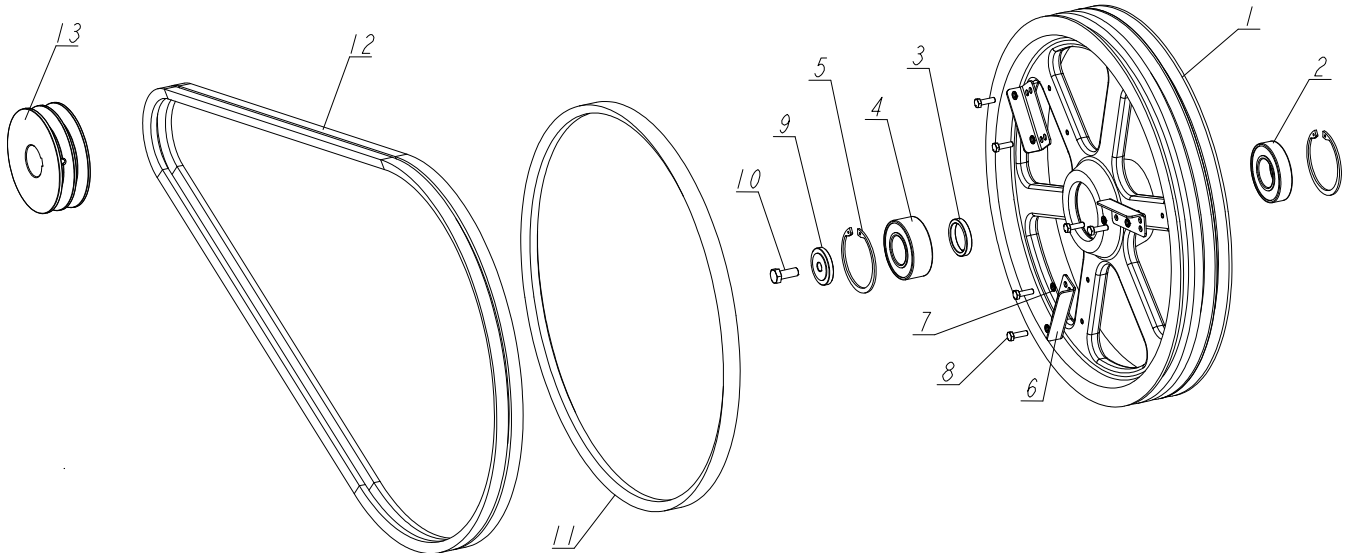

REF.	DESCRIPTION (◆ Indicates Parts Available In Assemblies Only)	PART #	QTY
-	BLADE WHEEL, DRIVE SIDE - COMPLETE	550620	1
1	WHEEL, LT20 DRIVE SIDE	090646-1	1
2	BEARING, 6207 -2RS1 SKF	014811	1
3	BUSHING, SPACER	096778	1
4	BEARING, 3207B.2RSR.TVH "FAG"	092005	1
5	RING, W72 INSIDE RETAINING	F81090-4	2
6	WING	097808-1	3
7	WASHER, Z 6.1 SPLIT LOCK ZINC	F81053-3	6
8	BOLT, M6X20 8.8 HEX HEAD FULL THREAD ZINC	F81001-2	6
9	WASHER, CLAMPING	092006	1
10	BOLT, M10X25 8.8 HEX HEAD FULL THREAD ZINC	F81003-11	1
11	BELT, B-57	P04185-2	1
12	V-BELT, 2BX81	014819-2	1
13	PULLEY, E15 MOTOR 2-GROOVE	091560	1

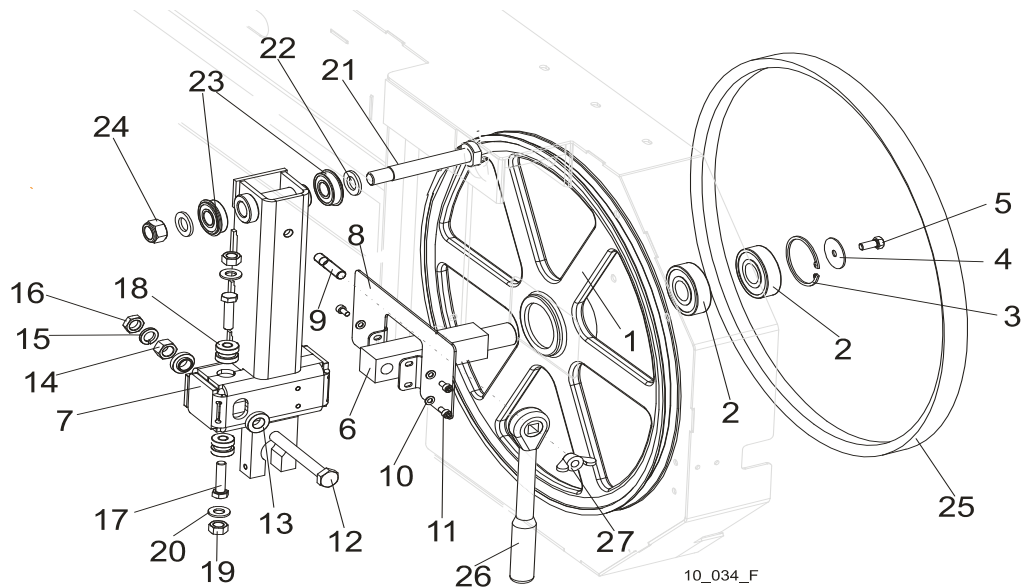
4.3 Blade Wheel Assembly, Idle Side

REF.	DESCRIPTION (◆ Indicates Parts Available In Assemblies Only)	PART #	QTY
	WHEEL ASSEMBLY, IDLE SIDE BLADE	A08218	1
1	WHEEL ASSEMBLY, 18.62" BLADE IDLE SIDE	P08125	1
2	BEARING, 6305 2RS NSK IDLE SIDE WHEEL	P08066	2
3	RING, 2 7/16" INSIDE RETAINING	F04254-21	1
	HOUSING, LT10 & LT15 IDLER SHAFT, COMPLETE	100180	1
4	WASHER, IDLE SIDE WHEEL RETAINING	093854-1	1
5	BOLT, M8X25-8.8-B HEX HEAD FULL THREAD ZINC	F81002-5	1
6	SHAFT, IDLE SIDE BLADE WHEEL (METRIC)	096045	1
	HOUSING, IDLER SHAFT COMPLETE	508145	1
7	HOUSING, IDLER SHAFT WELDED/PAINTED	508144-1	1
8	COVER, HOUSING, IDLER SHAFT COMPLETE PAINTED	508128-1	1
9	BOLT M10X35-8.8	F81003-9	1
10	WASHER, 5.3 FLAT ZINC	F81052-1	3
11	SCREW, M5x10 DIN912 A2-70 HEX SOCKET HEAD	F81000-23	3
12	BOLT, M12X1,25X100-8.8 HEX HEAD FULL THREAD ZINC	F81004-41	1
13	WASHER, FLANGED ZINC-PLATED	086769-1	2
14	NUT, M12X1,25 -8 HEX ZINC	F81034-8	1
15	WASHER, 12.2 SPLIT LOCK ZINC	F81056-2	1
16	NUT, M12x1.25 DIN439 THIN STAINLESS STEEL	F81034-5	1
17	BOLT, M10 X 40-8.8 HEX HEAD FULL THREAD ZINC	F81003-16	2
18	BUSHING, M10 IDLER SHAFT HOUSING	086987	2
19	NUT, M10-8-B HEX HEAD ZINC	F81033-3	2
20	WASHER, 10.5 FLAT ZINC	F81055-1	2
21	PIN, IDLER ARM MOUNT	086404	1
22	WASHER, 17 FLAT ZINC	F81058-1	2
23	BEARING, 6203-2RS NR NSK W/SNAP RING	086395	2
24	NUT, M16-8 HEX NYLON ZINC LOCK	F81036-2	1
25	V-BELT, B57	P04185-3	1
26	WRENCH, BLADE TENSION	091620	1
27	NUT, M10 WING	F81033-8	1

4.4 Blade Tensioner Assembly

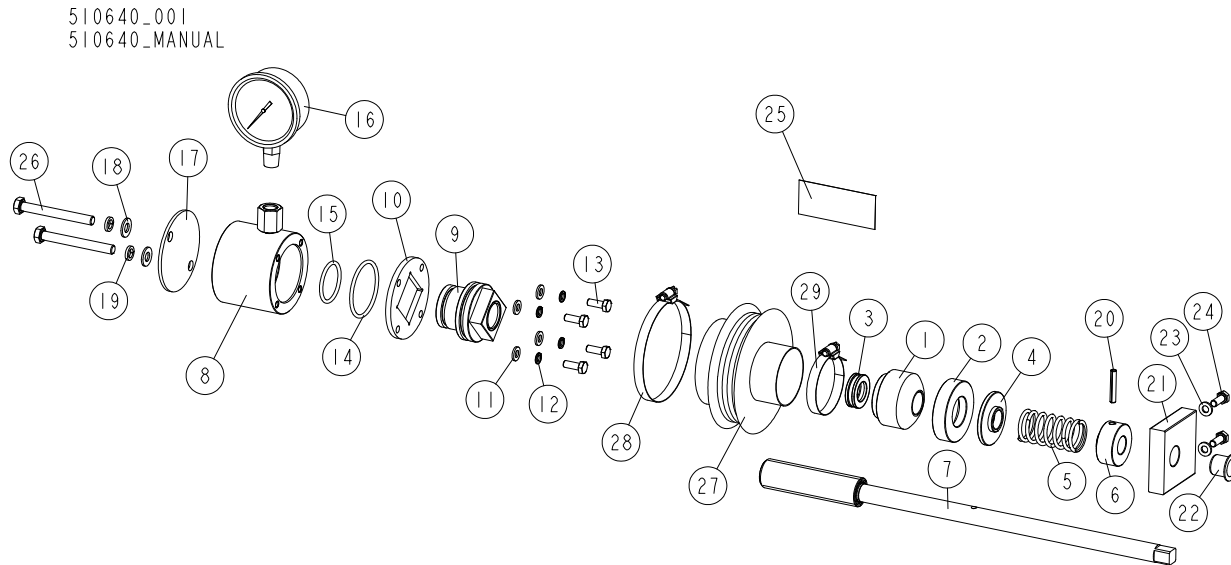

REF	DESCRIPTION (u indicates parts available in assemblies only)	PART #	QTY
-	COMPLETE BLADE TENSIONER	510640	1
1	HOUSING, BALL THRUST BEARING	510635	1
2	SOCKET, BEARING HOUSING	510634-1	1
3	BEARING, 51103. BALL THRUST	086675	1
4	WASHER	510633-1	1
5	SPRING, 60X23X3	088992	1
6	BUSHING, BLADE TENSIONER SCREW	510636-1	1
7	SCREW, BLADE TENSIONER ZINC-PLATED	510650-1	1
-	CYLINDER ASSEMBLY	510641	1
8	CYLINDER ASSEMBLY WITH REDUCTION	550762-1	1
9	PISTON	510638	1
10	PLATE, CYLINDER	510490-1	1
11	WASHER, 6.4 FLAT ZINC	F81053-1	4
12	WASHER, Z 6.1 SPLIT LOCK	F81053-3	4
13	BOLT, M6X16-5.8 HEX HEAD FULL THREAD ZIN	F81001-15	4
14	O-RING, 46.2X3	510646	1
15	O-RING, 32.2X3	510647	1
16	GAUGE, 3000PSI/200 BAR OIL PRESSURE	505176	1
17	COVER, TENSIONER	550761-1	1
18	WASHER, 8.4 FLAT ZINC	F81054-1	2
19	WASHER 8,2 SPLIT LOCK ZINC	F81054-4	2
20	PIN 5X30 ROLL	F81044-21	1
21	BLOCK, TENSIONER HANDLE MOUNT	096730	1
22	BUSHING, GFM-1618-17	089589	1
23	WASHER, 6.4 FLAT ZINC	F81053-1	2
24	BOLT, M6X16-5.8 HEX HEAD FULL THREAD ZIN	F81001-15	2
25	DECAL, BLADE TENSION INDICATOR ADJUSTMEN	510643	1

4**BLADE WHEELS & TENSIONER***Blade Tensioner Assembly*

REF	DESCRIPTION (u indicates parts available in assemblies only)	PART #	QTY	
26	BOLT, M8X70-8.8 HEX HEAD ZINC	F81002-71	2	
-	BELLOWS, COMPLETE	515050	1	
27	BELLOWS	515051	1	
28	CLAMP, 70-80MM DIA.	F81095-5	1	
29	CLAMP, 40-60MM DIA.	F81095-4	1	

4.5 Motor

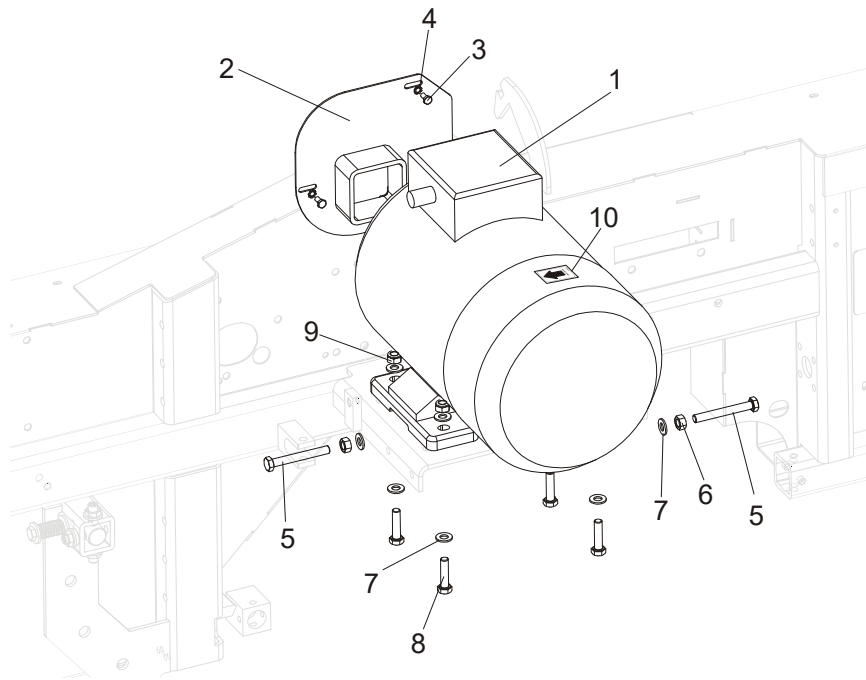

REF.	DESCRIPTION (◆ Indicates Parts Available In Assemblies Only)	PART #	QTY
1	MOTOR, 1LA7130-2AA60 5,5KW,400V,50HZ ELECTRIC	095785	1
2	MOTOR SHAFT COVER, E11 E15	095335-1	1
3	BOLT, M6X12-8.8 HEX HEAD FULL THREAD ZINC	F81001-7	3
4	WASHER, 6.4 STAR LOCK ZINC	F81053-2	3
5	BOLT, M10X80-8.8 HEX HEAD FULL THREAD ZINC	F81003-76	2
6	NUT, M10-8-B HEX ZINC	F81033-3	2
7	WASHER, 10.5 FLAT ZINC	F81055-1	10
8	BOLT, M10X40-8.8 HEX HEAD FULL THREAD ZINC	F81003-16	4
9	NUT, M10-8-B NYLON HEX ZINC LOCK	F81033-1	4
10	DECAL, ROTATION DIRECTION - 2925 RPM	S20097F ¹	1

¹ Included in 099419 - LT10 Pictographic Decal Kit.

4.6 Blade Brake

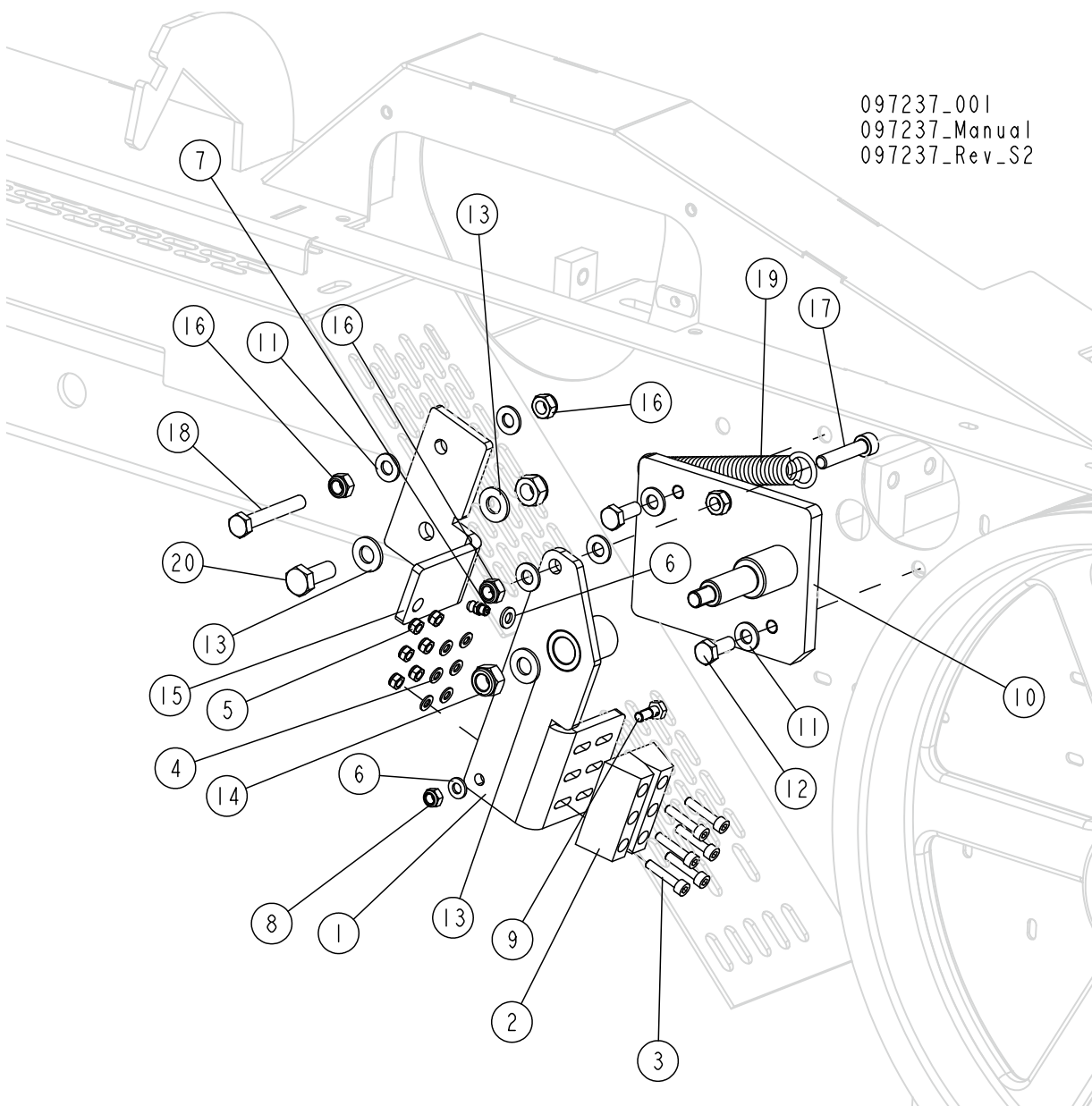

REF.	DESCRIPTION (* Indicates Parts Available In Assemblies Only)	PART #	QTY
	BRAKE, LT10 BLADE - COMPLETE	097367	1
1	ARM WELDMENT, BRAKE	097366-1	1
2	BLOCK, DRIVE BELT TENSIONER BRAKE	092111	2
3	SCREW, M5 x 25-5.8 HEX SOCKET HEAD CAP ZINC	F81000-7	6
4	WASHER, 5.3 FLAT ZINC	F81052-1	6
5	NUT, M5-8-Fe/Zn5 DIN985	F81030-2	6
6	WASHER, 6.4 FLAT ZINC	F81053-1	2
7	FITTING, M6 GREASE	086280	1
8	NUT, M6-8-B HEX NYLON ZINC LOCK	F81031-2	1
9	BOLT, THROTTLE CABLE CLAMP ZINC-PLATED	088120-1	1
10	PLATE WELDMENT, BRAKE	097363-1	1

REF.	DESCRIPTION (* Indicates Parts Available In Assemblies Only)	PART #	QTY	
11	WASHER, 8.4 FLAT ZINC	F81054-1	6	
12	BOLT,M8X20-5.8 HEX HEAD FULL THREAD ZINC	F81002-1	2	
13	WASHER, 10.5 FLAT ZINC	F81055-1	3	
14	NUT, M10-8-B HEX NYLON ZINC LOCK	F81033-1	2	
15	BRACKET, CABLE DRIVE BELT TENSIONER	097368-1	1	
16	NUT, M8-8-B HEX NYLON ZINC LOCK	F81032-2	4	
17	SCREW, M8X40-8.8 HEX SOCKET HEAD CAP ZINC	F81002-29	1	
18	BOLT, M8 X 55 8.8 HEX HEAD ZINC	F81002-8	1	
19	SPRING, FI 1,9 X FI 14,2 X 104	091865	1	
20	BOLT, M10 X 25 8.8 HEX HEAD FULL THREAD ZINC	F81003-31	1	
21	WASHER, LT15 DRIVE WHEEL ZINC	086286-1	1	
22	BOLT, M10X25-8.8 HEX HEAD FULL THREAD ZINC	F81003-11	1	

4.7 Blade Brake, E15 Motor

097237_001
097237_Manual
097237_Rev_S2

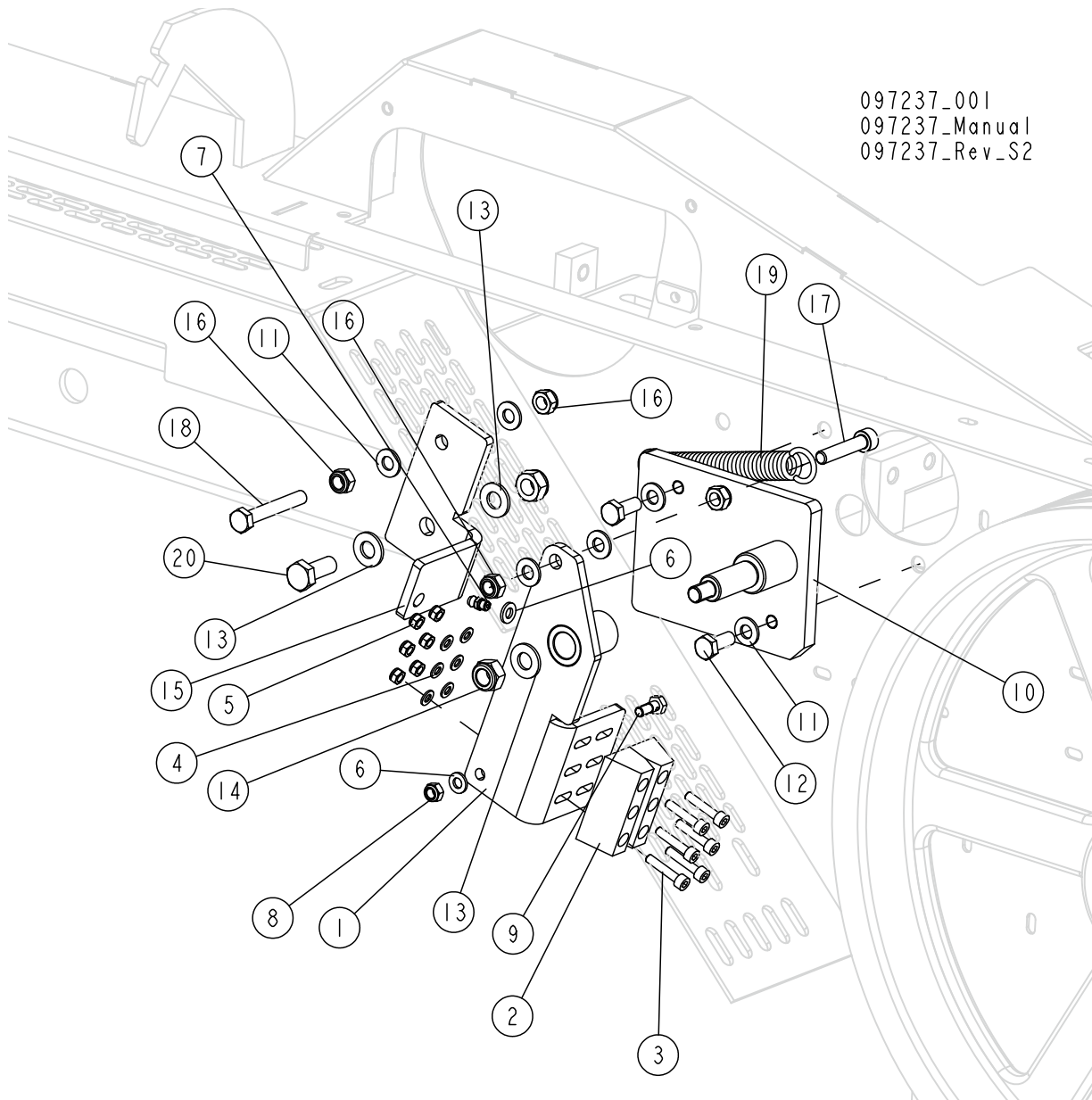

REF.	DESCRIPTION (* Indicates Parts Available In Assemblies Only)	PART #	QTY
-	BLADE BRAKE LT15SA	550424	1
1	ARM WELDMENT, BRAKE	550425-1	1
2	BLOCK, DRIVE BELT TENSIONER BRAKE XPZ	092111	2
3	SCREW M4X25 5.8-B FE/ZN5	F81011-50	4
4	WASHER, 4.3 FLAT ZINC	F81051-2	4
5	NUT, M4-8 HEX NYLON ZINC LOCK	F81029-1	4
6	WASHER, 6.4 FLAT ZINC	F81053-1	2
7	FITTING, M6 GREASE	086280	1
8	NUT, M6-8-B HEX NYLON ZINC LOCK	F81031-2	1
9	BOLT, THROTTLE CABLE CLAMP ZINC-PLATED	088120-1	1
10	PLATE WELDMENT, BRAKE	097363-1	1

BLADE WHEELS & TENSIONER*Blade Brake, E15 Motor***4**

REF.	DESCRIPTION (* Indicates Parts Available In Assemblies Only)	PART #	QTY	
11	WASHER, 8.4 FLAT ZINC	F81054-1	6	
12	BOLT, M8X20-8.8-B HEX HEAD FULL THREAD ZINC	F81002-4	2	
13	WASHER, 10.5 FLAT ZINC	F81055-1	3	
14	NUT, M10-8-B NYLON HEX ZINC LOCK	F81033-1	2	
15	BRACKET, CABLE DRIVE BELT TENSIONER	097368-1	1	
16	NUT, M8-8-B HEX NYLON ZINC LOCK	F81032-2	4	
17	SCREW, M8X40-8.8 HEX SOCKET HEAD CAP ZINC	F81002-29	1	
18	BOLT, M8 X 55 8.8 HEX HEAD ZINC	F81002-8	1	
19	SPRING, FI 1,9 X FI 14,2 X 104	091865	1	
20	BOLT, M10 X 25 8.8 HEX HEAD FULL THREAD ZINC	F81003-31	1	

SECTION 5 SAW HEAD

5.1 Blade Housing Cover

LT15SCS3G19SP-ESWP_002
LT15SCS3G19SP-ESWP_MANUAL

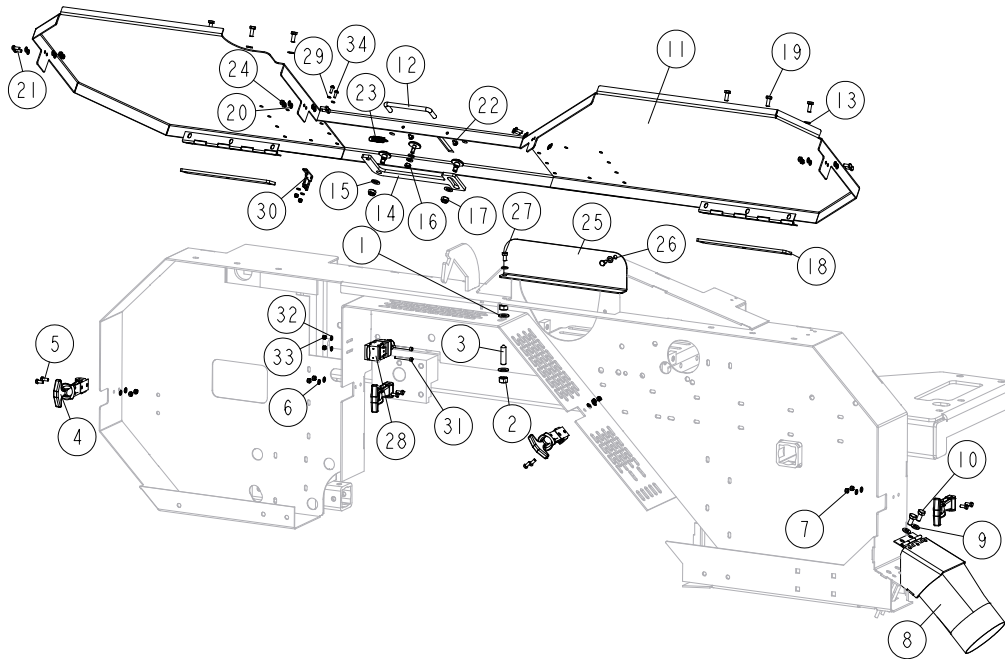

REF	DESCRIPTION (u indicates parts available in assemblies only)	PART #	QTY
1	WASHER, 10.5 FLAT ZINC	F81055-1	2
2	NUT, M10-8-B-HEX ZINC	F81033-3	2
3	SCREW, M10 X 40-45H HEX SOCKET SET CONE	F81003-61	1
4	LATCH, FLEXIBLE DRAW	014829	4
5	BOLT, M5X12 8.8 HEX HEAD FULL THREAD ZIN	F81000-5	8
6	WASHER, 5.3 FLAT ZINC	F81052-1	8
7	NUT, M5-8 DIN985 ZINC-PLATED	F81030-2	8
8	CHUTE WELDMENT, SAWDUST	100903-1	1
9	WASHER, 8.4 FLAT ZINC	F81054-1	2
10	BOLT, M8X16 -8.8-B HEX HEAD FULL THREAD	F81002-20	2
-	COVER, LT15 FRONT COMPLETE	098678	1
11	COVER WELDMENT, LT20 BLADE HOUSING	096776-1	1
12	HANDLE, BLADE HOUSING COVER	P08065	1
13	WASHER, 6.4 FLAT ZINC	F81053-1	8
14	PAWL, LOCKING	090643-1	1
15	WASHER, 8.4 FLAT ZINC	F81054-1	2
16	NUT, M6-8-B HEX NYLON ZINC LOCK	F81031-2	1
17	NUT, M8-8-B HEX NYLON ZINC LOCK	F81032-2	2
18	PLATE WELDMENT, COVER MOUNT	086701-1	1
19	BOLT, M6X16-5.8 HEX HEAD FULL THREAD ZIN	F81001-15	6

REF	DESCRIPTION (u indicates parts available in assemblies only)	PART #	QTY	
20	WASHER, 5.3 FLAT ZINC	F81052-1	16	
21	BOLT, M5X12 8.8 HEX HEAD FULL THREAD ZIN	F81000-5	8	
22	SCREW, #8-32X3/8, SELF-TAPPING	F05015-8	2	
23	SPRING, 1.6X12X38 EXTENSION	092208	1	
24	NUT, M5-8 DIN985 ZINC-PLATED	F81030-2	6	
25	COVER, SAW HEAD MOUNT	096788-1	1	
26	WASHER, 6.4 FLAT ZINC	F81053-1	2	
27	BOLT, M6X12-8.8 HEX HEAD FULL THREAD ZIN	F81001-7	2	
28	SWITCH, AZ17-11ZRK SAFETY 1	094232	1	
29	KEY, AZ17/170-B5 SAFETY SWITCH 2	094422	1	
30	KEY, AZ17/170-B5 SAFETY SWITCH 2	094422	1	
31	SCREW, M4X35 8.8 HEX SOCKET HEAD CAP ZIN	F81011-34	2	
32	WASHER, 4.3 FLAT ZINC	F81051-2	2	
33	NUT, M4-8 HEX NYLON ZINC LOCK	F81029-1	4	
34	SCREW, M4X12 5,8-B CROSS RECESSED PAN HE	F81011-43	2	

5.2 Water Lube Assembly

525794_001_A
525794_MANUAL

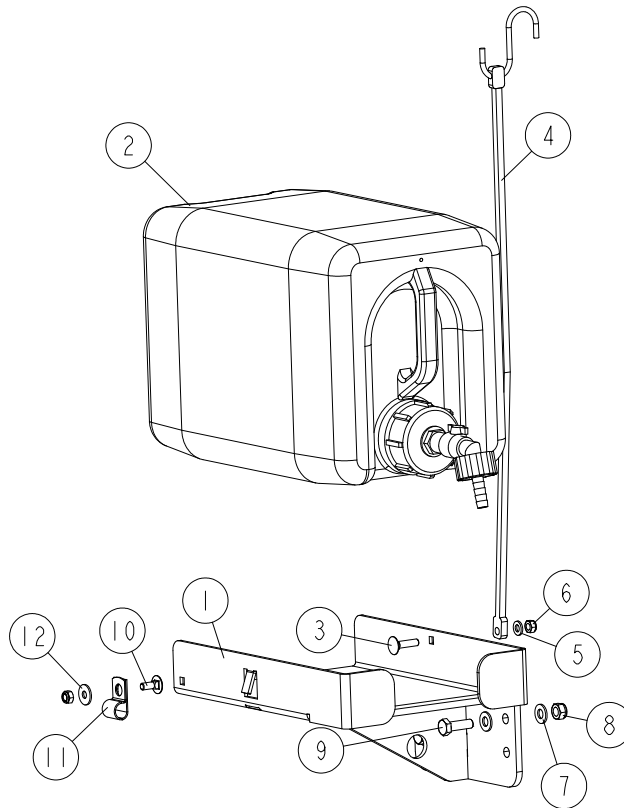

REF	DESCRIPTION (u indicates parts available in assemblies only)	PART #	QTY
-	BOTTLE ASSEMBLY, LT15SA/G14/E7/10/15 WAT	525794	1
1	TRAY, LT15/G14 WATER BOTTLE	525795-1	1
2	TANK, OIL See Section 5.3	550786	1
3	BOLT, M6X25-8.8 ZINC	F81001-20	1
4	STRAP, 15 RUBBER W/S HOOKS	P07461	1
5	WASHER, 6.4 FLAT ZINC	F81053-1	1
6	NUT, M6-8-B HEX NYLON ZINC LOCK	F81031-2	2
7	WASHER, 8.4 FLAT ZINC	F81054-1	6
8	NUT, M8-8-B HEX NYLON ZINC LOCK	F81032-2	3
9	BOLT, M8X25-8.8-B HEX HEAD FULL THREAD Z	F81002-5	3
10	BOLT, M6X16 -8.8 CARRIAGE ZINC	F81001-36	1
11	CLAMP, 1/2" EMT COATED	P07584	1
12	WASHER, FLAT ZINC	F81053-11	1

5.3 Oil Tank

550786_001
550786

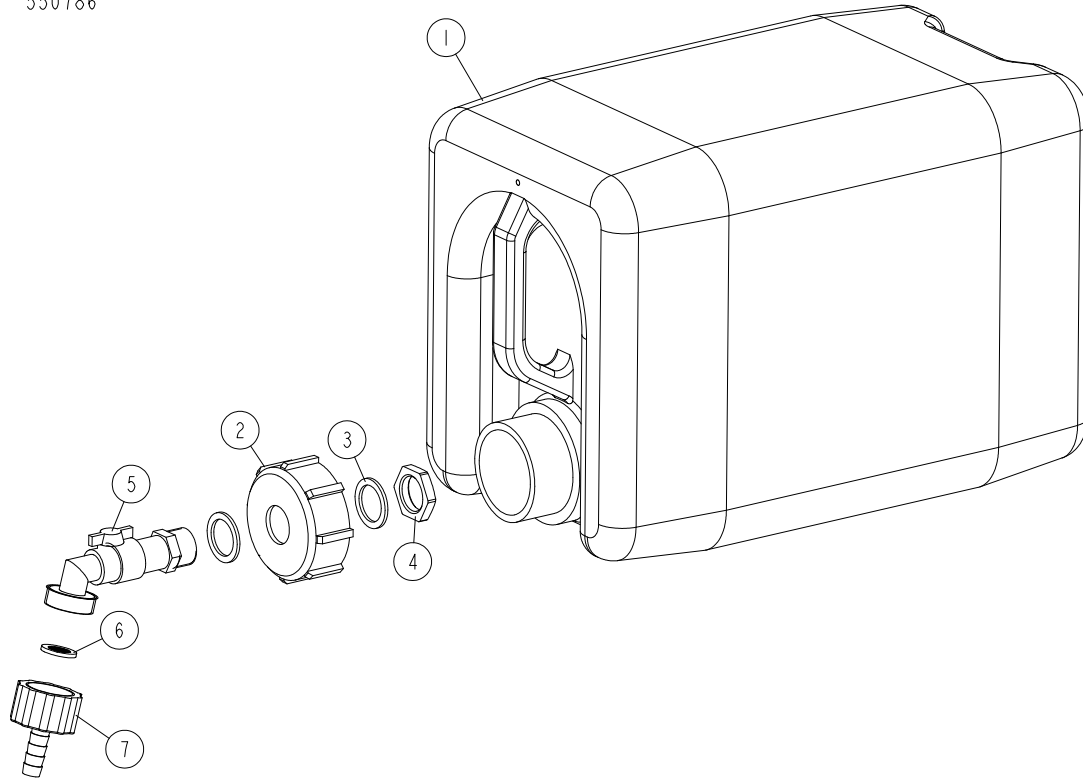

REF	DESCRIPTION (u indicates parts available in assemblies only)	PART #	QTY	
-	TANK, OIL	550786	1	
1	TANK, 10L OIL	711400	1	
2	NUT, BOTTLE	550785	1	
3	SEAL, 27X20X1.5 ESSENTRA 467673 RUBBER	550780	2	
4	NUT, 1/2 ESSENTRA 467615 GLAND	550779	1	
5	FITTING, WATER LUBE SHUTOFF VALVE	550776	1	
6	FILTER, WATER LUBE	550778	1	
7	FITTING, G3/4" X 10MM HOSE BARB	550777	1	

5.4 LT10 Saw Head Decals

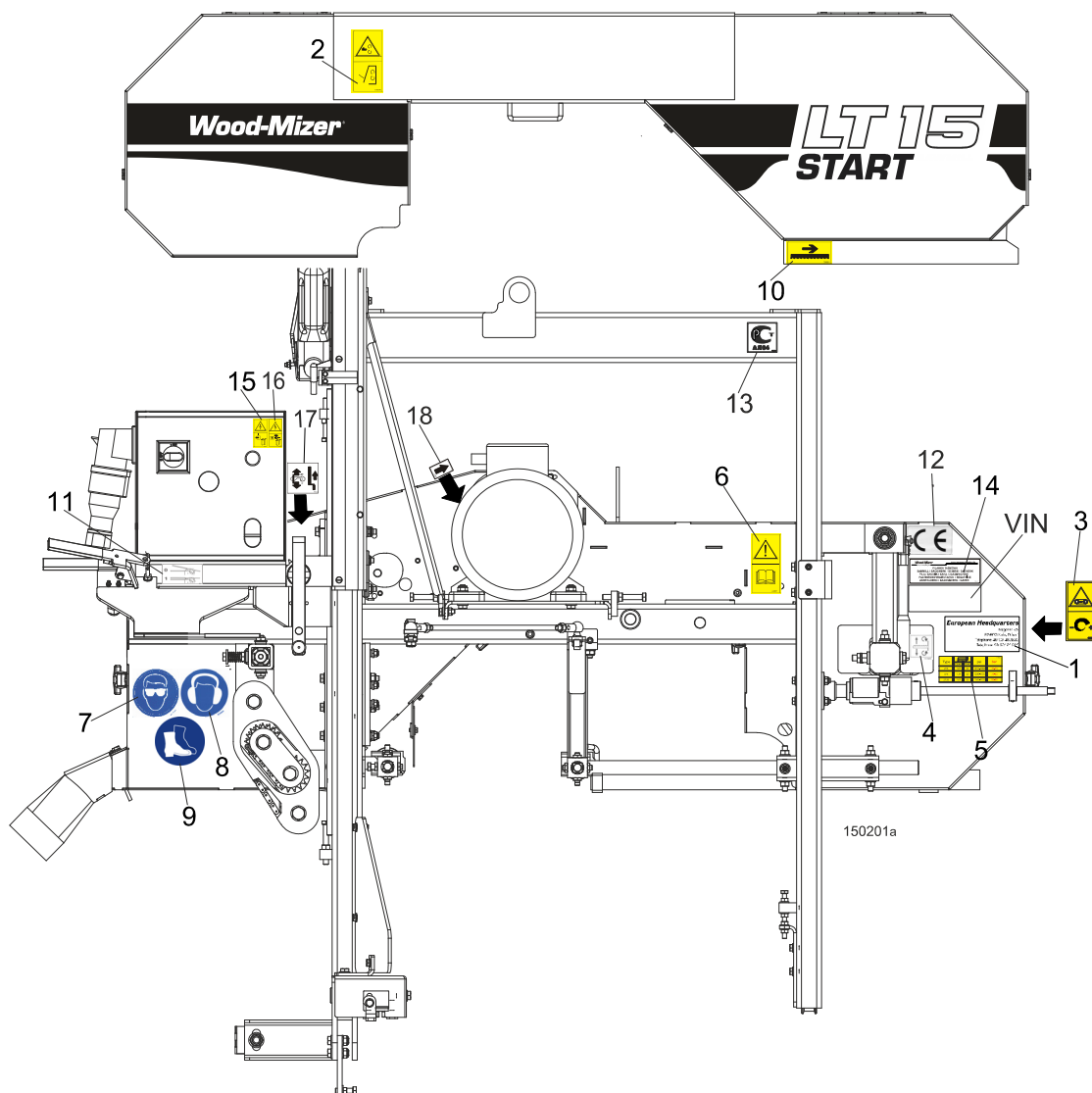

REF.	DESCRIPTION (◆ Indicates Parts Available In Assemblies Only)	PART #	QTY
	PICTOGRAPHIC DECAL KIT, LT10	099419	1
	DECAL, SAWMILL NAME	528776	1
1	DECAL, EUROPEAN HEADQUARTERS ADDRESS	015841	1
2	DECAL, SAWMILL COVERS CAUTION	099220	1
3	DECAL, BLADE TENSION (PICTOGRAM)	099219	1
4	DECAL, BLADE ALIGNMENT	P11789	1
5	DECAL, BLADE TENSION INDICATOR ADJUSTMENT	510643	1
6	DECAL, READ OPERATOR'S MANUAL (PICTOGRAM)	096317	1
7	DECAL, EYE PROTECTION WARNING (PICTOGRAM)	S12004G	1
8	DECAL, EAR PROTECTION WARNING (PICTOGRAM)	S12005G	1
9	DECAL, USE SAFETY BOOTS (PICTOGRAM)	501465	1
10	DECAL, BLADE MOVEMENT DIRECTION (PICTOGRAM)	096321	1
11	DECAL, SAFETY HANDLE	501477	1

12	DECAL, CE CERTIFIED SAWMILL (SMALL)	P85070	1	
13	DECAL, RUSSIAN SAFETY CERTIFICATION	099401	1	
14	DECAL, INTERNATIONAL SAWMILL NAME	501466	1	
15	DECAL, HIGH VOLTAGE INSIDE THE ELECTRIC BOX (PICTOGRAM)	096316	1	
16	DECAL, REMOVE THE PLUG BEFORE OPENING THE BOX (PICTOGRAM)	096319	1	
17	DECAL, POWER FEED SYSTEM ENGAGEMENT (PICTOGRAM)	099226	1	
18	DECAL, MOTOR REVOLUTIONS DIRECTION	S20097	1	

5.5 Control Box

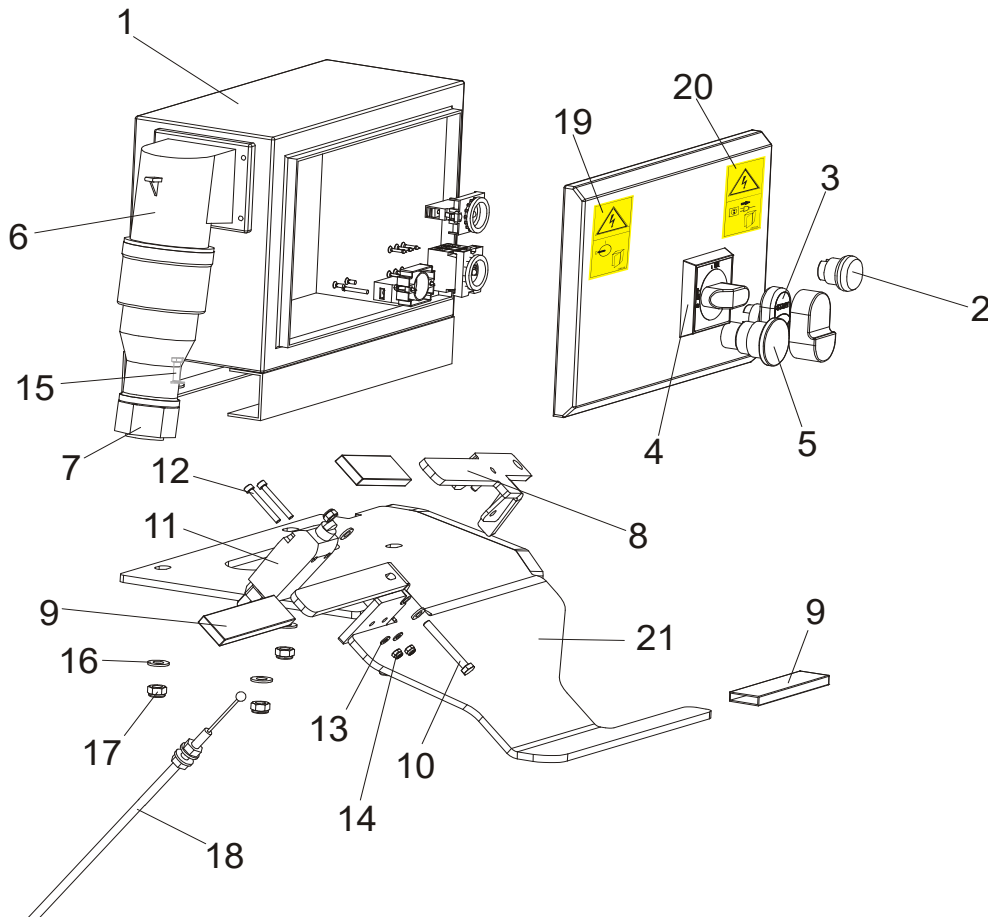

REF.	DESCRIPTION (◆ Indicates Parts Available In Assemblies Only)	PART #	QTY
	BOX, LT10 ELECTRIC	096001-M	1
	BOX, LT10 ELECTRIC (NORWEGIAN VERSION)	096001-M2	1
1	Box, Electric	527678	1
	Door, Electric box LT15SA	083543	1
2	Light, LPM LB7, White, Control	536919	1
3	Start/Stop Switch	535451-K	1
4	Switch, ABB OT16 F3	503541	1
	Knob, OHB S2A1 ABB Switch	502312-1	1
	Axle, OXS6160 ABB Switch	502312-2	1
5	Switch, Emergency Stop	535445-K	1
6	Plug, 16A 5P 778152-6 PCE	E85239	1
7	Socket, 16A 5P 2152-6TT PCE	E85240	1
8	HANDLE WELDMENT, BLADE ENGAGEMENT	097221-1	1
9	COVER, RRWA-91626-110 GRIP	086875	3
10	BOLT, M6X50-8.8 HEX HEAD ZINC	F81001-62	1
11	SWITCH, GLCB01C LIMIT	100910	1
12	SCREW, M4X35 -8.8 HEX SOCKED HEAD CAP ZINC	F81011-34	2
13	WASHER, 4.3 FLAT ZINC	F81051-2	2
14	NUT, M4-B HEX NYLON ZINC LOCK	F81029-1	2

15	BOLT, M8X25-8.8-B HEX HEAD FULL THREAD ZINC	F81002-5	4	
16	WASHER, 8.4 FLAT ZINC	F81054-1	8	
17	NUT, M8-8-B HEX NYLON ZINC LOCK	F81032-2	4	
18	CABLE, THROTTLE	089450	1	
19	DECAL, HIGH VOLTAGE INSIDE THE ELECTRIC BOX (PICTOGRAM)	096316	1	
20	DECAL, REMOVE THE PLUG BEFORE OPENING THE BOX (PICTOGRAM)	096319	1	
21	T-HANDLE, LT10	507386-1	1	

5.6 Guard Assembly 598105

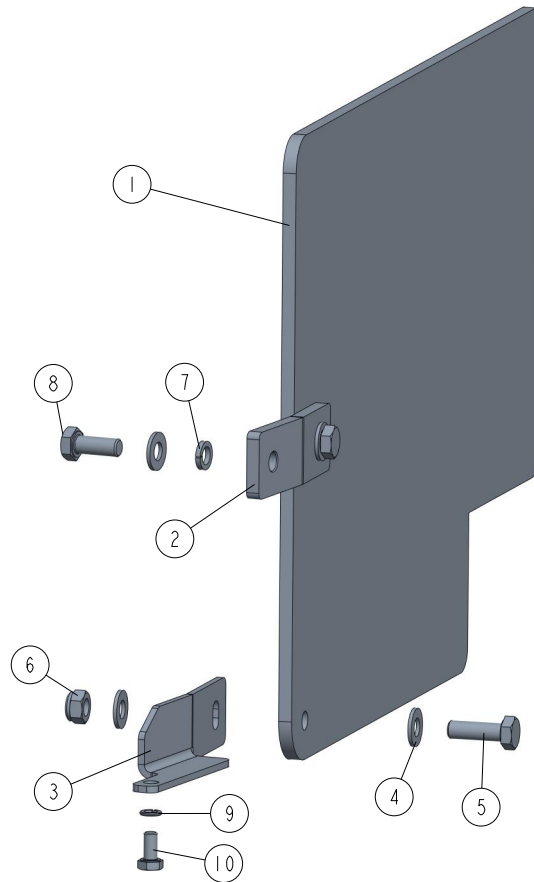
598105_001
598105

REF	DESCRIPTION (◆ indicates parts available in assemblies only)	PART #	QTY
-	GUARD ASSEMBLY	598105	1
1	PLATE, GUARD	598104	1
2	BRACKET, SIDE	086171-1	1
3	BRACKET, DOWN	598106-1	1
4	WASHER, 8.4 FLAT ZINC, WASHER, 8.4 FLAT,ZINC	F81054-1	5
5	BOLT, M8X25-8.8-B HEX HEAD FULL THREAD Z	F81002-5	2
6	NUT, M8-8-B HEX NYLON ZINC LOCK	F81032-2	2
7	WASHER, 8.2 SPLIT LOCK ZINC	F81054-4	1
8	BOLT, M8X20-8.8-B-HEX HEAD FULL THREAD Z	F81002-4	1
9	WASHER, Z 6.1 SPLIT LOCK ZINC	F81053-3	1
10	BOLT, M6X12 8.8 HEX HEAD FULL THREAD ZIN	F81001-7	1

SECTION 6 FEED SYSTEM

6.1 Track Rail, Rollers & Travel Pins

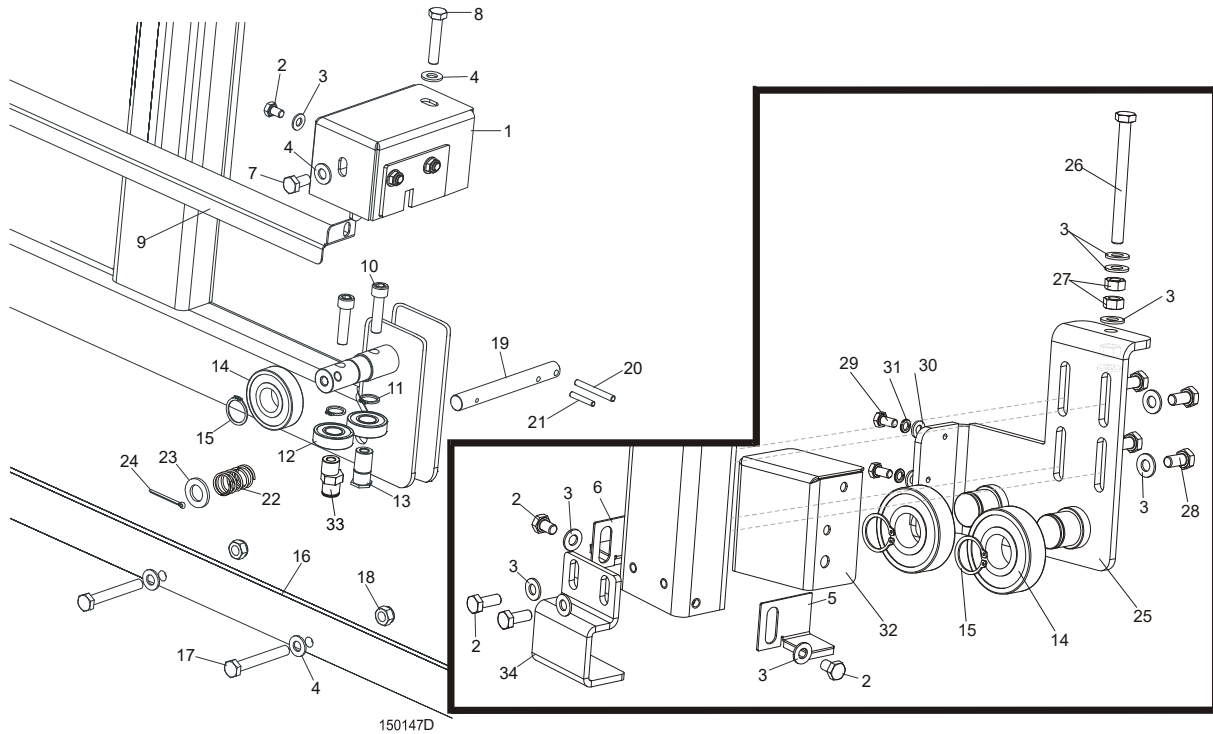

REF.	DESCRIPTION (◆ Indicates Parts Available In Assemblies Only)	PART #	QTY	
1	COVER ASSEMBLY, TRACK ROLLER	542800	2	
2	BOLT, M8X12-8.8 HEX HEAD FULL THREAD ZINC	F81002-6	6	
3	WASHER, 8.4 FLAT ZINC	F81054-1	14	
4	WASHER, 10.5 FLAT ZINC	F81055-1	13	
5	PLATE, RIGHT TRACK WIPER	086322	1	
6	PLATE, LEFT TRACK WIPER	086323	1	
7	BOLT, M10 X 20 5.8 HEX HEAD FULL THREAD ZINC	F81003-1	2	
8	BOLT, M10X50-8.8 HEX HEAD FULL THREAD ZINC	F81003-4	2	
9	COVER, MIDDLE TRACK	086745	1	
10	SCREW, M10X40 HEX SOCKET HEAD CAP ZINC	F81003-22	4	
11	RING, Z 17 OUTSIDE RETAINING	F81090-21	4	
12	BEARING, 6203-2RS ROLLING	086114	4	
13	SHAFT, SIDE BEARING MOUNT ZINC-PLATED	086645-1	2	
14	BEARING, 6305-2RS CX	085706	4	
15	RING, 25Z OUTSIDE RETAINING	F81090-22	4	
16	RAIL, LT15 1950 (LT15S3) TRACK ZINC-PLATED	094427-1	3	
	RAIL, LT15 2700 (LT15M2) TRACK ZINC-PLATED	538935-1	2	
17	BOLT, M10X75-8.8 HEX HEAD ZINC	F81003-15	9/13 ¹	
18	NUT, M10-8-B HEX NYLON ZINC LOCK	F81033-1	9/13 ²	

19	PIN, TRAVEL LOCK ZINC-PLATED	086743-1	1	
20	PIN, 6X50 ROLL ZINC	F81045-1	1	
21	PIN, 5 X 30 ROLL ZINC	F81044-21	1	
22	SPRING, 18X37X1.8 COMPRESSION ZINC-PLATED	087301	1	
23	WASHER, 17 FLAT ZINC	F81058-1	1	
24	PIN, 4 X 25 COTTER ZINC	F81043-2	1	
25	BRACKET, ROLLER	506703-1	1	
26	BOLT, M8X90-8.8 HEX HEAD FULL THREAD ZINC	F81002-16	1	
27	NUT, M8-8-B HEX ZINC	F81032-1	3	
28	BOLT, M8X16-8.8-B HEX HEAD FULL THREAD ZINC	F81002-20	4	
29	BRACKET MAST GUIDE	503768-1	1	
30	WASHER, 6.4 FLAT ZINC	F81053-1	2	
31	WASHER, Z 6.1 SPLIT LOCK ZINC	F81053-3	2	
32	COVER, ROLLER	501783-1	1	
33	SHAFT, E=3.3 ECCENTRIC ZINC-PLATED	531678-1	2	

¹ Number of bolts for one bed section.

² Number of nuts for one bed section.

6.2 Track Roller Cover Assembly

542800_001
542800_MANUAL

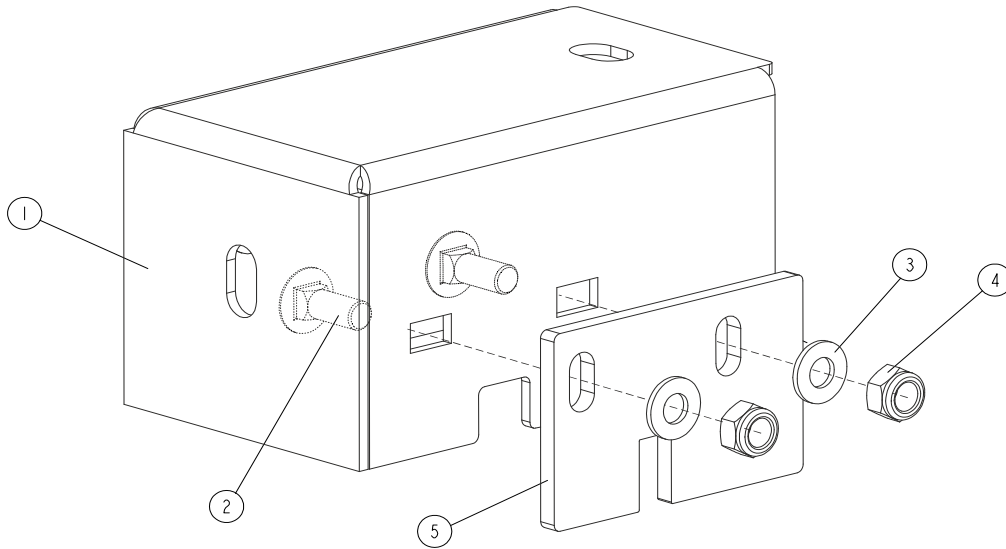

REF.	DESCRIPTION (◆ indicates parts available in assemblies only)	PART #	QTY	
	COVER ASSEMBLY, TRACK ROLLER	542800	2	
1	COVER, TRACK ROLLER	531664-1	1	
2	BOLT, M8x20-8.8 CARRIAGE ZINC	F81002-11	4	
3	WASHER, 8.4 FLAT ZINC	F81054-1	4	
4	NUT, M8-8-B HEX NYLON ZINC LOCK	F81032-2	4	
5	PLATE, TRACK WIPER	531670	2	

6.3 Track Rollers

506701_001
506701_MANUAL

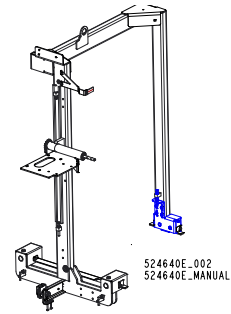
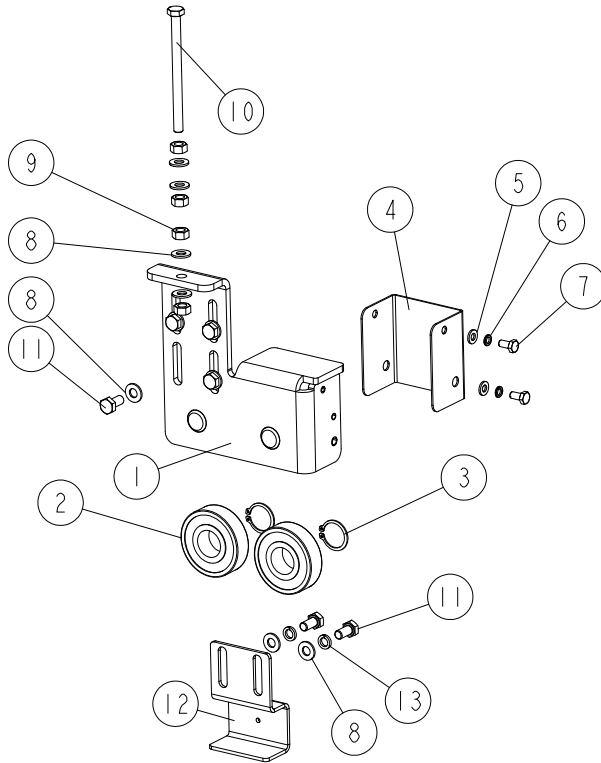

REF	DESCRIPTION (u indicates parts available in assemblies only)	PART #	QTY
-	TRACK ROLLERS (LT10 SAWMILLS ON LT15 FRA	506701	1
1	BRACKET, ROLLER	506707-1	1
2	BEARING, 6305 2RS CX.	085706	2
3	PIERSCIEN OSADCZY SPR. 25Z PN-M/ 85111.	F81090-22	2
4	GUARD, TRACK ROLLER	501783-1	1
5	WASHER, 6.4 FLAT ZINC	F81053-1	2
6	WASHER, Z 6.1 SPLIT LOCK	F81053-3	2
7	BOLT, M6X12-8.8 HEX HEAD FULL THREAD ZIN	F81001-7	2
8	WASHER, 8.4 FLAT ZINC	F81054-1	10
9	NUT, M8-8-B HEX ZINC	F81032-1	4
10	BOLT, M8X110-8.8 FE/ZN5 PN-85/M-82105	F81002-145	1
11	BOLT, M8X16 -8.8-B HEX HEAD FULL THREAD	F81002-20	6
12	BRACKET, MAST GUIDE	503768-1	1
13	WASHER 8,2 SPLIT LOCK ZINC	F81054-4	2

6.4 Lower Sprocket Assembly

518175_001
518175_MANUAL

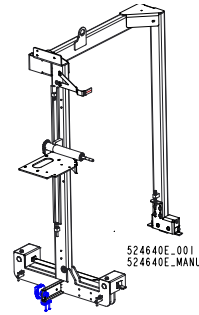
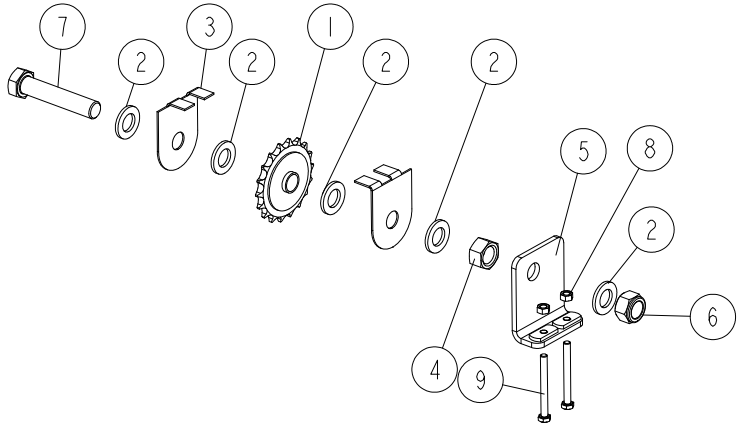

REF.	DESCRIPTION (◆ Indicates Parts Available In Assemblies Only)	PART #	QTY
-	SPROCKET ASSEMBLY, LOWER	518175	1
1	SPROCKET, #40 IDLER 17T 5/8ID	P04333	1
2	WASHER, 17 SPLIT LOCK ZINC	F81058-1	5
3	GUARD, CHAIN SPROCKET	092566-1	2
4	NUT, M16-8 HEX ZINC	F81036-1	1
5	TENSIONER, CHAIN	502524-1	1
6	NUT, M16-8 HEX NYLON ZINC LOCK	F81036-2	1
7	BOLT, M16X80-8.8 HEX HEAD FULL THREAD ZINC	F81006-11	1
8	NUT, M6-8 HEX ZINC	F81031-1	2
9	BOLT, M6X60-8.8 HEX HEAD FULL THREAD ZINC	F81001-9	2

6.5 Track Rail, Rollers & Travel Pins

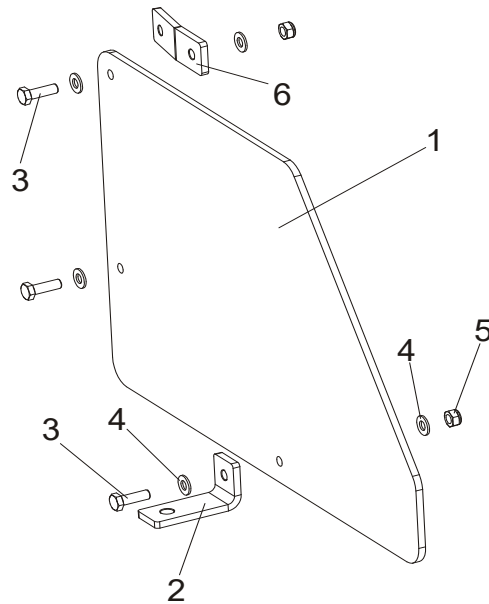

REF.	DESCRIPTION (◆ Indicates Parts Available In Assemblies Only)	PART #	QTY
	GUARD, LT15 COMPLETE LOWER	093858	1
1	PLATE, LT15 LOWER GUARD	093859	1
2	BRACKET, LOWER PTD	086172-1	1
3	BOLT, M8X25-8.8 HEX HEAD FULL THREAD	F81002-5	3
4	WASHER, 8.4 FLAT ZINC	F81054-1	6
5	NUT, M8-8-B HEX NYLON ZINC LOCK	F81032-2	3
6	BRACKET, SIDE	086171-1	2

6.6 Power Cord Bracket (Part No. 097449)

097449_001
097449_MANUAL

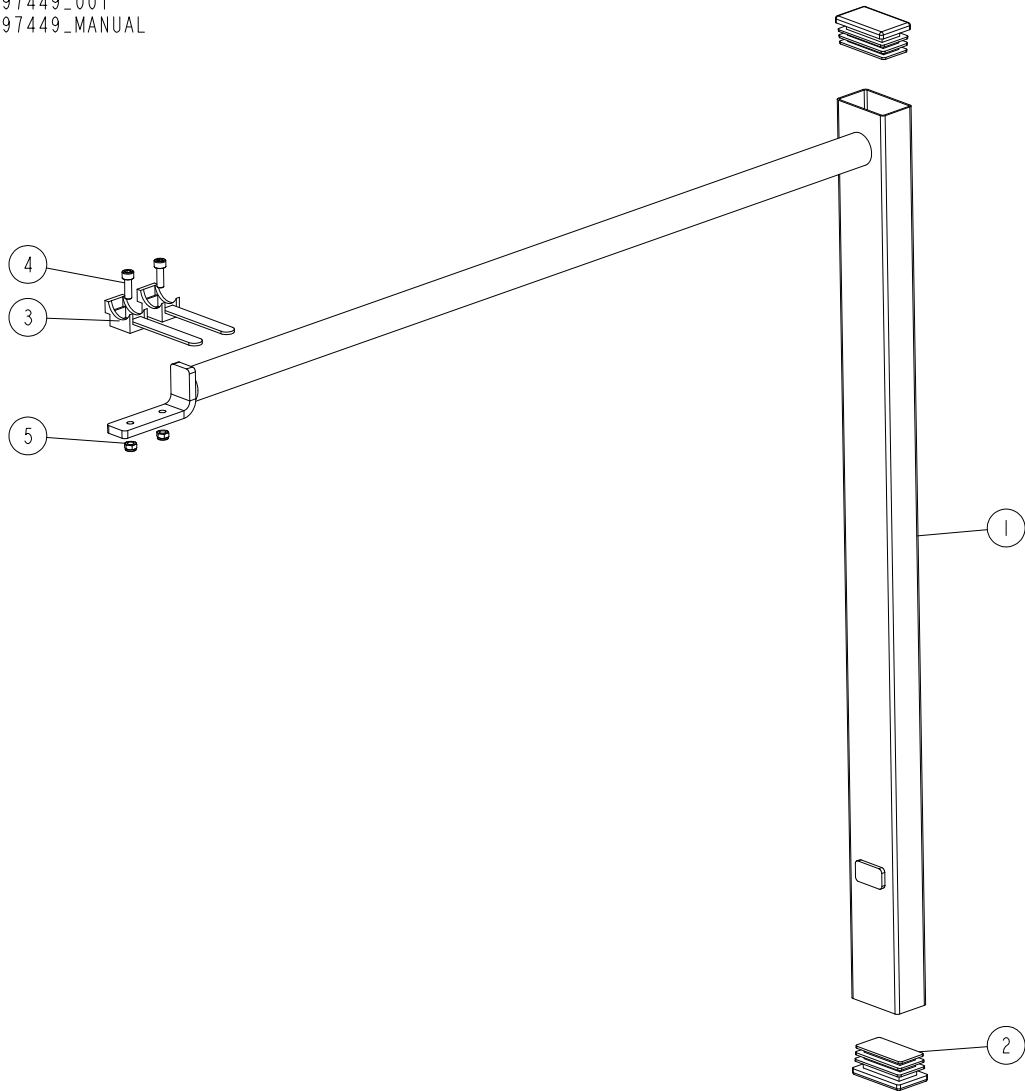

REF.	DESCRIPTION (◆ indicates parts available in assemblies only)	PART #	QTY	
	BRACKET, LT15 POWER CORD COMPLETE	097449	1	
1	BRACKET, LT15 POWER CORD PAINTED	086132-1	1	
2	CAP, 50X30 BLACK	095919	2	
3	HOLDER, UP30 CABLE PLASTIC TIE	F81082-1	2	
4	SCREW, M5X16-8.8 HEX SOCKET HEAD CAP ZINC	F81000-25	2	
5	NUT, M5-8-FE/ZN5 DIN985	F81030-2	2	

SECTION 7 UP/DOWN SYSTEM

7.1 Up/Down Crank Assembly

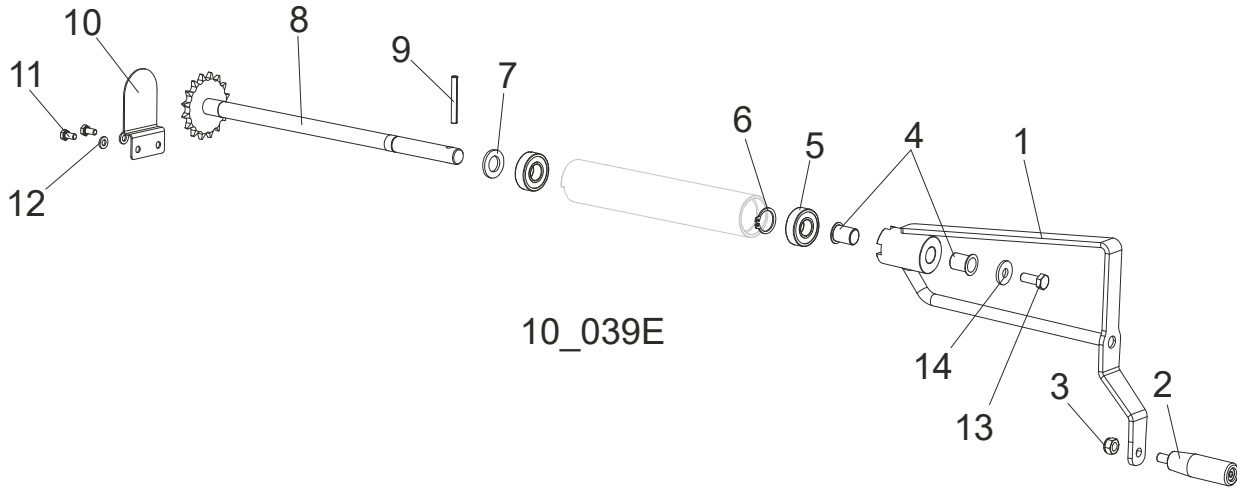

REF.	DESCRIPTION (◆ Indicates Parts Available In Assemblies Only)	PART #	QTY
	FEED CRANK ASSEMBLY, LT15/MP100	538948	1
1	CRANK WELDMENT, LT15	538949-1	1
2	KNOB, 12992M10 PLASTIC CRANK HANDLE	086338	1
3	NUT, M10-8-B HEX NYLON ZINC LOCK	F81033-1	1
4	BUSHING, GFM-1719-25	094142	2
5	BEARING, 6203-2RS	086114	2
6	RING, Z17 OUTSIDE RETAINING	F81090-21	1
7	WASHER, 17 FLAT ZINC	F81058-1	1
8	SHAFT, LT15 W/SPROCKET	097242-1	1
9	PIN, 6X50 ZINC ROLL	F81045-1	1
10	GUARD, UPPER LT15 SAW HEAD SPROCKET	092567	1
11	BOLT, M6X12-8.8 HEX HEAD FULL THREAD ZINC	F81001-7	2
12	WASHER, 6.4 FLAT ZINC	F81053-1	2
13	BOLT, M10-1.5X25MM HH GR8.8, BOLT, M10X25-8.8-FE/ZN5	F81003-11	1
14	WASHER, 10.5 ZINC FLAT SPECIAL	F81055-6	1

7.2 Operator's Bracket (Option)

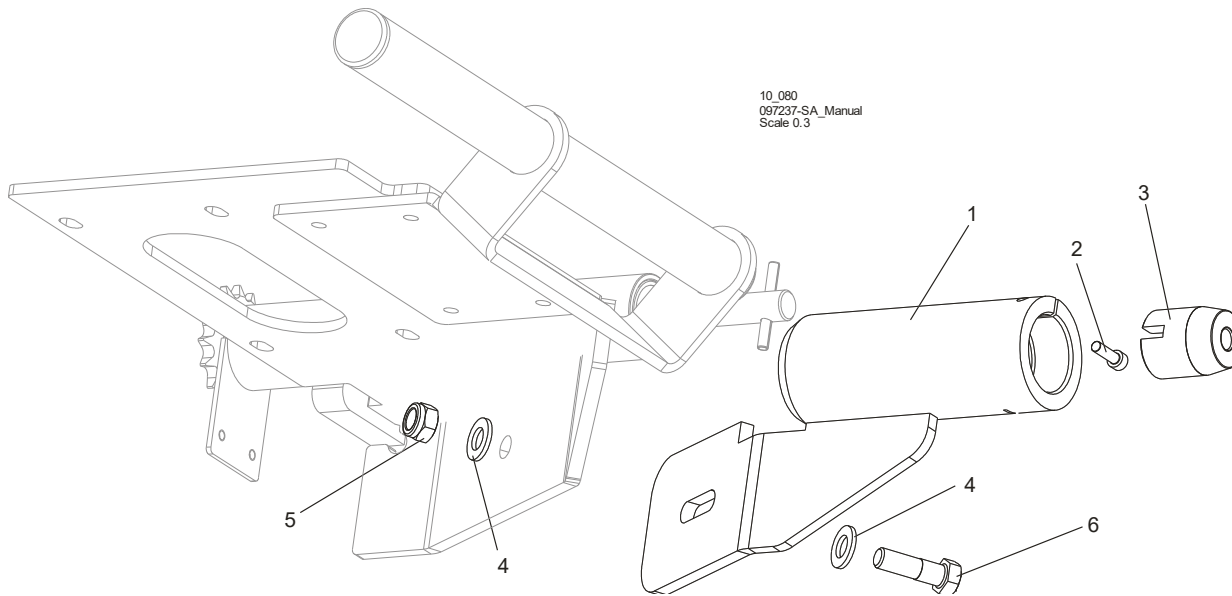

REF.	DESCRIPTION (◆ Indicates Parts Available In Assemblies Only)	PART #	QTY
	BRACKET, OPERATOR'S	512248	1
1	BRACKET, LT10	512241-1	1
2	SCREW, M6 X 20 8.8 HEX SOCKET HEAD CAP ZINC	F81001-22	1
3	BUSHING, DRIVING	512244	1
4	WASHER, 13 FLAT ZINC	F81056-1	2
5	NUT, M12-8 HEX NYLON ZINC LOCK	F81034-2	1
6	BOLT, M12X40-8.8 HEX HEAD ZINC	F81004-1	1

7.3 Up/Down Drive Sprocket Assembly

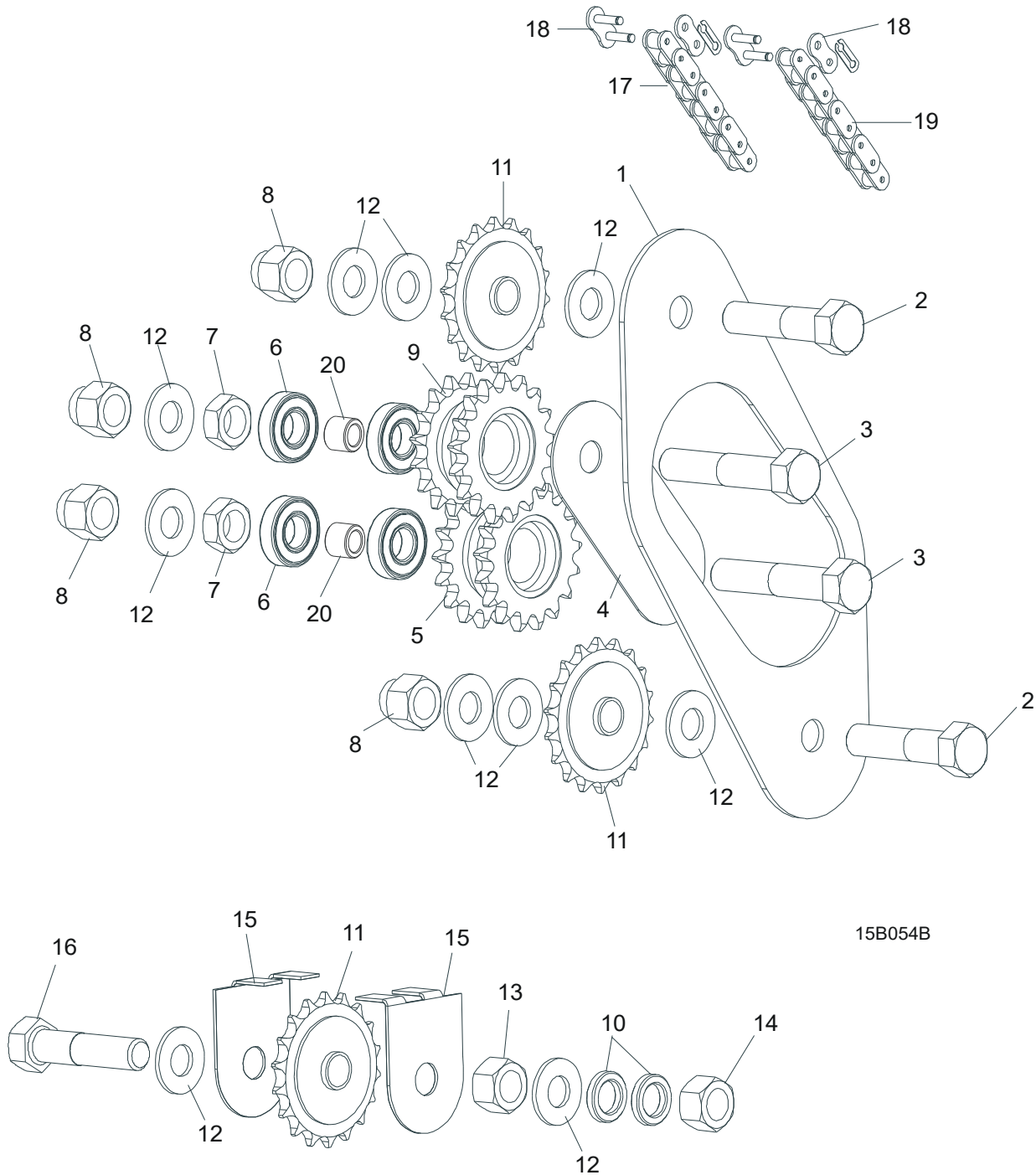

15B054B

REF.	DESCRIPTION (◆ Indicates Parts Available In Assemblies Only)	PART #	QTY
1	GUARD, LT15 UP/DOWN CHAIN INTERNAL	014907	1
2	BOLT, M16X65-8.8-B HEX HEAD FULL THREAD ZINC	F81006-1	2
3	BOLT, M16X80 8.8-B HEX HEAD FULL THREAD ZINC	F81006-11	2
4	PLATE, UP/DOWN DRIVE SPROCKET MOUNT	087104-1	1
5	SPROCKET, DUAL 17/17	086812-1	1
6	BEARING, R-10	P04156	4

7	NUT, M16 HEX THIN ZINC	F81036-4	2	
8	NUT, M16-8 HEX NYLON ZINC LOCK	F81036-2	4	
9	SPROCKET, 16/17 DUAL	086813-1	1	
10	WASHER, 41/64"X 1"X 3/16 SPACER	S12480	3	
11	SPROCKET, 17T G1#40-41 5/8" ID	P04333	3	
12	WASHER 17 FLAT ZINC	F81058-1	12	
13	NUT, M16-5.8 HEX ZINC	F81036-1	1	
14	NUT, M16-8 HEX NYLON ZINC LOCK	F81036-2	1	
15	GUARD,LT15 UP/DOWN CHAIN SPROCKET	092566-1	2	
16	BOLT, M16X75-8.8-B HEX HEAD FULL THREAD ZINC	F81006-10	1	
17	CHAIN, #40 X 111 1/2"	014831	1	
18	LINK, #40 MASTER	P04200	2	
19	CHAIN, #40 X 14 1/2"	P12496	1	
20	BUSHING, ZINC-PL.	095938-1	2	

7.4 Slide Pads

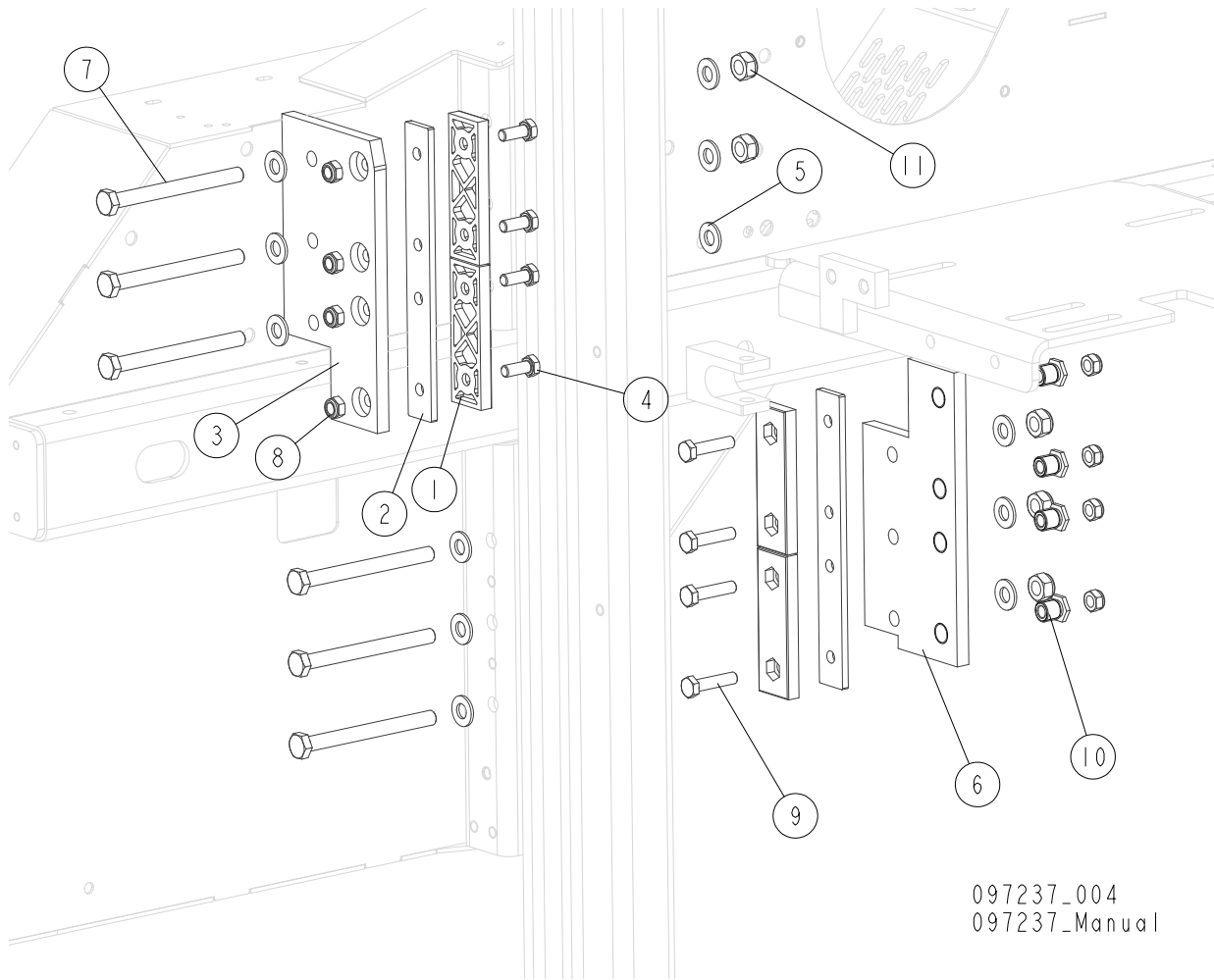

097237_004
097237_Manual

REF.	DESCRIPTION (* Indicates Parts Available In Assemblies Only)	PART #	QTY
1	PADS, DELRIN UP/DOWN SLIDE	M04096	4
2	PLATE, SLIDE PAD SPACER	094140-1	2
3	PLATE, GUIDE UPPER	094139-1	1
4	BOLT, M8X20-8.8-B HEX HEAD FULL THREAD ZINC	F81002-4	4
5	WASHER, 10.5 FLAT ZINC	F81055-1	12
6	PLATE, SLIDE PAD MOUNT	086682	1
7	BOLT, M10X110-8.8 HEX HEAD ZINC	F81003-43	6
8	NUT, M8-8-B HEX NYLON ZINC LOCK	F81032-2	8
9	BOLT, M8X35-8.8 HEX HEAD FULL THREAD ZINC	F81002-13	4
10	NUT, LT15 SLIDE PAD ADJUSTMENT ZINC-PLATED	086683	1
11	NUT, M10-8-B HEX NYLON ZINC LOCK	F81033-1	5

7.5 Mast Guide

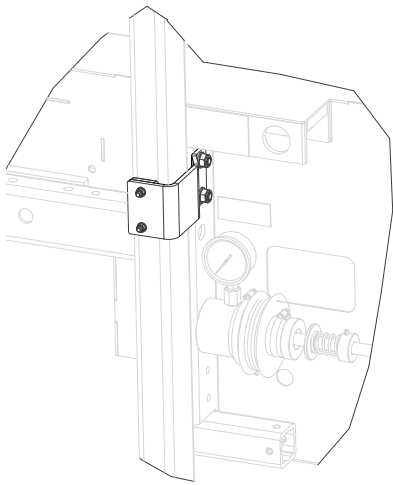

097237_002
097237_Manual

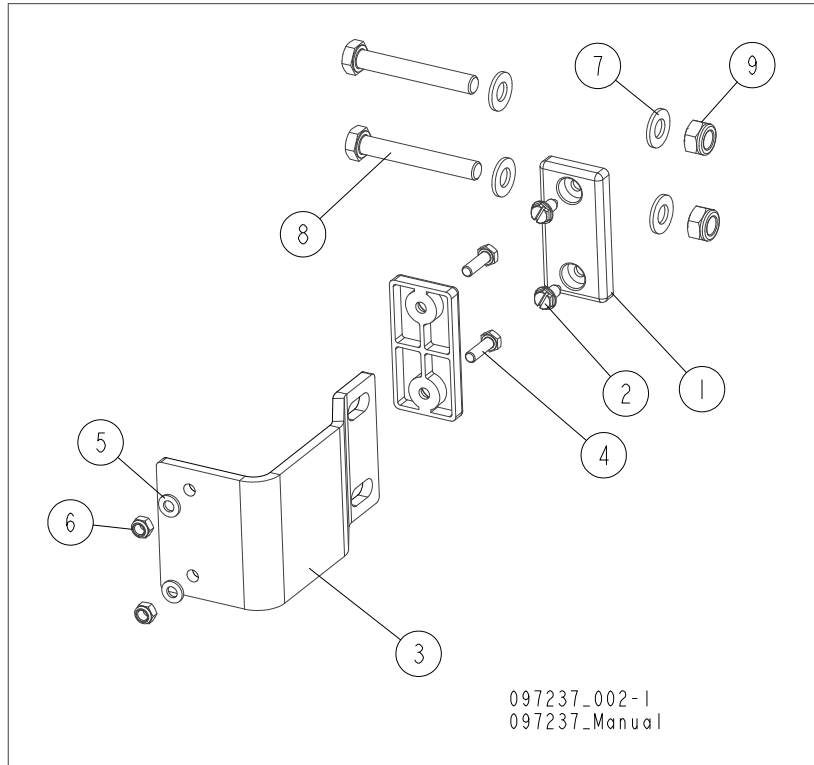

097237_002-1
097237_Manual

REF.	DESCRIPTION (* Indicates Parts Available In Assemblies Only)	PART #	QTY
1	PAD, CATAPILLAR TRACK	P13576	2
2	BOLT, 1/4-20 X 1/2 SELF-TAP HH	F05015-1	2
3	BRACKET, LT15 MAST GUIDE IDLE SIDE	087192-1	1
4	BOLT, M6X20-8.8 HEX HEAD FULL THREAD ZINC	F81001-2	2
5	WASHER, 6.4 FLAT ZINC	F81053-1	2
6	NUT, M6-8-B HEX NYLON ZINC LOCK	F81031-2	2
7	WASHER, 10.5 FLAT ZINC	F81055-1	4
8	BOLT, M10 X 70-8.8 HEX HEAD FULL THREAD ZINC	F81003-20	2
9	NUT, M10-8-B HEX NYLON ZINC LOCK	F81033-1	2

7.6 Blade Height Scale Assembly

538849_001
538849_MANUAL

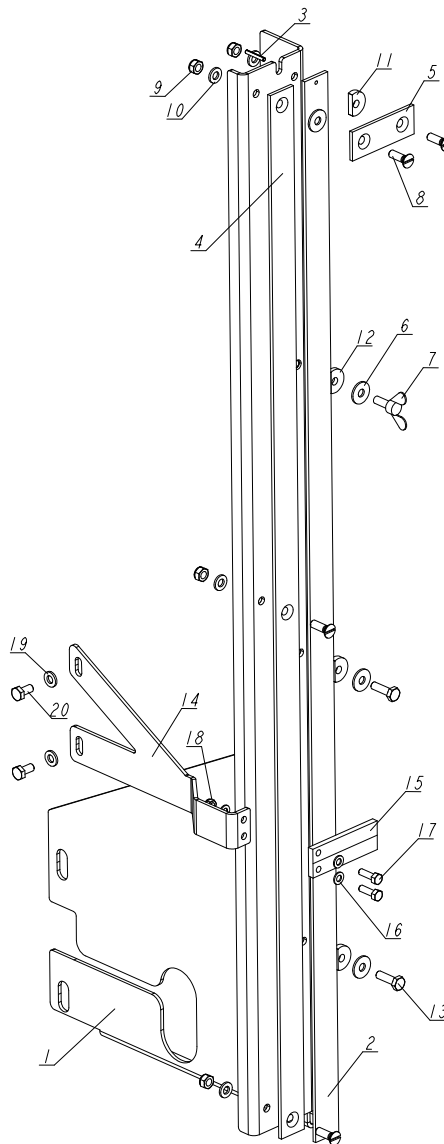

REF.	DESCRIPTION (* Indicates Parts Available In Assemblies Only)	PART #	QTY
-	SCALE ASSEMBLY, BLADE HEIGHT	538849	1
-	SCALE, METRIC BLADE HEIGHT - COMPLETE	095964	1
1	BRACKET, BLADE HEIGHT SCALE	095965-1	1
2	BAR, INCH SCALE	093133	1
3	PIN, 3X20 GEOMET ROLL	F81044-5	1
4	BAR, SCALE	092750	1
5	BAR, SCALE CLAMP	093134	1
6	WASHER, 6.5 SPECIAL FLAT ZINC	F81053-11	4
7	SCREW, M6X16 FE/ZN5 DIN-316/BN-276 THUMB	F81001-16	1

REF.	DESCRIPTION (* Indicates Parts Available In Assemblies Only)	PART #	QTY	
8	SCREW, M6X20-5.8-B SLOTTED COUNTERSUNK HEAD ZINC	F81001-31	4	
9	NUT, M6-8-B HEX NYLON ZINC LOCK	F81031-2	6	
10	WASHER, 6.4 FLAT ZINC	F81053-1	6	
11	WASHER, 6.2X20X4.5 SPECIAL	503098	3	
12	WASHER, 6.2X20X3.5 SPECIAL	503096	1	
13	BOLT, M6X20 8.8 HEX HEAD FULL THREAD ZINC	F81001-2	2	
-	INDICATOR, BLADE HEIGHT SCALE - COMPLETE (QUARTER INCH)	517064	1	
14	BRACKET, INDICATOR MOUNT	517063-1	1	
15	INDICATOR, BLADE HEIGHT SCALE	094821	1	
16	WASHER, 5.3 FLAT ZINC	F81052-1	4	
17	BOLT, M5X16 8.8 HEX HEAD FULL THREAD ZINC	F81000-20	2	
18	NUT, M5-8-FE/ZN5 DIN985	F81030-2	2	
19	WASHER, 6.4 FLAT ZINC	F81053-1	2	
20	BOLT, M6X12 8.8 HEX HEAD FULL THREAD ZINC	F81001-7	2	

7.7 Scale Mount Bracket Assembly

524635-G14_001
 524635-G14_MANUAL

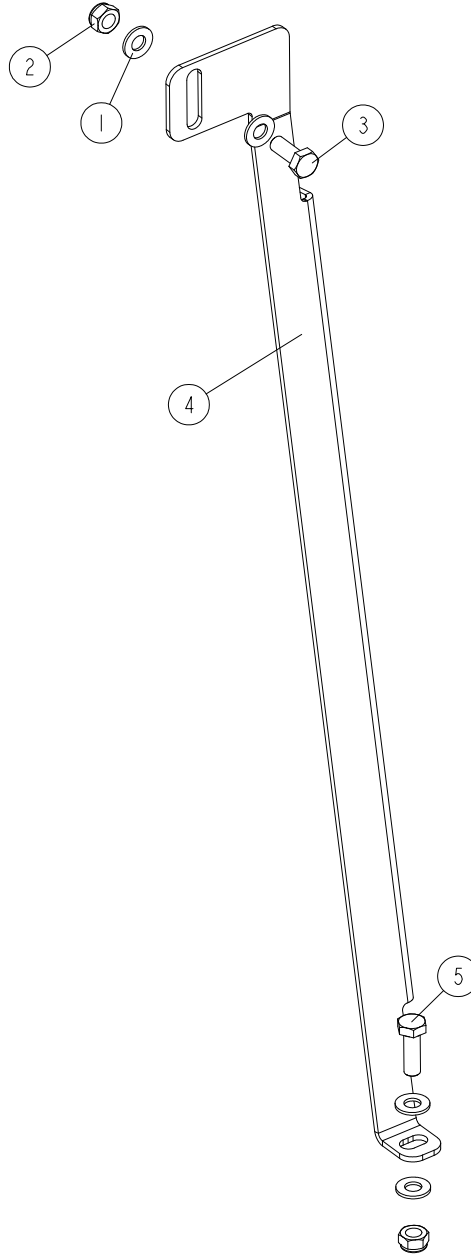

REF	DESCRIPTION (u indicates parts available in assemblies only)	PART #	QTY
1	WASHER, 8.4 FLAT ZINC	F81054-1	4
2	NUT, M8-8-B HEX NYLON ZINC LOCK	F81032-2	2
3	BOLT, M8X20-8.8-B HEX HEAD FULL THREAD ZINC	F81002-4	1
4	BRACKET, SCALE MOUNT.	095291-1	1
5	BOLT, M8X25-8.8-B HEX HEAD FULL THREAD	F81002-5	1

7.8 LT10 Electric Up/Down System (Option)

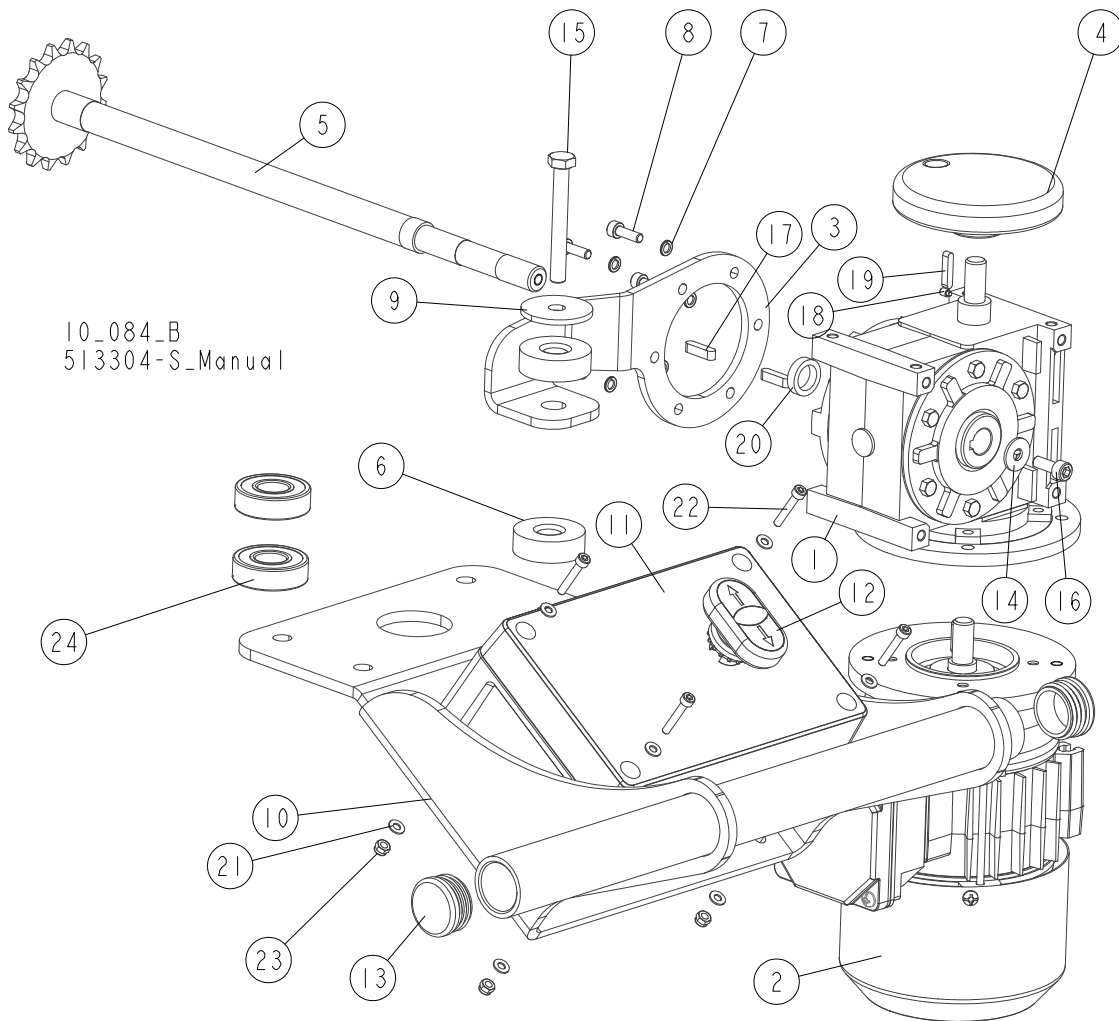

REF.	DESCRIPTION (* Indicates Parts Available In Assemblies Only)	PART #	QTY
	POWER FEED ASSEMBLY, LT10	513304-S	1
	LT10 UP/DOWN SYSTEM	513304	1
	MOTOREDUCER, MRA-03/16/0,18-1400-120/11	513288	1
1	GEARBOX, MRA-03/16/140/11-WBS/KM2/RR/B3	513537	1
2	MOTOR, 0.18-1400-120/11-B	513536	1
3	PLATE, TORQUE ARM	513083-1	1
4	KNOB	513305	1
5	SHAFT WITH SPROCKET	513307 ¹	1
6	WASHER, RUBBER	090443	2
7	WASHER, 5.1 SPLIT LOCK ZINC	F81052-2	6
8	SCREW, M5X16-8.8 HEX SOCKET HEAD CAP ZINC	F81000-25	6
9	WASHER, 5X9X38	513086	1
10	HANDLE WELDMENT, LT10	513302-1	1
11	BOX, LT10 UP/DOWN CONTROL	512942	1
12	BUTTON, M22-DD-S-X7/X7	090917	1

7

UP/DOWN SYSTEM*LT10 Electric Up/Down System (Option)*

REF.	DESCRIPTION (* Indicates Parts Available In Assemblies Only)	PART #	QTY	
13	CAP, BLACK TUBE END	517616	2	
14	WASHER, 6.5 SPECIAL FLAT ZINC	F81053-11	1	
15	BOLT, M8 X 65 8.8 HEX HEAD FULL THREAD ZINC	F81002-9	1	
16	SCREW, M6X16 HEX SOCKET HEAD CAP	F81001-21	1	
17	KEY, A5X5X20 PARALLEL	513320	2	
18	SCREW, M4x6 ISO4028 SET	F81014-6	1	
19	KEY, A4X4X20 PARALLEL	513321	1	
20	BUSHING, N14XN20X5 SPACER	513160	1	
21	WASHER 4.3 FLAT ZINC	F81051-2	8	
22	SCREW, M4x25 8.8 HEX SOCKET HEAD CAP ZINC	F81011-3	4	
23	NUT, M4-B HEX NYLON ZINC LOCK	F81029-1	4	
24	BEARING, 6203-2RS	086114 ¹	2	

¹ Belongs to 513304-S, not included in 513304.

7.9 Electric Up/Down Control Assembly (Option for CE Version)

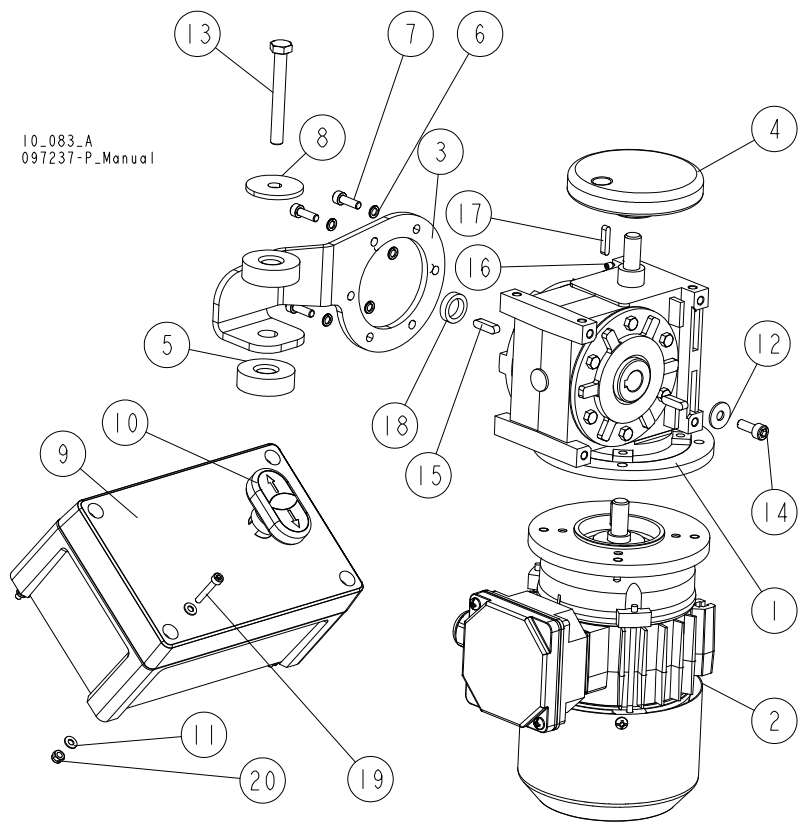

REF.	DESCRIPTION (◆ Indicates Parts Available In Assemblies Only)	PART #	QTY
	CONTROL ASSEMBLY, LT10 ELECTRIC UP/DOWN (CE VERSION)	514032	1
	MOTOREDUCER, MRA-03/16/[0.18-1400-120/11-WBS-B]/KM2/B3	513288	1
1	GEARBOX, MRA-03/16/140/11-WBS/KM2/RR/B3 WORM	513537	1
2	MOTOR, 0.18-1400-120/11-B	513536	1
3	ARM, TORQUE	513083-1	1
4	KNOB	513305	1
5	WASHER, RUBBER	090443	2
6	WASHER, 5.1 SPLIT LOCK ZINC	F81052-2	6
7	SCREW, M5X16-8.8 HEX SOCKET HEAD CAP ZINC	F81000-25	6
8	WASHER, 5X9X38	513086	1
9	BOX, LT10 COMPLETE ELECTRIC	512942	1
10	BUTTON, M22-DD-S-X7/X7	090917	1
11	WASHER, 4.3 FLAT ZINC	F81051-2	8
12	WASHER, 6.5 SPECIAL FLAT ZINC	F81053-11	1
13	BOLT, M8X65 8.8 HEX HEAD FULL THREAD ZINC	F81002-9	1
14	SCREW, M6x16 8.8 HEX SOCKET HEAD CAP ZINC	F81001-21	1
15	KEY, A5x5x20 PARALLEL	513320	2
16	SCREW, M4x6 ISO4028 SET	F81014-6	1
17	KEY, A4x4x20 PARALLEL	513321	1
18	BUSHING, 14/20-5	513160	1
19	SCREW, M4X25-8.8 HEX SOCKET HEAD CAP ZINC	F81011-3	4
20	NUT, M4-8 HEX NYLON ZINC LOCK	F81029-1	4

7.10 Limit Switch Activator Plate

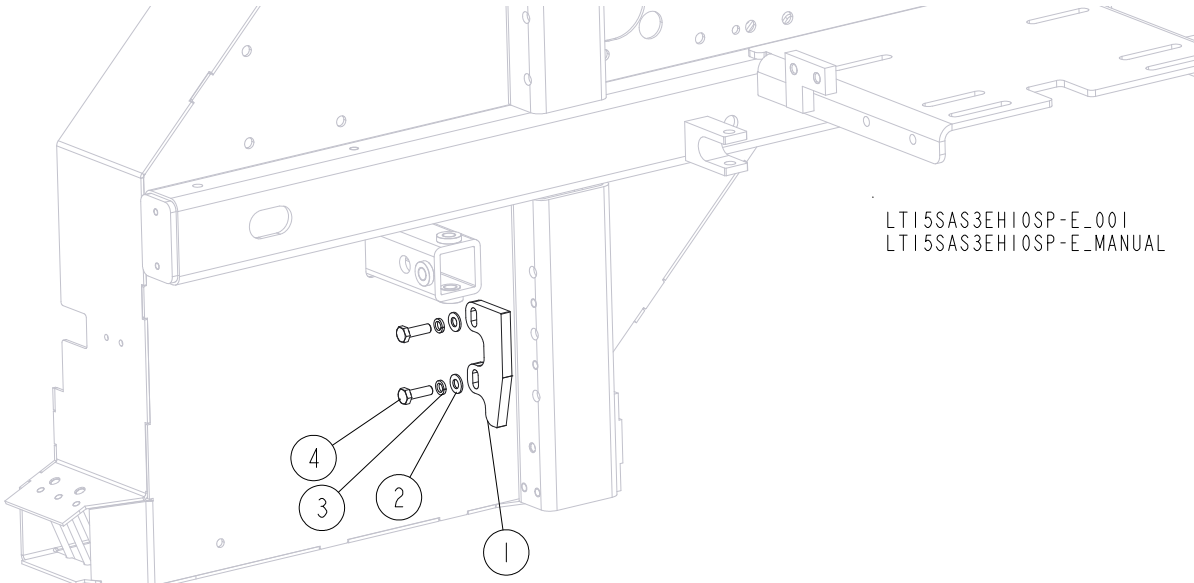

REF.	DESCRIPTION (◆ Indicates Parts Available In Assemblies Only)	PART #	QTY
-	PLATE, LIMIT SWITCH ACTIVATOR - COMPLETE	516510	1
1	PLATE, LIMIT SWITCH ACTIVATOR	516509-1	1
2	WASHER, 8.4 FLAT ZINC	F81054-1	2
3	WASHER, 8.2 SPLIT LOCK ZINC	F81054-4	2
4	BOLT, M8X25-8.8-B HEX HEAD FULL THREAD ZINC	F81002-5	2

SECTION 8 MOTOR KITS

8.1 Motor Kit, LT15SA EH15

509145-3_001
509145-3_MANUAL

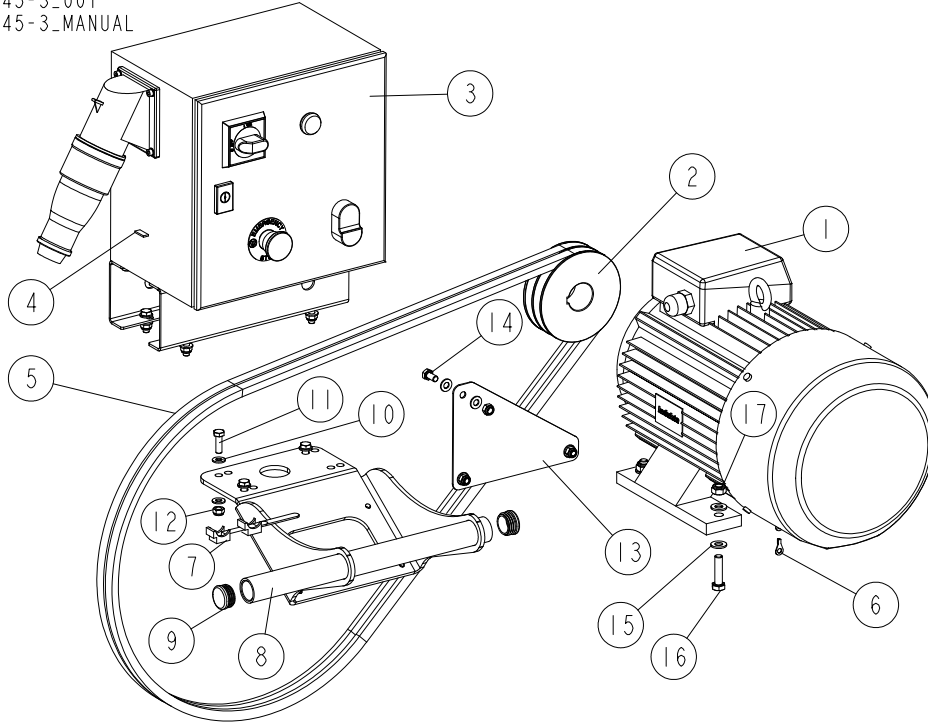

REF.	DESCRIPTION (* Indicates Parts Available in Assemblies Only)	PART #	QTY
-	MOTOR KIT, EH15 FOR LT15SA	509145-3	1
1	MOTOR, 11KW PSG 132M-2A	526677	1
2	PULLEY, E15 MOTOR 2-GROOVE	091560	1
3	ELECTRIC BOX, EH15 FOR LT15SA/ LT15WB See Section 8.3	509143	1
4	RIBBON, MK8 BLACK COLOUR	F81081-34	1
5	V-BELT, 2BX81	014819-2	1
6	TERMINAL, KO 2.5/6 RING	F81064-13	7
7	TIE, UP 30 UV WIRE	F81082-1	2
8	HANDLE WELDMENT, LT15SA	513302-1	1
9	CAP, 1530 TUBE END (HOLE 30)	517616	2
10	WASHER, 8.4 FLAT ZINC	F81054-1	13
11	BOLT, M8X25-8.8-B HEX HEAD FULL THREAD ZINC	F81002-5	3
12	NUT, M8-8-B HEX NYLON ZINC LOCK	F81032-2	7
13	PLATE, COVER	094247-1	1
14	BOLT, M8X16-8.8-B HEX HEAD FULL THREAD ZINC	F81002-20	3
15	WASHER, 10.5 FLAT ZINC	F81055-1	8
16	BOLT, M10X40-8.8 HEX HEAD FULL THREAD ZINC	F81003-16	4
17	NUT, M10-8-B HEX NYLON ZINC LOCK	F81033-1	4

8.2 Motor Kit, LT15SA EH7S/EH10S

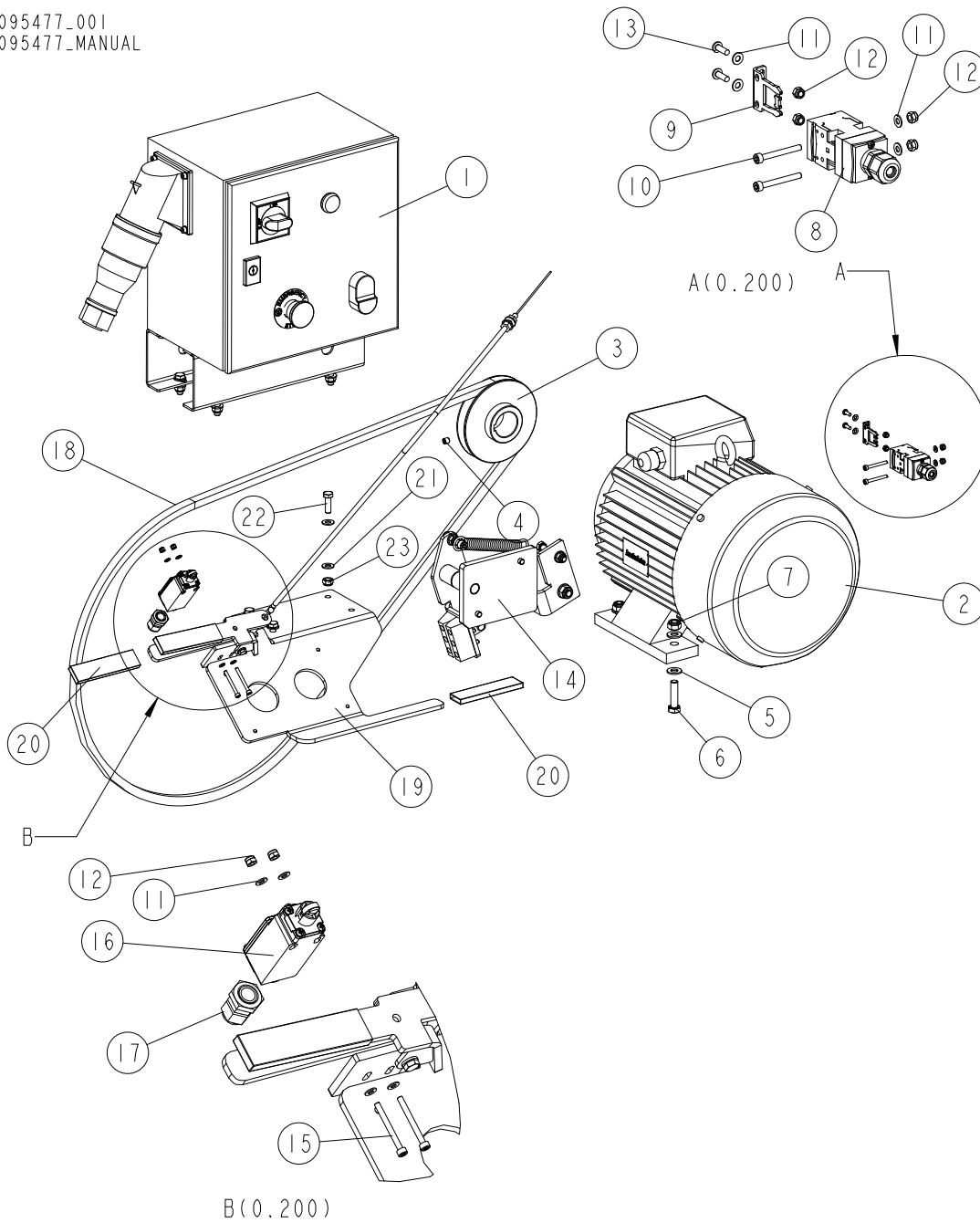
 095477_001
 095477_MANUAL

REF.	DESCRIPTION (* Indicates Parts Available in Assemblies Only)	PART #	QTY
-	MOTOR KIT, EH7S FOR LT15SA	095477	1
-	MOTOR KIT, EH10S FOR LT15SA	506242	1
1	ELECTRIC BOX, EH7 FOR LT15SA See Section 8.3	096001-M	1
	ELECTRIC BOX, EH10 FOR LT15SA See Section 8.3	506235	1
2	MOTOR, 5.5KW SG 132S-2A	526139	1
	MOTOR, 7.5KW SG 132S-2B	526141	1
3	PULLEY, E10 MOTOR	086807-1	1
4	SCREW, M8X8-33H GEOMET HEX SOCKET SET W/FLAT POINT	F81014-1	1

REF.	DESCRIPTION (* Indicates Parts Available in Assemblies Only)	PART #	QTY	
5	WASHER, 10.5 FLAT ZINC	F81055-1	8	
6	BOLT, M10X40-8.8 HEX HEAD FULL THREAD ZINC	F81003-16	4	
7	NUT, M10-8-B HEX NYLON ZINC LOCK	F81033-1	4	
8	SWITCH, AZ17-11ZRK SAFETY	094232	1	
9	KEY, AZ 17/170-B5 SAFETY SWITCH	094422	1	
10	SCREW, M4X35 8.8 HEX SOCKET HEAD CAP ZINC	F81011-34	2	
11	WASHER, 4.3 FLAT ZINC	F81051-2	8	
12	NUT, M4-8 HEX NYLON ZINC LOCK	F81029-1	6	
13	SCREW, M4X12-5.8-B CROSS RECESSED PAN HEAD ZINC	F81011-43	2	
14	BRAKE ASSEMBLY, EH7S/10S/15S FOR LT15SA See Section 8.4	527676	1	
15	SCREW, M4X40 8.8 HEX SOCKET HEAD CAP ZINC	F81011-37	2	
16	SWITCH, FA134 Z11 SAFETY	100910	1	
17	GLAND, DP9/H CABLE	F81096-2	1	
18	V-BELT, BX81	014819	1	
19	GRIP WELDMENT, LT15SA	514128-1	1	
20	COVER, RRWA-91626-110 GRIP	086875	2	
21	WASHER, 8.4 FLAT ZINC	F81054-1	7	
22	BOLT, M8X25-8.8-B HEX HEAD FULL THREAD ZINC	F81002-5	3	
23	NUT, M8-8-B HEX NYLON ZINC LOCK	F81032-2	4	

8.3 EH7/EH10/EH15 Electrical Box

096001-M_002
096001-M_MANUAL

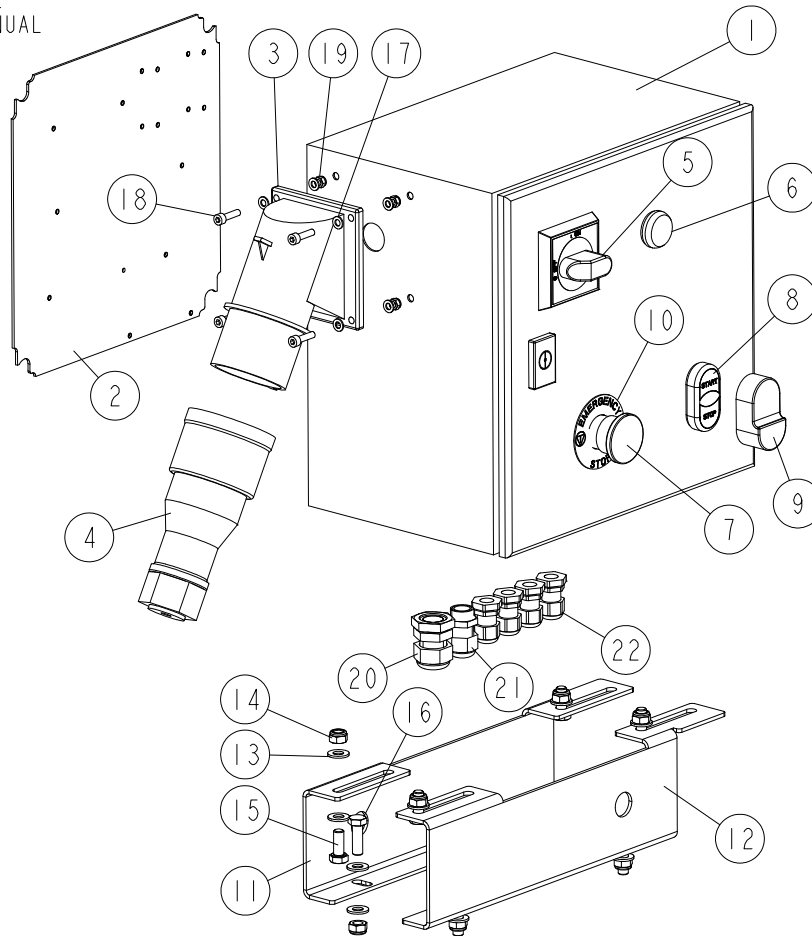

REF.	DESCRIPTION (* Indicates Parts Available in Assemblies Only)	PART #	QTY
-	ELECTRICAL BOX, EH7 FOR LT15SA	096001-M	1
1	BOX, LT15SA ELECTRICAL	527678	1
2	PLATE, ELECTRICAL BOX MOUNT	507750	1
3	PLUG, 16A 5P 778152-6 PCE	E85239	1
4	SOCKET, 16A 5P 2152-6TT PCE	E85240	1
5	HANDLE, OHB2AJ ABB SELECTOR	088265-1	1
6	LIGHT, M22 LED 24V BLUE CONTROL	090448	1
7	BUTTON, XB4 BS542 EMERGENCY STOP	086556	1
8	SWITCH, 24V MOELLER ILLUMINATED START/STOP	090452	1
9	DIAPHRAGM, M22-T-DD MOELLER	090462	1
10	WASHER, E-STOP BUTTON	086561	1
11	FOOT, ELECTRICAL BOX	550964-1	1
12	FOOT, ELECTRICAL BOX	550965-1	1
13	WASHER, 8.4 FLAT ZINC	F81054-1	16
14	NUT, M8-8-B HEX NYLON ZINC LOCK	F81032-2	8
15	BOLT, M8X20 8.8 HEX HEAD FULL THREAD ZINC	F81002-4	4
16	BOLT, M8X25-8.8-B HEX HEAD FULL THREAD ZINC	F81002-5	4
17	WASHER, 5.3 FLAT ZINC	F81052-1	8
18	SCREW, M5X20 8.8 HEX SOCKET HEAD CAP ZINC	F81000-72	4

REF.	DESCRIPTION (* Indicates Parts Available in Assemblies Only)	PART #	QTY	
19	NUT, M5-8 DIN985 HEX NYLON ZINC LOCK	F81030-2	4	
20	GLAND, DP16/H CABLE	F81096-7	1	
21	GLAND, DW11/H CABLE	085388	1	
22	GLAND, DP 9/H CABLE	F81096-2	4	

8.4 Motor Brake Assembly

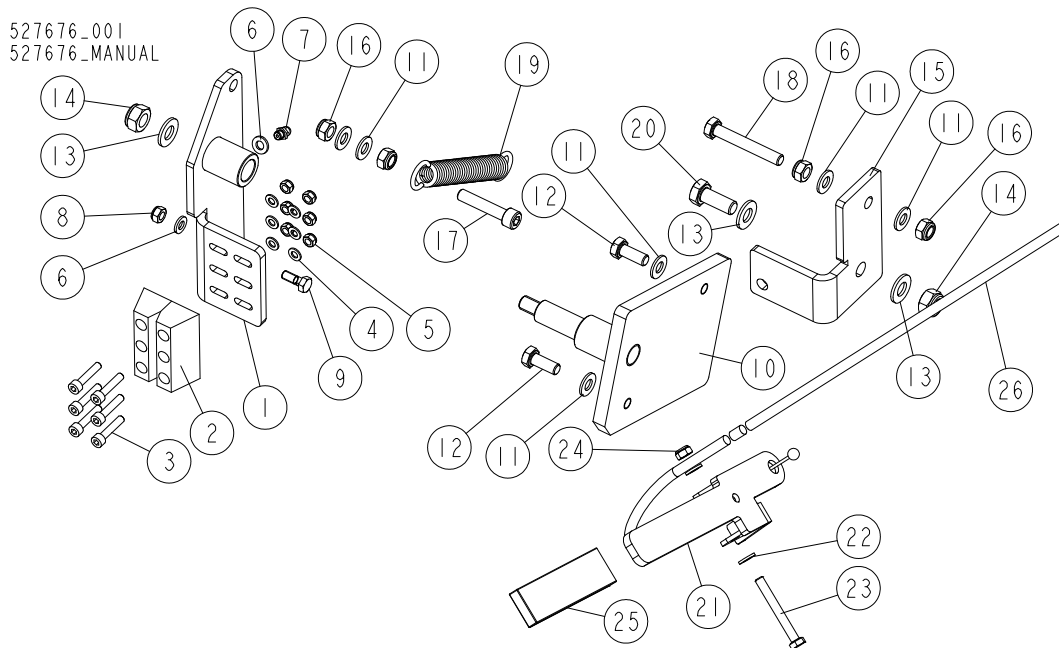

REF.	DESCRIPTION (* Indicates Parts Available in Assemblies Only)	PART #	QTY
-	BRAKE ASSEMBLY, EH7S/10S/15S LT15SA MOTOR	527676	1
-	BRAKE, LT15SA BLADE - COMPLETE	097367	1
1	ARM WELDMENT, BRAKE	097366-1	1
2	BLOCK, TENSIONER BRAKE	092111	2
3	SCREW, M5X25 8.8 HEX SOCKET HEAD CAP ZINC	F81000-7	6
4	WASHER, 5.3 FLAT ZINC	F81052-1	6
5	NUT, M5-8 DIN985 HEX NYLON ZINC LOCK	F81030-2	6
6	WASHER, 6.4 FLAT ZINC	F81053-1	2
7	FITTING, M6 GREASE (PN/M-86002)	086280	1
8	NUT, M6-8-B HEX NYLON ZINC LOCK	F81031-2	1
9	BOLT, THROTTLE CABLE CLAMP ZINC-PLATED	088120-1	1
10	PLATE WELDMENT, MOTOR BRAKE	097363-1	1
11	WASHER, 8.4 FLAT ZINC	F81054-1	6
12	BOLT, M8X20 8.8 HEX HEAD FULL THREAD ZINC	F81002-4	2
13	WASHER, 10.5 FLAT ZINC	F81055-1	3
14	NUT, M10-8-B HEX NYLON ZINC LOCK	F81033-1	2
15	BRACKET, CABLE	097368-1	1
16	NUT, M8-8-B HEX NYLON ZINC LOCK	F81032-2	4
17	SCREW, M8X40-8.8 HEX SOCKET HEAD CAP ZINC	F81002-29	1
18	BOLT, M8X55-8.8 HEX HEAD ZINC	F81002-8	1
19	SPRING, N1.9XN14.2X104	091865	1
20	BOLT, M10X25 8.8 HEX HEAD FULL THREAD	F81003-31	1
21	HANDLE WELDMENT, BLADE ENGAGEMENT	097221-1	1
22	WASHER, 6.4 FLAT ZINC	F81053-1	2
23	BOLT, M6X50-8.8 HEX HEAD ZINC	F81001-62	1
24	NUT, M6-8-B HEX NYLON ZINC LOCK	F81031-2	1
25	COVER, RRWA-91626-110 GRIP	086875	1
26	CABLE, WOOD MIZER 089450 KOD WM08.(LINMOT)	089450	1